

Empirical test of reinforcement sensitivity theory

Krupić, Dino

Doctoral thesis / Disertacija

2017

Degree Grantor / Ustanova koja je dodijelila akademski / stručni stupanj: **University of Rijeka, Faculty of Humanities and Social Sciences / Sveučilište u Rijeci, Filozofski fakultet u Rijeci**

Permanent link / Trajna poveznica: <https://um.nsk.hr/um:nbn:hr:186:845548>

Rights / Prava: [In copyright](#)/[Zaštićeno autorskim pravom.](#)

Download date / Datum preuzimanja: **2025-02-17**



Repository / Repozitorij:

[Repository of the University of Rijeka, Faculty of Humanities and Social Sciences - FHSSRI Repository](#)



UNIVERSITY OF RIJEKA
POSTGRADUATE DOCTORAL STUDY OF
PSYCHOLOGY

Dino Krupić

**Empirical test of Reinforcement
Sensitivity Theory**

DOCTORAL THESIS

Rijeka, 2017

This page is intentionally left blank

This page is intentionally left blank

UNIVERSITY OF RIJEKA
POSTGRADUATE DOCTORAL STUDY OF
PSYCHOLOGY

Dino Krupić

**Empirical test of Reinforcement
Sensitivity Theory**

DOCTORAL THESIS

Rijeka, 2017

SVEUČILIŠTE U RIJECI
SVEUČILIŠNI POSLIJEDIPLOMSKI ZNANSTVENI
DOKTORSKI STUDIJ PSIHOLOGIJE

Dino Krupić

**Empirijska provjera teorije osjetljivosti
na potkrepljenje**

DOKTORSKI RAD

Mentor: dr.sc. Asmir Gračanin

Rijeka, 2017

MENTOR RADA: dr.sc. Asmir Gračanin, Filozofski fakultet u Rijeci, Odsjek za psihologiju

Doktorski rad obranjen je dana 22.09.2017. na Poslijediplomskom sveučilišnom (doktorskom) studiju psihologije na Filozofskom fakultetu u Rijeci pred povjerenstvom u sastavu:

- 1. prof.dr.sc. Igor Kardum, Filozofski fakultet u Rijeci, Odsjek za psihologiju**
- 2. prof.dr.sc. Denis Bratko, Filozofski fakultet u Zagrebu, Odsjek za psihologiju**
- 3. prof.dr.sc. Vladimir Takšić, Filozofski fakultet u Rijeci, Odsjek za psihologiju**

ACKNOWLEDGMENT

I am very fortunate to have so many beautiful people around me and this doctoral dissertation would not be complete without mentioning their contribution.

This dissertation could not have been done without the support of my lovely wife Dajana and her intellectual stimulation in the form of asking the question "So what *exactly* do you want to say with the thesis?", while my kids Nora and Oliver (in many ways) made me much more focused and organised.

Although there are many "significant others" that had important roles in finalizing the dissertation, I will mention here just a few. First, without my professor Igor Kardum I would not have been interested in personality psychology, whereas without my colleague Valerija Križanić I would probably not have chosen to have a scientific career. Second, I am very grateful to my mentor Asmir Gračanin for the patience, support and time invested in preparing this dissertation. A special thanks goes to Philip J. Corr who had a huge impact in shaping my scientific interest. Finally, I am grateful to my dear friends Stipe, Davor, Ben, Bero, Škic, Šteka and Vladimir among many others for the pleasant companionship and many intellectual discussions that shaped my thinking about psychology beyond scientific books and articles.

ABSTRACT

The relation between brain and personality is still undefined, and it seems that this topic has a long future in psychological research. This doctoral thesis focuses on the neuropsychological theory of personality – Reinforcement Sensitivity Theory (RST). It recognises three main dimensions; Behavioural Approach System (BAS), Behavioural Inhibition System (BIS) and Fight/Flight/Freezing System (FFFS). There are currently several competing questionnaires designed to measure these constructs. These questionnaires are frequently used interchangeably without evidence to what extent they converge. Thus the aim of this thesis is to examine whether the results of RST studies conducted with different RST-based questionnaires are comparable. The objective is to provide the theoretical framework to interpret results from RST studies conducted with different questionnaires and to provide suggestions for further development of RST and its psychometric instruments. Six studies were conducted to test convergent and predictive validity of RST questionnaires. The results showed that RST questionnaires should not be used interchangeably since: (a) they do not converge; (b) their BIS and FFFS scales do not predict defensive behaviour in the same way; (c) they do not predict emotional and motivational outcomes after performance feedback in the same way; (d) constructs measured by different BAS scales do not serve the same evolutionary function. The dissertation acknowledges the existence of four types of the BAS scales and provides the theoretical framework to reinterpret earlier findings from RST studies conducted with different questionnaires. The BIS scales converged highly with only one exception, while the FFFS scales converge, but show significant weaknesses in examining the theory.

Key words: personality, questionnaires, neuropsychology, psychometrics, Reinforcement Sensitivity Theory, BAS, BIS, FFFS

PROŠIRENI SAŽETAK

Prema neuropsihologijskoj teoriji ličnosti – Teoriji Osjetljivosti na Potkrepljenja (TOP) postoje tri temeljne dimenzije ličnosti koje su rezultat varijacija u aktivaciji tri zasebna neuralna kruga u mozgu; Bihevioralni Aktivacijski Sustav (BAS) koji se nalazi u sklopu dopaminergičkog sustava u mozgu koji je zadužen za sva ponašanja pristupanja okolini s ciljem pribavljanja resursa potrebnih za preživljavanje i reprodukciju; Sustav Borbe/Bijega/Blokiranja (BBBS) koji je povezan s aktivacijom limbičkog sustava i moždanog debla, a predstavlja mehanizam obrambenih ponašanja važnih za preživljavanje; te Bihevioralni Inhibicijski Sustav (BIS) koji se veže uz aktivaciju septohipokampalnog kruga koji generira stanje anksioznosti u situacijama podjednake aktivacije BAS i BBBS. Cilj anksioznosti je stvoriti nelagodno afektivno stanje kojim bi se potaknulo brže donošenje odluke, tj. razrješenje konflikta kao posljedica istovremene aktivacije BAS-a i BBBS-a.

Ove dimenzije ličnosti se mjere putem upitnika, tj. samoprocjena. Trenutno postoji više upitnika koji se koriste za mjerenje dimenzija TOP. Problem je što se rezultati različitih upitnika interpretiraju pod pretpostavkom da se međusobno ne razlikuju. Međutim, ranije provedena istraživanja upućuju na sustavne razlike među njima. Trenutno ne postoje radovi koji ispituju razinu podudarnosti upitnika TOP, što priječi daljnji razvoj ove teorije. Glavni istraživački problemi koji se razmatraju u sklopu ove disertacije su; (a) ispitati mjere li postojeći upitnici TOP konstrukte na jednak način, te shodno tomu; (b) ispitati opravdanost generalizacije zaključaka ranije provedenih istraživanja u kojima su se koristili različiti upitnici i (c) koliko je svaki od tih upitnika u skladu s teorijskim pretpostavkama.

Kako bi se odgovorilo na postavljene probleme, provedeno je šest istraživanja kojima su se testirale četiri hipoteze. U sklopu disertacije nalaze se istraživanja koja uključuju eksperimentalnu manipulaciju s ciljem izazivanja reakcija, te zatim ispitivanja povezanosti osobina ličnosti s intenzitetom izazvanih emocionalnih i motivacijskih reakcija, kao i klasična korelacijska istraživanja koja se baziraju na usporedbi upitnika TOP s drugim upitnicima. Rezultati su se analizirali nizom različitih oblika regresijskih, te konfirmatornih faktorskih analiza i strukturalnog modeliranja.

Prva hipoteza ove disertacije glasi da upitnici ne mjere dimenzije TOP-a na jednak način, zbog čega je ispitana konvergentna i divergentna valjanost pet najkorištenijih upitnika TOP. Na uzorku od 821 ispitanika konfirmatorna faktorska analiza je pokazala da; (a) se upitnici razlikuju u operacionalizaciji BAS skale što je rezultiralo s detektiranjem četiri različite operacionalizacije BAS-a; (b) operacionalizacija skale Borbe ne odgovara teorijskim

pretpostavkama; (c) BIS i BBBS skale konvergiraju u većem stupnju. Generalno, rezultati govore u prilog prvoj hipotezi. Drugom hipotezom se pretpostavilo kako će različiti upitnici TOP različito predviđati obrambene reakcije u prijetećim situacijama. Na uzorku od 1082 ispitanika korišteno je četiri upitnika TOP i samoprocjena obrambenih ponašanja. Rezultati regresijske analize ukazuju na podudarnost triju upitnika TOP, dok jedan značajno odstupa. Time je i druga hipoteza podržana. Konkretnije, upitnici TOP-a u većoj mjeri sukladni u operacionalizaciji skala BIS i BBBS u usporedbi sa skalama BAS-a. U sklopu treće hipoteze, pretpostavilo se da će se različiti upitnici TOP razlikovati u predviđanju emocionalnih reakcija u kontekstu obrazovanja. U kvazi-eksperimentalnom istraživanju u sedam zavisnih mjerenja na uzorku od 91 studentice psihologije u stvarnom akademskom kontekstu, BAS skale su bile različito povezane s pozitivnim i negativnim afektima uslijed dobivene dobre ili loše ocijene. Ista hipoteza testirana je i četvrtoj studiji na uzorku od 94 studentice, u kojoj se pokazalo da pojedinci koji postižu visoke rezultate na različitim skalama BAS-a reagiraju drugačije u situacijama kada dožive uspjeh i neuspjeh. I ovi rezultati jasno govore u prilog trećoj hipotezi. Posljednja hipoteza se također testirala u dvije odvojene studije, a glasila je da različite komponente BAS-a predstavljaju različite evoluirane mehanizme pribavljanja resursa, te da koreliraju s različitim oblicima životnog stila prema evolucijskoj teoriji osobne povijesti, što su rezultati u obje studije i potvrdili.

Rezultati testiranja sve četiri hipoteze jasno ukazuju na velike razlike između upitnika TOP u operacionalizaciji dimenzija. Opći zaključci ove disertacije jesu; (a) da postoje četiri operacionalizacije BAS-a i da svaka od njih objašnjava drugi aspekt motivacije približavanja; (b) da se BAS ne bi trebao smatrati jednodimenzionalnim konstruktom; (c) da se rezultati BIS-a i BBBS-a mogu lakše uspoređivati, tj. rezultati se lakše mogu generalizirati; (d) BBBS se ne može smatrati jednodimenzionalnim konstruktom, budući da subskale u sklopu ove dimenzije međusobno ne koreliraju. Pritom, treba naglasiti kako se veća odstupanja odnose na skale BAS-a, što uvelike doprinosi nekonzistentnim nalazima u radovima koji koriste različite upitnike TOP. Na temelju rezultata istraživanja u kojima se uspoređivala prediktivna valjanost BAS-a, ponuđen je teorijski okvir za interpretaciju rezultata dobivenih upotrebom različitih upitnika TOP. Cilj tog okvira jest doprinijeti preciznijem definiranju hipoteza u sklopu TOP, što bi doprinijelo većoj provjerljivosti teorije, te omogućilo njen daljnji razvoj. Konačno, razmatraju se i konkretne sugestije za daljnji razvoj upitnika ove teorije.

Ključne riječi: ličnost, upitnici, neuropsihologija, psihometrija, teorija osjetljivosti na potkrepljenja, BAS, BIS, FFFS

CONTENTS

ACKNOWLEDGMENT	III
ABSTRACT	IV
PROŠIRENI SAŽETAK	V
CONTENTS	VII
1. INTRODUCTION	1
1.1. Personality	2
1.2. Historical and philosophical background of RST	2
1.2.1. Original reinforcement sensitivity theory (o-RST)	5
1.3. Revised RST (r-RST)	6
1.3.1. Redefinition of the RST dimensions	6
1.3.2. Relations of the BAS with BIS and FFFS	9
1.3.3. Psychometric operationalisation of the r-RST dimensions	10
1.3.3.1. Undefined standard measure of RST traits	10
1.3.3.2. Brief review of the current RST questionnaires	10
1.3.3.3. r-RST questionnaires	11
1.3.3.4. Review of the current findings on differences between RST questionnaires	12
1.4. Research question, hypotheses and objective	13
2. ELABORATION	17
2.1. Content of approach motivation scales	18
2.2. Content of avoidance motivation scales	20
2.2.1. Summary	22
2.3. Review of the conducted studies	23
2.3.1. Construct and convergent validity of RST questionnaires	23
2.3.2. Predicting defensive behaviours	28
2.3.3. Predicting emotional states and motivational outcomes in real life settings ..	30
2.3.4. Predicting motivation and self-efficacy after positive and negative feedback in experimental settings	31
2.3.5. BAS scales predicting evolved individual differences in motivation	32
2.4. Integration of findings and new directions in the theory	34

2.4.1. The multidimensional BAS.....	36
2.4.1.1. <i>Wanting</i> – extrinsic motivation.....	37
2.4.1.2. Incentive motivation.....	38
2.4.1.3. Striving	39
2.4.1.4. Liking.....	39
2.4.1.5. Dynamic model of the BAS.....	40
2.4.1.6. The BAS components and neurotransmitters and hormones	42
2.4.1.7. Interaction between BAS components.....	44
2.4.2. The BIS as an emotional rather than cognitive construct	45
2.4.3. The FFFS – panic, not behaviour	46
2.4.4. Interaction between RST systems	47
2.5. Suggestions for the further development of RST	48
3. CONCLUSION.....	51
4. REFERENCES	57
5. LIST OF TABLES	71
6. LIST OF FIGURES	73
7. APPENDIX	75
7.1. Five reinforcement sensitivity theory (RST) of personality questionnaires: Comparison, validity and generalization	77
7.2. Personality and defensive behaviour: A factor analytic approach to threat scenario choices	95
7.3. Individual differences in emotion elicitation in university examinations: A quasi- experimental study	114
7.4. High BAS and low BIS in overconfidence, and their impact on motivation and self-efficacy after positive and negative performance.....	131
7.5. The evolution of the Behavioural Approach System (BAS): Cooperative and competitive resource acquisition strategies.....	150
7.6. Slow and fast BAS: Interpretation of the behavioural approach system (BAS) within Life History Theory	167



Introduction

1. INTRODUCTION

1.1. Personality

Personality can be understood as aggregated measures of behaviour tendencies or traits that predispose an individual to act in a specific manner (Chamorro-Premuzic & Furnham, 2005). Personality makes people predictive, which is important for establishing mutual trust among them, and hence social relationships. As social animals, our reproductive success and survival depend on the social environment that surrounds us. It is personality that shapes our position in the social environment, and thus, subsequently, determines our survival and reproductive success (Kenrick & Shiota, 2008). This is especially true when it comes to approach/avoidance motivation, which is the main topic of this dissertation.

Personality is usually described by personality traits. There are many traits derived from different personality theories and models. Hence, people can be described in numerous ways. However, some traits are found more relevant than the others. Among many theories and models, there are few that have tradition as long as the Reinforcement Sensitivity Theory (RST) of Personality, whose validity is examined in this doctoral dissertation.

1.2. Historical and philosophical background of RST

What is the core of personality traits? Are personality traits placed somewhere in the body, and if they are - where exactly? This question has a long history in philosophical discussions. The first who explored this question was Galen, in second century CE. He reinterpreted the theory of Ancient Greek's philosopher Hippocrates (four centuries BCE), who claimed that human body contains four basic humours (body fluids) that can have an impact on health. These body fluids were blood, phlegm, yellow and black bile. Galen extended this theory by associating these fluids with some typical behavioural patterns, which in return became the first temperamental typology in the history. The Hippocrates-Galen typology recognised four types of temperament named after dominant bodily fluid; sanguine, choleric, melancholic and phlegmatic. Sanguine reflects the description of warm, pleasant individual enjoying the company of others, choleric of hot tempered and highly reactive (aggressive) one, phlegmatic of one that's slow-moving and apathetic, whereas melancholic of slow-moving and depressed one (Stelmack & Stalikas, 1991). Strelau (2002) highlights two main ideas of this typology that

significantly contributed to the study of biological basis of personality. The first one is that individual differences in behaviour can be explained by physiological mechanisms. The second idea is that a variety of behaviours can be reduced to a small number of basic concepts, which is the fundamental logic of factor analysis. Almost two thousand years later, this remained the core approach to the study of biological basis of personality.

The Hippocrates-Galen typology remained dominant for a long time. It was Wundt (1897) who reorganized the description of Galen-Hippocrates types into a two-dimensional perspective. He recognised the importance of strong versus weak emotions and the speed of activity (changeability) (Revelle, Wilt, & Condon, 2013). Sanguine individuals were described as stable and changeable, choleric ones as unstable and changeable, melancholic as unstable and unchangeable ones, whereas phlegmatic individuals were stable and unchangeable (see Figure 1). Later, Carl Jung coined the term *extraversion* to replace the changeability dimension. Extraversion was also used by Cattell, while Eysenck, in addition, introduced *neuroticism* as a new label for the degree of strength of emotion.

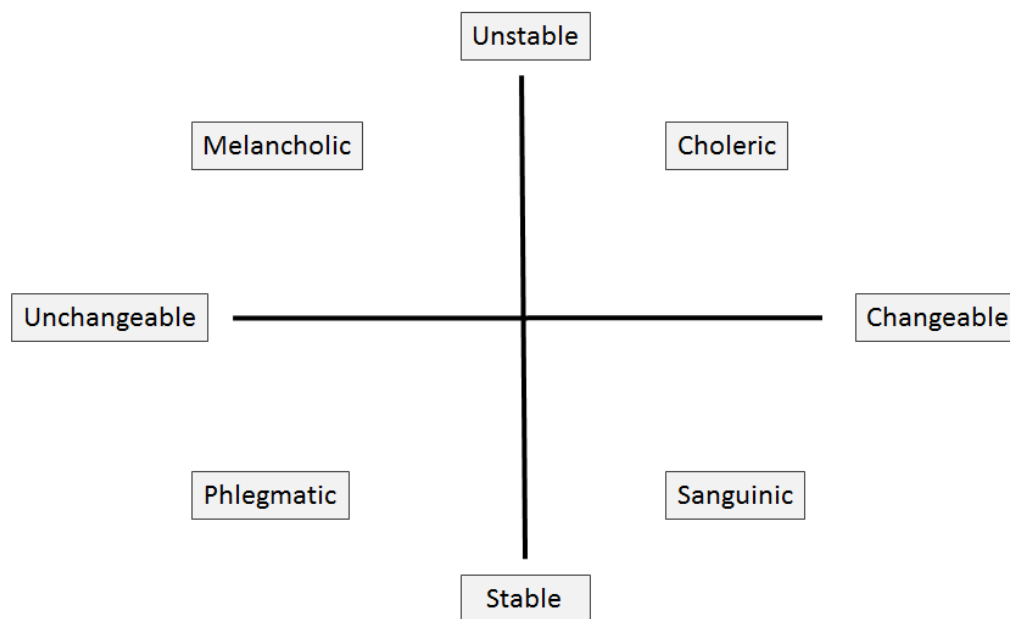

Figure 1. Wundt's coordinates explaining Hippocrates-Galen typology of temperament

Eysenck's work was highly inspired by Pavlov, one of the pioneers of the experimental study of temperament, who studied the relationship between the central nervous system and differences in temperament. In his famous experiments with dogs, he related certain characteristics of the conceptual nervous system (CNS) with the Hippocrates-Galen temperamental types. He described the CNS of sanguine individuals as strong, balanced and stable; strong and unstable in choleric; strong, balanced and slow in phlegmatics; and weak in

melancholics (Ruch, 1992). Later, Pavlov's work inspired Eysenck to develop one of the most influential personality theories in the 20th century. His interest was to discover the biological basis of extraversion and neuroticism. According to Eysenck, melancholics were described as neurotic introverts, choleric as neurotic extroverts, phlegmatics as emotionally stable introverts, whereas sanguines as emotionally stable extroverts (Ruch, 1992).

Following Pavlov's and Hull's work, Eysenck tried to explain personality in terms of susceptibility to punishment and rewarding cues. Hull (1952) assumed that human behaviour could be explained by this simple formula;

$$\text{Behaviour} = \text{Drive} \times \text{Habits}.$$

According to Hull, *Drive* acted as the energizer of behaviour, while *Habits* were responsible for directing said behaviour. Eysenck's theory of personality highly relied upon Hull's theory of motivation. Eysenck defined neuroticism as individual differences in the energizer of behaviour, which corresponded to Hull's *Drive* concept, whereas his extraversion/introversion continuum was intended to explain the susceptibility to reward or punishment, which corresponded to Hull's the *Habit* construct. Figure 2. shows the susceptibility to reward and punishment for the four types of temperament derived by combining extraversion and neuroticism. The main idea was that the behaviour of extraverts is easily conditioned by rewards, of introverts by punishment, while the strength of conditionability depends on the level of neuroticism (Corr, 2008).

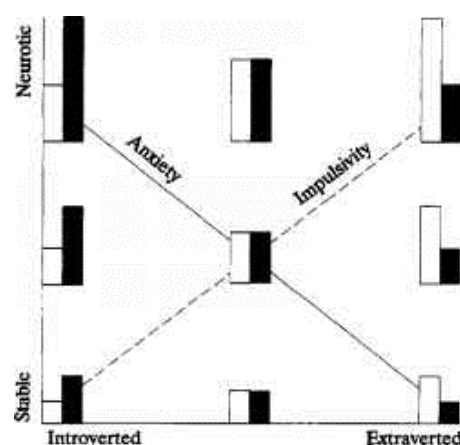

Figure 2. Eysenck's theory explaining extraversion and neuroticism by sensitivity to punishment (black column) and reward (white column). Gray's dimensions the BAS and BIS are presented as impulsivity and anxiety, respectively (explained in the text below).

Contrary to Eysenck's theory, his student Jeffrey Gray proposed that the approach in which the personality is explained through two mechanisms, one energizing (i.e. *Drive*) and one directive (i.e. *Habit*), should be replaced by one that utilises two independent systems – one reflecting reward sensitivity and the other reflecting punishment sensitivity. These two systems were later named behavioural approach system (BAS) and behavioural inhibition system (BIS) (Corr, 2008).

1.2.1. Original reinforcement sensitivity theory (o-RST)

Psychology in the 1970-s was highly influenced by behaviourism which is why Gray's theory aimed to explain personality in terms of susceptibility to reward and punishment. At the beginning, the theory was based on the idea that the BAS represents the biological foundation of the system responsible for processing positive and negative reinforcers, whereas the BIS processes positive and negative punishments (Corr, 2008). Later, Gray has noticed the difference between fear and anxiety reactions. Based on laboratory experiments on rats, he found that the brain centres for fear and aggression are placed in regions different than those for anxiety (i.e. septohippocampal circuit). Thus, he introduced the third dimension into the theory - Fight-Flight System (FFS). Conceptualization of the FFS was based on Kluver-Bucy syndrome, which occurs as the result of amygdalotomy (McNaughton & Corr, 2008). When amygdala was excited by electrodes, an animal would show extreme fight and fear reactions, while after destroying the amygdala, these reactions wouldn't occur in situations in which they were expected (e.g. when faced with a predator). However, reactions that correspond to anxiety were intact after amygdalotomy. This was the reason for including another avoidance mechanism along with the BIS in the theory. few decades later, a large number of studies have provided evidence that fear and anxiety do differ in manifestation, brain locations, biochemistry, and are explained by different psychological mechanisms (*a comprehensive review on this topic can be found in Corr & McNaughton, 2012*).

This theory is quite untypical in personality psychology. Gray used the bottom-up approach in developing his theory of personality (Smillie, Pickering, & Jackson, 2006), which is not common. Most of the theories use the top-down approach, where personality traits are usually defined by means of factor analysis, and then their underlying processes are studied. Gray decided first to establish the link between the brain and behaviour, and then to conceptualise the final description of the dimensions. He defined RST dimensions as emotional-

motivational systems of the highest order, and personality traits as factors of the lower order that derive from them (Beauducel, Kersting, & Liepmann, 2005). The final version of the theory defined the BAS to be sensitive to conditioned appetitive stimuli, activated by the stimuli associated with reward and omission of punishment and related to positive affect. It was hypothesised that impulsivity is the personality trait representing the BAS. The BIS was hypothesised to be sensitive to conditioned, and the FFS to unconditioned aversive stimuli (Corr, 2008).

However, since Gray's work was mostly based on laboratory studies on rats, many researchers have questioned how these findings relate to human personality. Faced with growing criticisms, Gray shifted the focus of his research from animal to human studies at the beginning of the 1990s.

1.3. Revised RST (r-RST)

Changing the subjects in RST research inevitably led to the shift in methodology. Instead of observation of behaviour of rats with selective lesions in laboratory conditions, new methods and instruments were required. Faced with this challenge, Jeffrey Gray and colleagues undertook a decade of studies that led to the refinement of the theory. In 2000, Jeffrey Gray and Neil McNaughton summarised all the data from the aforementioned studies and presented the revised RST (r-RST; Gray & McNaughton, 2000). There are two main groups of changes in the revised theory; (a) redefinition of the BAS, BIS and FFS dimensions and (b) introducing the concept of interactive functioning of the systems.

1.3.1. Redefinition of the RST dimensions

In the o-RST, the BAS processed only conditioned stimuli, while in the new version its functions were spread over the unconditioned ones as well. Furthermore, Gray hypothesized that impulsivity underlies the BAS in o-RST. As Pickering and Smillie (2008) noted, this was set purely arbitrarily without firm evidence. Later studies in biology of personality point to extraversion as the most likely candidate for the representation of the approach-related trait (e.g. Depue & Collins, 1999). However, since this topic awaits for neuroscientific evidence, the

personality trait truly representative of the BAS is a controversial theme (see Pickering & Smillie, 2008).

The FFS has become Fight, Flight and *Freezing* System (FFFS). This change was mostly motivated by works of Blanchard and colleagues (e.g. Blanchard, Griebel, Henrie, & Blanchard, 1997), where freezing was postulated as a unique defensive behaviour observed in animal studies. The FFFS in the revised version of the theory is now responsible for processing both conditioned and unconditioned aversive stimuli, while the FFS was responsible only for the unconditioned ones. In r-RST, the function of the FFFS is to enhance the chance of survival in a dangerous situation. Its behavioural repertoire highly depends on environmental context (Krupić & Dinić, 2017). Flight response is the unconditioned type of defensive behaviour that is triggered in situations where threatening stimuli are distant enough to provide a secure escape. It enhances the chance of survival by moving the organism away from the source of the threat. Freezing is the second unconditioned type of defensive behaviour. It activates when the source of the threat is in near spatiotemporal distance, thus removing an option to escape. Freezing or "playing dead" enhances the chance for survival by reducing tonic mobility in order not to attract the attention of the predator. The final option, the fight, occurs when the organism is spotted by a predator and has no option to escape. In such situations, fighting against the predator would have the purpose of afflicting damage to the predator in order to create an opportunity for escape (McNaughton & Corr, 2012).

The most significant changes were related to the redefinition of the BIS. It is still the central concept explaining anxiety, but, instead of punishment cues postulated by o-RST, the triggers that activate it are conflicts. The conflicts arise from having to choose between approaching and avoiding goals, but also when having to choose between approach-approach and avoidance-avoidance goals. The ambiguity of the situation, present when having to choose between several options/goals, is common to all three types of conflict. This is followed by an increase of arousal (i.e. physiological symptom of anxiety) that motivates an individual to make the decision. Hence, the role of the BIS in r-RST can be seen as a conflict detection and resolution system. When a conflict is detected, the BIS inhibits proponent behaviour, elevates arousal and directs attention toward the source of the conflict. The BIS and FFFS are strongly related because it was more adaptive to avoid uncertain stimuli that could cause some considerable damage, than to recklessly approach them (Corr, 2008). Figure 4 shows the dynamics of the BIS in action.

Even though the BIS and FFFS are strongly related (*see Elaboration section*), the r-RST emphasizes the four key arguments why they should be studied as separate systems. Firstly,

they differ in the defensive direction they promote. The BIS potentiates risk analysis and a cautious approach toward aversive stimuli, while the FFFS potentiates avoidance of the aversive stimuli (Perkins, Cooper, Abdelall, Smillie, & Corr, 2010). Secondly, different types of psychopharmacological drugs eliminate symptoms of anxiety and symptoms of panic attacks, suggesting different neurobiological foundations of the BIS and FFFS (Gray & McNaughton, 2000; McNaughton & Corr, 2004). Thirdly, the FFFS and BIS are located in different brain regions (Gray & McNaughton, 2000). Fear and anger brain circuits are located in the amygdala, whereas anxiety in the septohippocampal system (McNaughton, 1982). In addition, recent studies emphasise the importance of the prefrontal cortex and the anterior cingulate cortex for the BIS functions, whereas the FFFS is related to the periaqueductal gray matter and the amygdala (Amodio, Master, Yee, & Taylor, 2008; Kennis, Rademaker, & Geuze, 2013). Finally, anxiety and fear can be also distinguished by the latency of affect. Anxiety has much longer latency and is less intense than fear and anger (McNaughton & Corr, 2008).

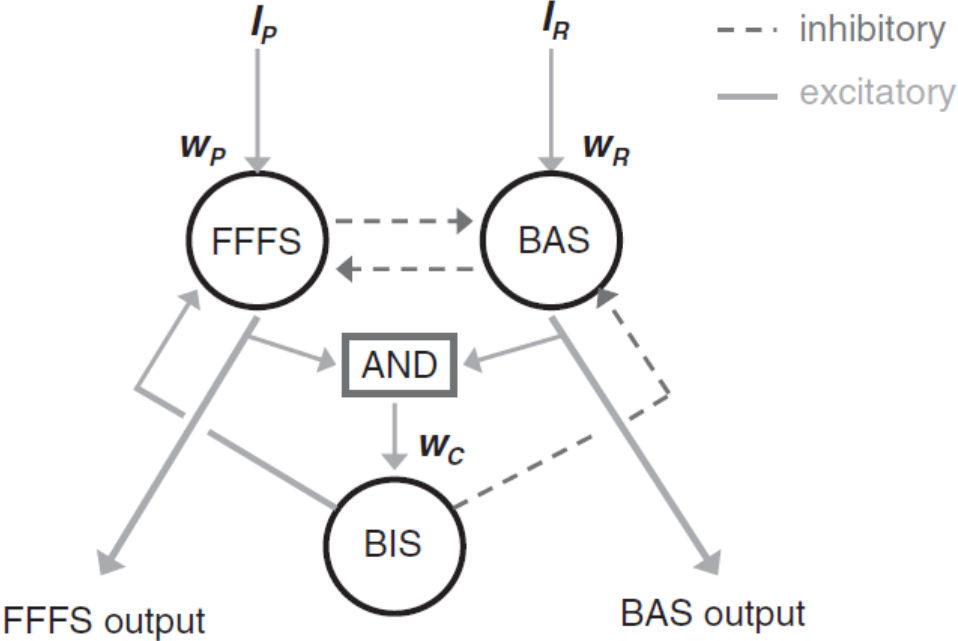

Figure 3. Dynamics of RST dimensions; Dynamics of RST; S_P and S_R - punishment and reward input stimuli; w_R , w_P and w_C reaction of the reward, punishment and conflict system, respectively; “I” in the middle of the figure represents the interaction between the BAS and FFFS that evokes conflict and consequently the BIS. Depending on the strength of the stimuli, the BIS would resolve the conflict in favour of the BAS or FFFS (taken from Smillie, Pickering, et al, 2006).

1.3.2. Relations of the BAS with BIS and FFFS

However, Figure 3 displays just one possible relation between the BAS and BIS/FFFS. There are three hypotheses on how RST dimensions mutually interact. According to the original version of RST, the BAS and the BIS should function independently; the BAS is linked to positive affect (PA) and the BIS/FFFS to negative affect (NA) (Avila & Torrubia, 2008). The independent functioning of the BAS and the BIS/FFFS is known as separable subsystems hypothesis (SSH). After introducing r-RST (Gray & McNaughton, 2000), several studies did not supported the SSH. Consequently, Corr (2001, 2002, and 2004) introduced an alternative joint subsystem hypothesis (JSH) assuming that sensitivity to reward (the BAS) and sensitivity to punishment (the BIS and FFFS) have mutually inhibitory effects (see Figure 3). In other words, activation of sensitivity to reward should inhibit sensitivity to punishment and vice versa (Corr, 2001). Evidence for both hypotheses is mixed. Studies providing empirical evidence for the JSH are Corr's (2002) two experimental studies, studies by Hundt, Nelson-Gray, Kimbrel, Mitchell, & Kwapil (2007) from clinical psychology perspective, Jackson & Francis (2004) psychometric study on religiosity, etc. (for further review see Corr, 2004 and Avila & Torrubia, 2008). On the other hand, Gomez and Cooper (2008), in their review article on mood induction studies of RST, conclude that most of the studies support the SSH against the JHS. That means that mechanisms of sensitivity to reward and sensitivity to punishment are working independently and they correlate exclusively to PA and NA, respectively. However, Gomez and Cooper (2008) reviewed papers conducted with the questionnaires built on o-RST, which makes their review biased.

Besides the SSH and the JHS, there are data that do not fit either of mentioned hypotheses. Harmon-Jones (2003) and Carver (2004) present "velocity" hypothesis (VH), which asserts that either type of motives (approach or avoidance) can give rise to either valence of affect (positive or negative), depending on how well the action serving the motive is going. Carver explains that individuals higher on the BAS can have a higher expectation of positive events; as a result, they are more prone to frustration, anger and sadness in case a situation does not meet their expectations (Carver, 2004; Carver & Harmon-Jones, 2009). Clearly, there is no agreement on how the BAS and BIS/FFFS interacts. The unresolved case of RST dynamics may lie in the problematic operationalisation of the RST construct by self-report questionnaires.

1.3.3. Psychometric operationalisation of the r-RST dimensions

As long as personality models and theories are in question, self-report questionnaires are the most important (and very often the only) measurement instrument. The theory development heavily depends on the validity of the psychometric operationalisation of the main constructs. Currently, the state of psychometric operationalisation of r-RST is incoherent, which is why this doctoral dissertation aims to test the validity of r-RST questionnaires in order to help clear the current confusion in the literature.

1.3.3.1. Undefined standard measure of RST traits

More than fifteen years have passed since Gray and McNaughton (2000) introduced the r-RST, and yet, some of the basic assumptions of the revised theory have not been fully tested and discussed on a conceptual level. Most importantly, psychometric operationalisation of the main dimensions seems to be the Achille's heel of the theory. In its long history, there have been numerous attempts to develop an RST questionnaire (for more details see Torrubia, Ávila, & Caseras, 2008). Currently, six of them are in a use, fact that leads to a reasonable question, also the topic central to this doctoral dissertation: *Which one to use?* The aim of the studies conducted within this dissertation is to acknowledge that the state present in this field of research leads to inconsistencies within RST literature. As a result, the outcome of this dissertation would be to provide a theoretical framework that could enhance the generalisability of studies conducted with different RST questionnaires.

1.3.3.2. Brief review of the current RST questionnaires

The BIS/BAS scales, developed before the revision of the theory (Carver & White, 1994) is currently the most widely used RST questionnaire. It contains only the BIS and BAS scales. Furthermore, the BAS is divided into three subscales named Drive, Fun seeking and Reward responsiveness. Drive reflects the persistence and striving to achieve important goals, Fun seeking is defined as impulsive seeking of fun activities, whereas Reward responsiveness measures individual differences in reaction to the reward. More recently, several authors proposed to divide the BIS scale into the Anxiety and the Fear subscale (e.g. Heym, Ferguson,

& Lawrence, 2008). However, as it will be discussed later in the text, this has not turned out to be a satisfying solution.

Sensitivity to Punishment Sensitivity to Reward Questionnaire (SPSRQ; Torrubia, Ávila, Moltó, & Caseras, 2001) was also developed upon original RST (o-RST; Gray, 1982). It contains the Sensitivity to Punishment (SP) and the Sensitivity to Reward (SR) scales. Several studies showed problematic psychometric properties of the translated versions of this questionnaire. In order to achieve a two-factor structure, many researchers had to adjust the questionnaire by excluding items. This resulted in the original Spanish version containing 48 items (Torrubia et al., 2001), the French version 35 (Lardi, Billieux, d'Acromont, & Linden, 2008), the English version 39 items (Cogswell, Alloy, van Dulmen, & Fresco, 2006); and the Romanian 40-item version had a three-factor solution (Sava & Sperneac, 2006) - in addition to sensitivity to reward and punishment, there was a BAS 'financial' factor relating to earning money. Aluja and Blanch (2011) developed a short version of SPSRQ (SPSRQ-20) in order to enhance its psychometric properties. Except problematic construct validity, the questionnaire is based upon the original version of the RST which assumes impulsivity to be the manifest trait of the BAS. On the contrary, r-RST considers extraversion, rather than impulsivity, as the manifestation of the BAS dimension (Depue & Collins, 1999; Smillie, Pickering, et al., 2006). As will be discussed later, compared to the BIS/BAS Scales, the clearest difference of the SPSRQ is reflected in the definition of the BAS and SR. However, most researchers treat them as synonymous constructs.

1.3.3.3. r-RST questionnaires

The rest of RST questionnaires that will be discussed in this dissertation, are based on revised version of RST. The first one is the Jackson 5 (Jackson, 2009) that comprises five scales: BAS, BIS, Fight, Flight and Freezing. The author's validation data of this questionnaire revealed some theoretically ambiguous results. Firstly, the BAS and BIS scales correlate positively – this is not surprising given that some of the 'BIS' items reflect social comparison or competition (item example "*I aim to do better than my peers*"), content more typical of the BAS. Secondly, the Fight scale is not correlated with the putative FFFS-related Flight and Freezing scales, which creates problems in forming a unidimensional FFFS scale.

The shortcomings of the previous RST questionnaires motivated other authors to develop new, improved ones. Reinforcement Sensitivity Questionnaire (RSQ; Smederevac,

Mitrović, Čolović, & Nikolašević, 2014) consists of five scales, the same as the Jackson 5. In contrast, it shows more theoretically congruent BIS and FFFS scales, but shares the same problem with the Fight scale.

A year later, Reuter, Cooper, Smillie, Markett, & Montag (2015) published their questionnaire named Montag and Reuter Reinforcement Sensitivity Theory Questionnaire (r-RST-Q) with the same factor structure as the two previous r-RST questionnaires, and with content and construct validity similar to the RSQ.

The Reinforcement Sensitivity Theory – Personality Questionnaire (RST-PQ; Corr & Cooper, 2016) contains four BAS subscales: Reward Interest, Goal-Drive Persistence, Reward reactivity, and Impulsivity; the BIS and FFFS scale, accompanied with a separate measure of Defensive Fight. The RST-PQ was based on the r-RST, taking into account previous findings concerning the problematic nature of the Fight scale not correlating with the Flight and Freezing scales.

1.3.3.4. Review of the current findings on differences between RST questionnaires

Differences between the BIS/BAS Scales and SPSRQ are well examined, since these two were published earlier. Cogswell et al. (2006) compared the BIS/BAS Scales and SPSRQ and concluded that these two scales do not measure the same construct and suggested caution in interpreting the data, particularly for the BAS and SR constructs. Other studies also showed that the BAS and SR scales do not converge and that they correlate differently with the Eysenck's EPQ-Impulsivity. However, more congruence exists between the BIS and SP scales (Sava & Sperneac, 2006; Smillie, Jackson and Dalgleish (2006). Cogswell et al. (2006) assume the SPSRQ is a better measure of dimensions within o-RST than the BAS subscales within the BIS/BAS Scales, since the latter do not have a solid conceptual ground. Namely, the three BAS factors have been designed by the results of exploratory factor analysis, not the theory.

Psychometric properties of the new instruments were mostly examined by comparing the instrument in question with the BIS/BAS Scales and SPSRQ. Evidence for the new r-RST questionnaires have been mostly provided by the authors in their validation studies, which will be reviewed later in the Elaboration section. It is important to note that there are earlier studies exploring relation of other RST questionnaires with the BIS/BAS Scales and SPSRQ, such as Knyazev, Slobodskaya, & Wilson (2004) examining Gray-Wilson Personality Questionnaire, or Caseras, Avila and Torrubia (2003) examining General Reward and Punishment Expectancy

Scales (GRAPES; Ball & Zuckerman, 1990). However, these questionnaires are outdated and no longer in use, which is why they will not be discussed any further in this dissertation.

Overall, aforementioned studies indicate clear statistical differences between the questionnaires. At present, these differences are acknowledged, but not studied in detail. Calling for caution in interpreting the data of the BAS and SR scales aside, not much has been done to eliminate the confusion in RST literature. In order to resolve this issue, it should be clear (a) which scales differ and which not, and (b) why they differ, i.e. what they represent.

1.4. Research question, hypotheses and objective

Different operationalisations of the BAS, BIS and FFFS provide evidence for a lack of agreement on how these constructs are measured. The cause of the problem may lie in imprecise definition of the main dimensions. Reasonable, since authors of the questionnaires aimed to improve the operationalisation of the RST dimensions each in his own way, their own operationalisations differed somewhat. Notwithstanding the differences, RST questionnaires are frequently used interchangeably and the differences between them are often neglected. This may, and often does, produce confusion in the RST literature and, consequently, results in the accumulation of knowledge within RST becoming more complicated. This leads to the research question of the dissertation: To what extent can the results of RST studies conducted with different RST-based questionnaires be generalised?

In order to detect and, in addition, to explain the differences between RST questionnaires, series of studies were conducted within this doctoral thesis. At the moment, the issue of different operationalisations within RST has not yet been explored systematically. Thus, the objective of this dissertation is to provide the theoretical framework for the interpretation of the results from RST studies conducted with different questionnaires and to provide suggestions for further development of RST measurement instruments.

In order to meet the main aim of the dissertation, the set of studies was conducted to examine whether and how RST questionnaires differ. Conducted studies focus on differences between various forms of the validity of RST questionnaires. The outcome of the studies will be to provide suggestions and solutions for the psychometric issue concerning RST.

The first study (Krupić, Corr, Ručević, Križanić, & Gračanin, 2016) explores the construct validity and reliability of all above-mentioned questionnaires, except for Reuter et al's (2015) rRST-Q, whose publication post-dated data collection of the studies within dissertation. The main aim was to examine the convergent and divergent validity of the various RST questionnaires. It was expected that the scales aimed to measure the same-named constructs would not load onto the same (corresponding) latent variable in confirmatory factor analysis (CFA). If the null hypothesis were correct, this would prove that various RST questionnaire should not be used interchangeably, i.e. they do not present isomorphic measures of RST dimensions. Thus;

Hypothesis 1 – The same-name scales from five RST questionnaires would not load on the same latent factor in CFA model

More specifically, theoretical model predicts that the BAS scales from Jackson 5, RSQ, BIS/BAS scales (Drive, Reward responsiveness and Fun Seeking), RST-PQ (Reward Interest, Goal-Drive persistence, Reward reactivity and Impulsivity) and the SR from SPSRQ load onto the BAS latent factor. Secondly, the BIS scales from the BIS/BAS Scales, Jackson 5, RSQ, RST-PQ and the SP from SPSRQ load onto the BIS latent factor. Finally, the FFFS scales from Jackson 5, RSQ and RST-PQ load onto the FFFS latent factor (see Figure 5). Any other solution than the aforementioned one would point to a discrepancy between the measurement model and the theory.

The second study (Krupić, Križanić, & Corr, 2016) examines differences between the BIS and FFFS constructs within different RST questionnaires in predicting defensive behavioural reactions. It was predicted that the same name avoidance scales of the questionnaires would have a different predictive validity of the defensive behaviours, i.e. they would predict differently. This was mostly expected due to the difference in operational definition of the BIS scale in the Jackson 5 questionnaire. Logic of this study is quite straightforward. RST scales will be used as predictor, and defensive behavioural reactions as criterion variables, and the relationship between the two will be tested by a series of multiple hierarchical regression analyses. According to r-RST (see above), it is expected that the BIS scales predict defensive orientation toward the source of threat, and the FFFS scales defensive orientation away from the threat. The difference in prediction of defensive behaviours between the questionnaires would suggest that the avoidance scales of RST questionnaires cannot be used interchangeably. Hence;

Hypothesis 2 – Relationship between the BIS and FFFS scales and defensive behavioural reactions depends upon the choice of the RST instrument

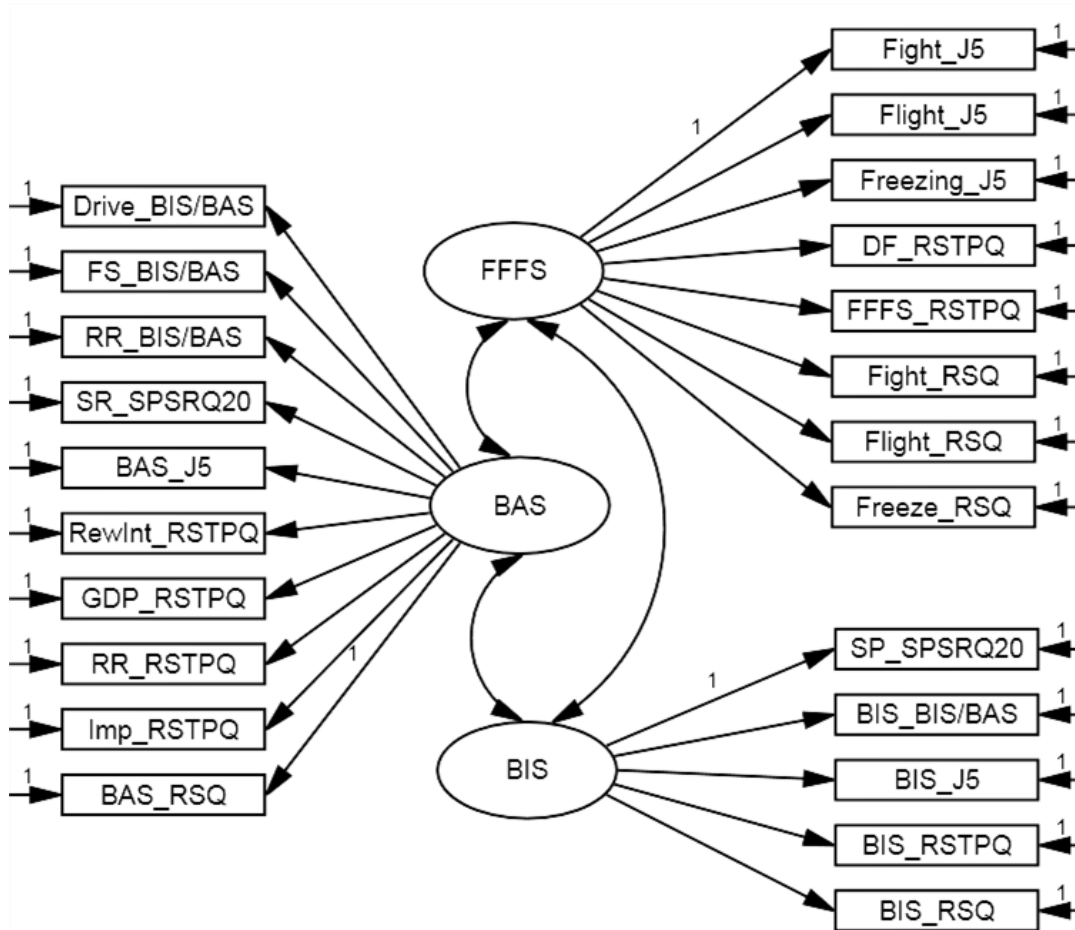

Figure 4. Theory driven model of RST

Note; BIS/BAS – BIS/BAS scales; J5 – Jackson 5 questionnaire; DF_RSTPQ – Defensive fight; SP – Sensitivity to punishment; SR; Sensitivity to reward; FS – Fun seeking; RR_BIS/BAS - Reward responsiveness; RewInt_RSTPQ – Reward Interest; GDP_RSTPQ – Goal Drive Persistence; RR_RSTPQ – Reward reactivity; Imp_RSTPQ – Impulsivity.

The next two studies explore the contribution of RST dimensions in emotion regulation and motivation following positive and negative feedback. The third study (Krupić & Corr,

2014) is a quasi-experimental study examining whether different RST questionnaires predict emotional and motivational reactions to positive and negative academic outcomes differently. It was expected that the BAS and SR differ in the prediction of emotional and motivational responses to positive and negative feedback. This was mainly expected because the SR is operationalised as impulsivity, while the rest of the BAS scales are operationalised more in line to extraversion. Similarly, the fourth study (Krupić, 2016) explores the impact of performance feedback on motivation and self-esteem in correspondence to RST dimensions, but this time in typical experimental settings. This study was expected to replicate the findings of the former study, i.e. it was expected to find the differences in predictive validity between the SR and BAS scales in predicting the emotional and motivational responses to positive and negative feedback. If correct, this would prove that RST questionnaires cannot be used interchangeably in predicting emotional and motivational outcomes after positive and negative feedback.

Hypothesis 3 – RST questionnaires would differ in predicting emotional and motivational outcomes after positive and negative feedback

The fifth (Krupić, Gračanin, & Corr, 2016) and sixth study (Krupić, Banai, & Corr, 2017) examine the differences between the BAS scales in the predictive validity of motivational constructs. The fifth examines correlation of the BAS scales with motives reflecting competitive strategies for resources and mates and cooperative resource acquisition strategies. The sixth study examines relationship between the BAS scales and the fast and slow life history strategies. Both studies aimed to interpret the multifaceted nature of the BAS within evolutionary psychology. It was expected that the multiple dimensions of the BAS have different evolutionary functions, which would prove that the BAS dimensions, as measured by the BAS scales, do not serve the same evolutionary function.

Hypothesis 4 – The BAS scales will correlate with different resource acquisition strategies and life history strategies

2

Elaboration

2. ELABORATION

Since the differences between the six currently used RST questionnaires have not yet been examined, the following section provides a preview of the content validity for the main RST questionnaires. The subsequent section provides a summary of studies conducted within this dissertation, and the final section offers recapitulation of the findings and provides suggestions for the further development of RST.

2.1. Content of approach motivation scales

Four out of the six RST questionnaires currently in use are based on r-RST, and the remaining two use o-RST as their source theory. Whereas the authors of these scales mainly agree on the definition of avoidance scales (*see below*), the definition of the BAS seems to be more problematic.

Lack of conceptual agreement on how the BAS scale should be conceptualised and measured is most obvious in the number of its dimensions. Some authors assume that the scale should be unidimensional (i.e., Jackson, 2009; Reuter et al., 2015; Smederevac et al., 2015; Torrubia et al., 2001), and others advocate the multidimensional perspective (Carver & White, 1994; Corr & Cooper, 2016). In addition, some authors assume the BAS scale should be similar to extraversion (Depue & Collins, 1999; Pickering & Gray, 1999; Smillie, Pickering, et al., 2006), while others propose that it should be more aligned to impulsivity (Torrubia et al., 2001). The cause of this confusion may have arisen from the work of Jeffrey Gray, the author of the o-RST, who suggested that impulsivity reflects the workings of the BAS without providing any strong evidence for that claim (Pickering & Smillie, 2008). Some authors have tried to avoid the confusion in the field by introducing a multifaceted versions of the BAS covering both the extraversion and impulsivity perspective on the BAS.

The first multidimensional operationalisation of the BAS was offered by the BIS/BAS Scales (Carver & White, 1994) in which Drive, Fun seeking and Reward responsiveness subscales were distinguished. These scales had been based on the results of exploratory factor analysis (Carver & White, 1994), not the previous theoretical framework. In terms of correlations with the Big Five model, extraversion relates to all three scales, agreeableness to Reward responsiveness, whereas conscientiousness relates positively to Drive and negatively to Fun seeking (Hofmans, Kuppens, & Allik, 2008; Križanić, Greblo, & Knezović, 2015; Segarra,

Poy, López, & Moltó, 2014; Smillie, Pickering, et al., 2006; Smits & Boeck, 2006). These clear differences between the BAS subscales, depicted in relations to the Big Five dimensions, are also reflected in other domains. For instance, the experience sampling study conducted by Križanić and Krupić (2015) revealed that individuals high on Drive exhibit more excitement and attention, Fun seekers elicit higher level of worrying and attention, and lower levels of serenity, while Reward responsive individuals tend to be more cheerful and calm. Notwithstanding many studies indicate the importance of differentiation of the BAS subscales, vast majority of researchers neglect them.

The second multidimensional perspective of the BAS was offered by the RST-PQ (Corr & Cooper, 2016) in which the authors recognized four BAS subscales. According to the authors, Reward interest reflects identification of the biological reinforcers, Goal-Drive persistence encompasses planning behaviour, and Impulsivity captures the final execution of the plan. Finally, Reward reactivity reflects emotional (and self-reinforcing) reactions on receiving the reward (Corr, 2013; Corr & Krupić, 2017). In terms of the Big Five model traits, Reward interest correlates with extraversion and openness, Goal-Drive persistence with conscientiousness, Reward reactivity with extraversion, whereas Impulsivity correlates positively with extraversion and negatively with conscientiousness (Corr & Cooper, 2016).

The remaining RST questionnaires offer unidimensional operationalisation of the BAS. Content of items and operationalisations of the BAS scales within RST questionnaires are displayed in Table 1. Based on the authors' description of the BAS scales, the BAS has been operationalized as;

- (a) openness, or actively searching for new rewarding stimuli (in Fun seeking, the Jackson 5, RSQ, Reward interest and r-RST-Q);
- (b) behavioural component of approaching the reward and fast reactions with no planning (in the SR and Impulsivity);
- (c) persistence and striving for the attainment of the goal (Drive and Goal-Drive persistence);
- (d) emotional reaction to reward receiving (in Reward responsiveness and Reward reactivity).

Table 1. Operationalisations of the BAS scales in the six frequently used RST questionnaires

Questionnaires	Description of the BAS scales
BIS/BAS scales	
Drive	Persistent pursuit for desired goals
Fun seeking	Desire for new goals and willingness to approach to a potentially rewarding event in spur of the moment
Reward responsiveness	Positive responses to occurrence of or anticipation of reward
SPSRQ	Behavioural tendencies in situations that provoke behaviours in order to gain some kind of reward (money, sex, social events and status, etc..)
Jackson 5	Openness to new sensations
RSQ	Sensitivity to signals of reward (closely related to impulsivity) and to new and exciting situations
r-RST-Q	Energetic arousal and approach behaviour toward appetitive stimuli
RST-PQ	
Reward interest	Openness to new experiences and opportunities that are potentially rewarding
Goal-Drive persistence	Maintenance of positive motivation over time when immediate reward is not available
Reward reactivity	Generation and experience of reward
Impulsivity	No planning and fast reactions

2.2. Content of avoidance motivation scales

Even though the theoretical importance of the FFS was recognised in o-RST, the BIS/BAS Scales and SPSRQ do not contain a separate FFS scale. Subsequent RST questionnaires resulted in attempts to differentiate the two avoidance scales – the BIS and FFFS. The Jackson 5 (Jackson, 2009) is the first published RST questionnaire based on r-RST. It contains one BIS scale and three separate Fight, Flight and Freezing subscales. The same factor

structure was obtained in Smederevac et al.'s (2014) RSQ and Reuter et al.'s (2015) r-RST-Q. Somewhat differently, Corr and Cooper (2016) developed three avoidance scales; the BIS, Flight-Freeze system and a separate Defensive fight scale.

Due to refinements of the functions of the BIS in r-RST, scales based on o-RST and r-RST differ in emphasizing either emotional or cognitive aspect of anxiety, respectively. The BIS scale found in the BIS/BAS Scales focuses on worry over future events, while the SP from the SPSRQ additionally includes behavioural inhibition (not acting as a result of potential punishment). The rest of r-RST questionnaires contain items of the BIS scales reflecting uncertainty intolerance and indecisiveness in order to capture the BIS goal detection and resolution functions. A more comprehensive definition of the BIS is presented in RST-PQ, which covers both the affective and cognitive processes of anxiety. Unlike any of the aforementioned questionnaires, the Jackson 5 is the only one that defines social competition as a manifestation of the BIS. Table 2 summarises operational definitions of the BIS for each of the six RST questionnaires.

Table 2. Operationalisation of the BIS scales in six RST questionnaires

Questionnaires	Description of the BIS scales
BIS/BAS scales	Worry or concern over possibility of bad occurrence
SPSRQ	Worry produced by the threat of potential punishment or failure; behavioural inhibition (passive avoidance) in general situations involving the possibility of aversive consequence or novelty
J5	Sensitivity to uncertainty, social comparison
RSQ	Coping capacities with the conflicting situation
r-RST-Q	Inability to bear uncertainty or often being indecisive
RST-PQ	Motor interruption, behavioural caution/risk assessment, worry

As mentioned, besides the outdated Gray-Wilson Personality Questionnaire (Wilson, Barrett, & Gray, 1989), only the r-RST questionnaires contain the FFFS scales. All four r-RST questionnaires contain items that emphasize defensive behavioural reactions in threatening situations. Ambiguous threat situations tend to elicit risk assessment (Blanchard, Blanchard, & Rodgers, 1991), which in turn is assumed to represent the BIS behavioural output. In a clearly

dangerous situation, fast avoidance responses, such as flight, freeze or defensive fight, are more appropriate (Bracha, 2004). More specifically, the flight would be appropriate in a situation in which a clearly dangerous or alarming stimulus is distant enough to provide space for escape or concealment. However, if the stimulus is in a near spatio-temporal distance, tonic immobility or freezing will be the best way to not attract the attention of the source of threat (Schmidt, Richey, Zvolensky, & Maner, 2008). For example, if a predator/bully is very near and has spotted a prey/victim (i.e. it cannot escape nor "pretend dead" anymore) the only option for the prey/victim is to try attack the predator/bully (Krupić & Dinić, 2017; McNaughton & Corr, 2008).

According to the validation studies of the questionnaires (Corr & Cooper, 2016; Jackson, 2009; Smederevac et al. 2014), the Flight and Freeze scales are highly correlated, but the Fight scale is uncorrelated with the mentioned scales. This is the case in all four r-RST questionnaires containing the FFFS subscales. This was recognised in RST-PQ, where the Fight scale is designed as a separate scale (Corr & Cooper, 2016). The zero correlation between the Fight and Flight-Freeze is not in concordance with the theory, i.e. it represents the mismatch between the theory and measurement. If the scales are not correlated, then they cannot be observed as a unique system with the same underlying brain-behavioural system. In contrast, neuroimaging studies on animals show that these behaviours are rooted in the same brain areas (Gray & McNaughton, 2000). The cause of this problem may lie in poor operationalisation of the scales or a lack of language expressions that could provide differentiation between defensive and instrumental types of aggression (Corr, 2013).

2.2.1. Summary

Six RST questionnaires that are currently in use differ in operationalisations of the BIS and BAS constructs. In general, the o-RST based questionnaires define the BIS as tendency to worry about potential negative events, while questionnaires based on r-RST emphasize the cognitive processes such as rumination, goal-conflict resolution and decision-making. Only the BIS from the Jackson 5 contains items reflecting social competitiveness. More agreement is found for the FFFS scales in r-RST questionnaires, all of which contain items reflecting behavioural tendencies in various threatening situations. On the other hand, the BAS scales show a greater variety of operationalisations; the BAS/BIS Scales and RST-PQ offer a multidimensional, while the others offer a unidimensional perspectives on the BAS. In addition,

subsequent questionnaires also differ in content validity of the BAS scales. Some of them emphasize the openness to novelty, while the others accentuate the behavioural activation aimed at receiving rewarding stimuli.

2.3. Review of the conducted studies

The next section provides the summaries of studies conducted within the dissertation, as well as the main findings for the validity of five currently used RST questionnaires. The only questionnaire that had not been taken into account was the r-RST-Q, which was published after data collection. It is important to mention that the RST-PQ was officially published a year after r-RST-Q, but it had been used in several studies three years earlier, and had been offered for free usage on the authors' website. Delays in publishing the RST-PQ validity study were caused by the authors' decision to gather as much data regarding its psychometric properties as possible before the final publication. That was the reason it was possible to collect the data using the aforementioned questionnaire before its validity study was published.

2.3.1. Construct and convergent validity of RST questionnaires

In the first of the papers this dissertation is based on, *Five reinforcement sensitivity theory (RST) of personality questionnaires: Comparison, validity and generalization* (Krupić, Corr, Ručević, Križanić, & Gračanin, 2016), the BIS/BAS Scales, SPSRQ, Jackson 5, RSQ and RST-PQ were administered to a sample of N = 821 participants. The study was conducted with two major purposes in mind. The first one was to examine the factor structure of all Croatian translation of the RST questionnaires. Results of the confirmatory factor analysis (CFA) showed that all of the aforementioned RST questionnaires possess adequate goodness of fit indices, which was highly congruent with the original validation studies (see Aluja & Blanch, 2011; Carver & White, 1994; Corr & Cooper, 2016; Jackson, 2009; Smederevac et al., 2015).

The second and central purpose of the study pertains to the convergent validity of the five RST questionnaires. Overall, data confirmed problems with the generalization of the studies conducted with various RST questionnaires. Since this was the first study that

empirically tested differences between RST questionnaires by comparing them in the same study, it raised a number of questions important for the further development of RST.

The CFA latent model composed of scales from the five RST questionnaires resulted in a seven-dimensional solution (Figure 5). Four BAS groups of scales, and three avoidance dimensions, namely the BIS, Flight/Freezing and Fight were identified. Table 3 summarises the results of the CFA analysis. The study suggests that the scales loaded onto the same latent model can be used interchangeably.

The BAS scales, as was previously discussed in section on content validity, were grouped into four related factors. In order to describe each of the BAS groups, they were labelled as wanting, striving, liking and capturing types of the BAS scales. As the four-factor solution highly corresponds to the RST-PQ questionnaire, given labels reflect the multidimensional model of the BAS elaborated in Corr (2008; 2013) (also elaborated in the previous section).

Table 3. Summary of the key findings in Krupić, Corr, et al., (2016) showing the congruence of the scales from the five RST questionnaires

BAS	
Wanting	The BAS from the Jackson 5, RSQ, Reward interest
Striving	Drive and Goal-Drive persistence
Liking	Reward responsiveness, Reward reactivity
Capturing	Impulsivity, the SR
BIS	All RST questionnaires except Jackson 5
Flight/Freeze	All r-RST questionnaires
Fight	All r-RST questionnaires

The CFA model revealed two highly correlated, but still separate avoidance factors - the BIS and Flight/Freeze ($r = .85$). Both the BIS and Flight/Freeze scales showed a high level of congruence across RST questionnaires, since the same-name scales loaded onto the same latent variable. This suggests that, as long as the BIS and FFFS scales are in question, the RST questionnaires can be used interchangeably. However, there is one exception: the BIS-J5, whose content validity is significantly dissimilar to the rest of RST questionnaires BIS scales, as discussed in the previous section. Hence, the results of the studies conducted with different

RST questionnaires concerning the BIS (except BIS-J5) and Flight/Freeze scales do not depend on the choice of an RST questionnaire, i.e. it is possible to generalise the BIS and FFFS findings from RST studies conducted with different questionnaires.

The third avoidance scale concerning defensive fight behaviour is more problematic. Even though Fight scales from the Jackson 5, RSQ and RST-PQ highly converge, positive correlation between the Fight latent variable and approach motivation creates ambiguity because it indicates that the Fight factor represents the approach rather than avoidance construct. Furthermore, the Fight scales do not correlate with Flight and Freeze, even though it is expected that these scales should form the unique Fight/Flight/Freeze System. Thus, the data regarding the Fight scales suggest a mismatch between the theory and measurement of the Fight construct. According to this data, the Fight represent instrumental rather than defensive fight behaviour.

However, a larger problem has occurred with the BAS scales. In general, the data suggest not to use the BAS as a unidimensional construct. Instead of interpreting data in general terms of the BAS activity, data should be interpreted according to the (sub)type of the BAS scales. The results of the study distinguish wanting, liking, striving and capturing types of the BAS scales. Each of those processes has its own definition and role in approaching behaviour. The *wanting* BAS reflects openness to new potentially rewarding stimuli, *striving* describes the persistence in achieving desired plans, liking pertains to emotional arousal on receiving the reward or attainment the goal, and capture represents the final stage of execution of a plan, according to Corr's (2013) model of approach motivation. As such, it can be expected that different BAS scales might act differently in behavioural studies. Using the BAS as an "umbrella term" for all the types of scales would lead to imprecision in interpreting, and consequently in generalisation of the result.

These differences are also important for determining the interaction between the BAS and BIS/FFFS. As explained earlier in the dissertation, the interaction between approach and avoidance systems is not fully defined in the RST literature. The SSH states that these two systems work independently of each other, i.e. they are orthogonal (Gomez & Cooper, 2008), the JSH assumes that these two are in mutually antagonistic interaction (Corr, 2001), i.e. they correlate negatively, while the VH predicts the BAS can generate negative affect (Carver, 2004), i.e. that they correlate positively. According to the correlations between the latent variables displayed in the Figure 5, all three hypotheses are supported. Specifically, the negative correlations between the wanting BAS, BIS and Flight/Freeze factors confirm the JSH; positive correlations between the liking BAS, BIS and Flight/Freeze factors confirm the VH, while zero-

correlation between the striving and capturing BAS factors and the BIS and Flight/Freeze factors confirm the SSH. Given this example, it is not appropriate to use just one of the four available BAS scales in a research and interpret the data in terms of "the general BAS". As seen in the case of the interaction between approach and avoidance systems, the results highly depend upon the choice of the questionnaire or the type of the BAS scale.

To sum up, this study shows that the BAS-J5 and BAS-RSQ highly converge with Reward Interest; Drive converges with Goal-Drive persistence; Reward responsiveness with Reward reactivity; and, finally, Impulsivity with the SR. These findings should be collectively taken into account when interpreting and evaluating findings of studies conducted with different RST questionnaires. The BIS and Flight-Freeze scales highly converge, but the Fight scale contradicts the theoretical assumptions. Overall, these findings support the first hypothesis of this dissertation, i.e. the RST questionnaires do not measure the same constructs.

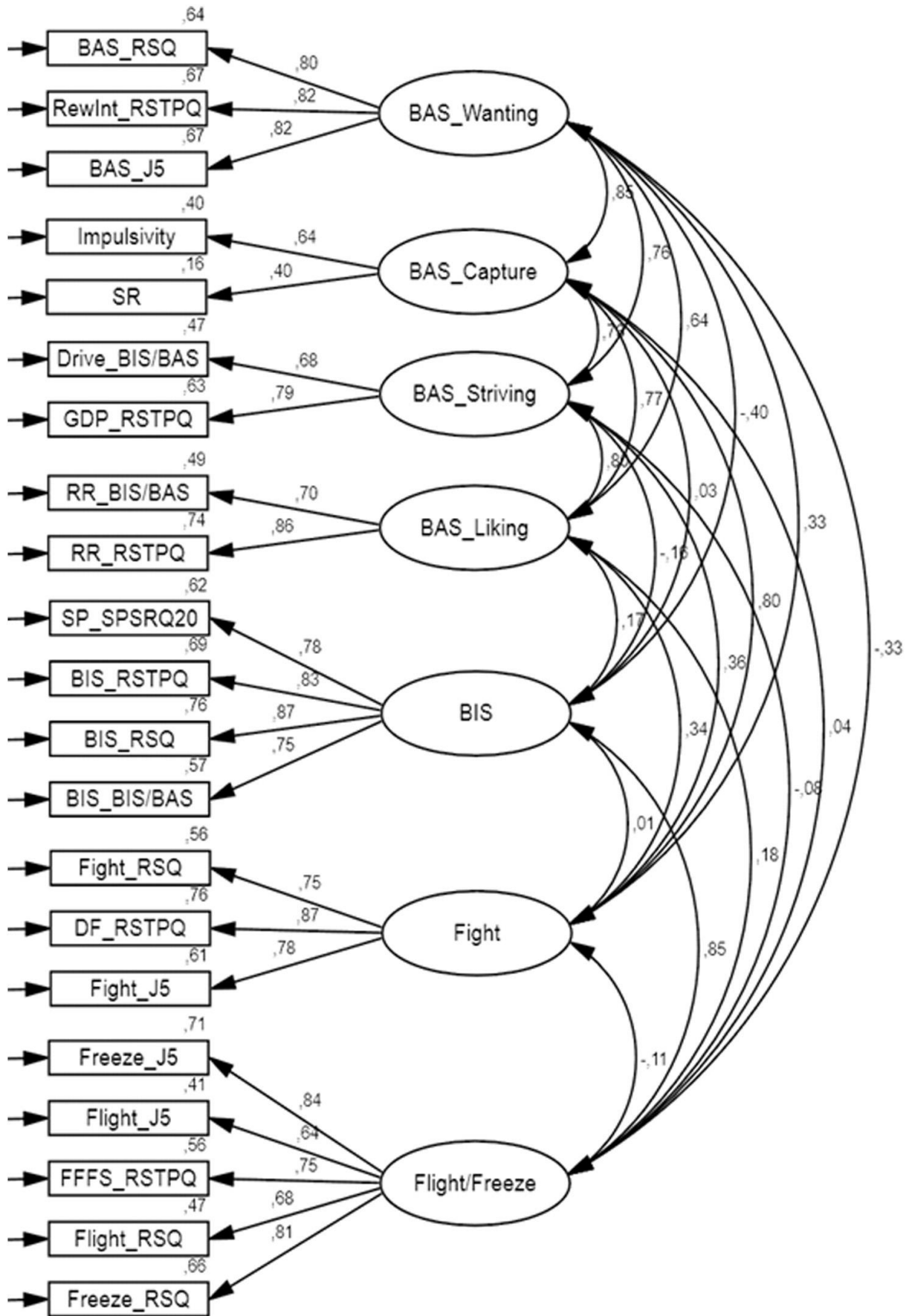

Figure 5. The CFA model of the five RST questionnaires

2.3.2. Predicting defensive behaviours

The second study, *Personality and defensive behaviour: A factor analytic approach to threat scenario choices* (Krupić, Križanić, et al., 2016), examines the role of the BIS and FFFS scales in prediction of the defensive behaviour repertoire. Total of N = 1019 participants completed the BIS/BAS Scales, Jackson 5, RSQ and RST-PQ along with the Blanchards' threat scenarios (Blanchard, Hynd, Minke, Minemoto, & Blanchard, 2001). As found in the previous study, the BIS and Flight-Freeze scales were highly correlated, which challenges the usefulness of separating these two scales. In order to test the predictive validity of the BIS and Flight-Freeze scales, the study examined predictive validity of avoidance scales of RST for defensive behaviours.

This was the first time that the Blanchards' threat scenarios were administered with a modified answer format. Namely, instead of the first-choice method in the original version, we employed the Likert type answer format. This enabled the examination of factor structure of the threat scenarios. The results of exploratory factor analysis (EFA) suggested that the scenarios measure two types of general defensive orientations; approach toward and avoidance from the threat. These composite variables were used as a criterion variable in a series of hierarchical regression analyses.

According to r-RST, the BIS was expected to predict the tendency to approach the source of threat, while the FFFS the tendency to avoid it. Regression analyses were conducted for each of the RST questionnaires independently. This way, it was possible to compare the proportion of explained variance among the questionnaires. The results for BIS scales were quite discouraging, in general. None of the BIS scales from four RST questionnaires predicted the tendency to approach the source of threat. This finding suggest that the BIS scales are inconsistent with the theory, as well as the previous pharmacologic studies (e.g. Perkins et al., 2013), where the application of the anxiolytic drug lorazepam decreased the frequency of risk-assessment behaviour (approaching the source of threat with cautions) in anxious individuals.

The mismatch of the results and theory was explained by inadequate operationalisation of the BIS scales. All four RST questionnaires contain items in the BIS scales that refer to end states of anxiety that are very similar to end states of fear. A more appropriate operationalisation of the BIS scales would probably be achieved if the items were focused on situations that elevate anxiety instead of end states. According to r-RST, when an organism is approaching a threat, anxiety rises, ultimately resulting in a similar emotional state of fear (high negative arousal). On the other hand, fear should emerge the moment the organism perceives the presence of the

threat, and should result in moving away from the threat. In accordance with this view, highly anxious individuals should have a lower threshold of experiencing anxiety when approaching threat situations, while more fearful individuals should express more intense behavioural reaction when the threat is already present. Instead of that, all the BIS scales, except the one from Jackson-5, correlated with tendency to avoid the threat.

On the other hand, there are more congruent findings of correlations between fight/flight/freezing behavioural reactions measured by threat scenarios and RST Flight/Freezing scales. The Jackson-5, RSQ and RST-PQ explain roughly the same amount of variance in tendency to avoid the source of threat. In addition to these three questionnaires, the BIS/BAS Scales were also examined, since in several studies data had been analysed by separating the 7-item BIS scale into two-item BIS-Fear and five-item BIS-Anxiety subscales. Current study shows that such differentiation does not have empirical justification, and that it would be more appropriate to calculate the scores on the BIS/BAS Scales as the authors originally proposed.

As explained above, the EFA of the threat scenarios revealed a two orthogonal factor solution, one factor explaining defensive orientation toward and the other away from the threat. The same situation occurred in the previous study (Krupić, Corr, et al., 2016) with the fight and flight/freezing systems, but also in other RST studies examining defensive behaviour (e.g. Perkins & Corr, 2006). These findings contradict the findings from ethoexperimental studies of defensive behaviours (e.g. Blanchard et al., 1997). The mismatch of the findings between these two scientific disciplines can be attributed to the use of different methodology. The ethoexperimental studies relies on observation of animals' behaviour, while the same behaviour in human is typically assessed by self-report instruments. Thus, it might be that the languages do not contain adequate terms to depict the situation for defensive fight.

To conclude, the RSQ and RST-PQ are the most suitable instruments for use in the study of defensive behaviour at the moment, despite the fact that general conceptualisations within the BIS and Fight scales are not fully consistent with the theory. Regarding the second hypothesis of the dissertation, the findings clearly support the hypothesis, i.e. the RST questionnaires differ in the prediction of defensive behaviours.

2.3.3. Predicting emotional states and motivational outcomes in real life settings

The third paper within the dissertation, *Individual differences in emotion elicitation in university examinations: A quasi-experimental study* (Krupić & Corr, 2014), examined the predictive validity of the RST questionnaires in real-life academic context. Total of N = 94 female psychology students participated in the study during one-semester course *Practice of experimental psychology* in seven repeated measurement time points. During the course, the students underwent seven examinations. The students were completing a short form of Positive and Negative Affect Schedule (PANAS, Watson, Clark, & Tellegen, 1988) measuring current emotional states before writing an exam and after receiving feedback on the exam. Personality traits were assessed at the very beginning of the course, i.e. before the examination series. The aim of this study was to examine predictive validity of the BIS/BAS Scales and SPSRQ in prediction of emotional states before the exam, after receiving a desirable mark and after receiving an undesirable mark. In addition to affective states, data on the effort invested in exam preparation and the level of interest in the course content was collected.

As expected, individuals with high results on the BIS and SP invested more effort, which is in line with the previous proposition that high BIS individuals experience higher rate of anxiety when approaching aversive situation or stimuli. In order to minimize the probability of potentially bad occurrences, anxious individuals invested more time in preparation for the exams. On the other hand, the results of individuals high on Drive, which reflects the striving type of the BAS scale (see Krupić, Corr, et al., 2016), correlated positively, while the SR representing the capturing BAS type correlated negatively with the general level of interest in the course content. In addition, the study revealed an interesting finding that the SR correlated negatively with the effort change after receiving positive test feedback, while the rest of the BAS scales did not correlate. This suggests that Drive and SR might be related with different goal-orientations.

Furthermore, both the BIS and SP correlated positively with negative affect (NA) before the exam, which was interpreted as exam anxiety. The SP, but not the BIS from the BIS/BAS Scales, correlated with NA after receiving an undesired mark. In this case, high BIS individuals performed in line with the prediction of r-RST - they experienced higher NA when approaching to threat, i.e. before an aversive event. The NA following the negative outcome was interpreted as a consequence of the FFFS activation (Corr, 2008). Since the SP predicted NA in both conditions, it acted as the measure of general negative emotionality or neuroticism. Finally, consistent with expectation, Drive correlated positively to PA after positive test feedback, while

the SR correlated positively with NA before the exam and after the negative exam feedback. The results of the SR support the velocity hypothesis predicting the negative affect deriving from the BAS.

Overall, differences in the prediction of emotional and motivational outcomes in educational context are consistent with the conclusion of the previously elaborated studies within the dissertation. Different BAS subscales differently predicted emotional and motivational outcomes following positive and negative performance, which supports the third hypothesis in this dissertation. The BIS from the BIS/BAS Scales predicted NA before examination, as expected, while the SP additionally predicted the NA after receiving negative feedback, suggesting that the SP represents a broader construct than the BIS.

2.3.4. Predicting motivation and self-efficacy after positive and negative feedback in experimental settings

The fourth study of the dissertation, *High BAS and low BIS in overconfidence, and their impact on motivation and self-efficacy after positive and negative performance* (Krupić, 2017) aimed to examine the relationship between the BAS and BIS and overconfidence, and, more importantly, to examine the role of the BAS and BIS in changing motivation and self-efficacy after positive and negative feedback. For the purpose of this study two experimental tasks were conducted on N = 97 female psychology students.

The first task examined whether overconfident individuals have highly reactive BAS and underactive BIS. The results of both the SPSRQ and RSQ reveal that is the case. In addition, this study confirmed that overconfident individuals, having high BAS and low BIS, make more mistakes and undertake higher risks. The second task was maze learning (*see the paper for full description*), where participants' motivation and self-efficacy were measured before and after performance. The results show that individuals with high results on the SR were more motivated for the subsequent task after positive, and less motivated following negative feedback. On the other hand, motivation in high BAS individuals maintained at the same level after either positive or negative feedback. Furthermore, anxious individuals were more demotivated following negative feedback, while the motivation of overconfident individuals tended to increase after negative feedback. These findings suggest that such constellation of the BAS-wanting type and BIS, measured by RSQ, has a potential to explain why overconfident individuals maintain their motivation when faced with negative feedback.

Again, difference between the roles of the BAS and SR in explaining overconfidence suggest that the SR might represent the extrinsic, while the BAS *wanting* intrinsic motivation. In the paper, these data are interpreted within goal-orientation framework. Intact, or even slightly increased motivation after negative feedback, is typical for individuals adopting mastery approach goal orientation. Such individuals seek new and challenging tasks (Senko, Hulleman, & Harackiewicz, 2011), and persist in tasks after negative feedback (Sideridis & Kaplan, 2011). Thus, it is most likely that high BAS-*wanting* individuals adopt mastery-approach goal-orientation, which is related to intrinsic motivation. On the other hand, motivation of performance-oriented individuals highly depends on the performance outcome, which was observed in high SR individuals. Overall, these findings provide another empirical evidence of differential working of the BAS processes, which supports the third hypothesis in this dissertation.

2.3.5. BAS scales predicting evolved individual differences in motivation

The fifth (*The evolution of the Behavioural Approach System (BAS): Cooperative and competitive resource acquisition strategies*; Krupić, Gračanin, et al., 2016) and sixth studies (*Slow and fast BAS: Interpretation of the behavioural approach system (BAS) within Life History Theory*; Krupić, Banai, & Corr, 2017) examined the relationship between the BAS scales and motivation through evolutionary psychology. These studies were conducted separately, and examined only the role of the BAS scales from RST-PQ and SPSRQ in context of evolutionary psychology, leaving avoidance scales aside.

In Krupić, Gračanin, et al. (2016) total of N = 394 participants completed Assessment of Individual Motives Questionnaire (AIM-Q; Bernard, 2013) along with the RST questionnaires. The AIM-Q assess fifteen adaptive motives that are grouped into three main categories; (a) motives facilitating individual integrity, (b) motives facilitating competition for resources and mates, and (c) motives facilitating cooperation. Set correlation analysis revealed unique role of the particular BAS scales, i.e. the scales were differently related to both the resource acquisition strategies and the integrity motives.

Specifically, Reward interest correlated with the tendency to explore the environment, participating in competitions that signal gender-appropriate physical ascendancy, caring for relatives, and with reciprocity among non-kin. In general, individuals high on Reward interest scale show the tendency to act in socially desirable way, and to contribute to society. Goal-

Drive persistence was related to the tendency to enter into reciprocal, mutually beneficial exchanges of resources with non-kin, while the Reward reactivity scales were in relation to the tendency toward maintaining one's safety and a greater capacity for developing tender, intimate, supportive attachments with mates and offspring. Finally, Impulsivity related exclusively to competitive motives, while the SR, in addition to competitive motives, correlated positively with integrity motives and negatively with mutual beneficial exchange of resources with non-kin. Specifically, Impulsivity correlated with motives such as achieving domination, tendency to mock others and being sarcastic in order to elevate one's social status, and searching for mates. On the other hand, individuals high on the SR were more willing to display intellectual and physical superiority, material resources, and to invest resources in order to look well. In general, the common feature of individuals high on Impulsivity and the SR is the tendency to display themselves better than others.

Two main conclusions can be drawn from the study. First, one type of the BAS cannot successfully cover both of evolutionary resource acquisition strategies, which supports the multidimensional perspective on the BAS. Second conclusion falls in line with the interpretation of the previous studies relating striving (Krupić & Corr, 2014) and wanting BAS with intrinsic motivation (Krupić, 2017), which shows that wanting, striving and, additionally, liking types of the BAS scales are related to intrinsic and prosocial motives, while Impulsivity and the SR with extrinsic motivation.

The sixth, and the last study that was conducted on N = 457 participants, supported the conclusions of the results of the previous study from somewhat different theoretical perspective. The same RST questionnaires were used as in the previous study. The study examined the importance of the behavioural approach system (BAS) within life-history theory (LHT). The LHT uses the fast-slow continuum for explaining differences between and within species (Del Giudice, Gangestad, Kaplan, & Gangestad, 2005). Species with "slow" life history strategy reach adulthood and sexual maturity later in life, which is characterized by slow growth, low fertility, long lifespan, and high investment in offspring, while "fast" species are characterized by early maturation and reproduction, fast growth, small body size, high fertility, short lifespan, and low investment in offspring quality (Figueredo et al., 2005). Within human species, the "fast" individuals are perceived exploitative/antisocial, aggressive, less sociable, impulsive, prone to risk-taking, and dominant (Del Giudice, 2014; Wolf, van Doorn, Leimar, & Weissing, 2007; Réale et al., 2010), while the individuals at the "slow" end of continuum are perceived more agreeable, conscientious, and honest (Manson, 2015).

Reward interest, Goal-Drive persistence and Reward reactivity relate to the slow, while the SR to the fast lifestyle. More specifically, Reward interest and Reward reactivity related to the executive functions in terms of insight, planning and control, and with social contact and support, while the SR correlated negatively to positive experience in close relationships. The study suggested that Goal-Drive persistence, Reward interest and Reward reactivity reflect the BAS components that are a prerequisite to planning and achieving long-term goals that characterise slow lifestyle.

Again, on a general level, there is a sharp differentiation between the wanting, striving and liking BAS scales on one hand, and the capture-type of the BAS scales on the other. Only in this instance, the two groups reflect different lifestyles, which is in line with the previous study that related the wanting, striving and liking types of BAS to the cooperative group of motives, and the capture type of BAS to competition. Overall, both studies support the fourth hypothesis of the dissertation.

2.4. Integration of findings and new directions in the theory

The central topic of this dissertation was to explore the psychometric problem of RST. The problem lies in lacking precise operational definitions of the main constructs, which burdens further development of the theory. Without the standard measure, or at least an agreement on operational definition of the constructs, integration of the findings within the theory seems impossible. Currently, researchers around the globe use different RST questionnaires and interpret data as if the dimensions were all defined in the same manner. As it was shown, the questionnaires are not mutually equivalent, a fact that should not be neglected. Hence, the main contribution of the dissertation can be seen in "clearing up the psychometric jungle" which has produced a lot of noise in RST literature in the last decade.

To sum up the negative findings, the RST questionnaires cannot be used interchangeably. The BIS scale from Jackson 5 shows the poorest content, predictive and convergent validity among the BIS scales of RST questionnaires (Krupić, Corr, et al., 2016; Krupić, Križanić, et al, 2016), and thus it is not recommended to use it in the RST studies. Furthermore, splitting the BIS from BIS/BAS Scales into Anxiety and Fear subscales, which was done in several studies past few years (e.g. Heym, Ferguson, & Lawrence, 2008), is also not advisable. The Fear subscale does not predict anything not already predicted in the original scale (Krupić, Križanić, et al., 2016). Furthermore, the BIS scales from the BIS/BAS Scales,

RSQ and RST-PQ highly converge (Krupić, Corr, et al., 2016), but they all lack predictive validity when predicting defensive behaviour oriented toward the threat (Krupić, Križanić, et al., 2016). Aforementioned finding suggests that the BIS should be, not just psychometrically recalibrated, but conceptually redefined within the r-RST in a way that approaching the threat represent a trigger, not a behavioural outcome of the system. However, as stated in Krupić, Corr, et al. (2016), these findings should be re-examined by behavioural experiments, since the threat scenarios fall into the category of self-report instruments as well. On the other hand, a more hopeful prospect of these scales can be seen in the BIS scales from the BIS/BAS Scales, RSQ and RST-PQ successfully predicting emotional states in exam anxiety situation (Krupić & Corr, 2014), and motivational states after negative feedback (Krupić, 2017).

The highest discrepancy was detected in the BAS scales. The conceptual differences are so great, that the prediction of emotional and motivational outcomes almost exclusively depends upon the choice of the RST instrument. This dissertation suggest taking only one type of the BAS scales and interpreting it as the general BAS would be an error. That strongly diminishes the possibility of generalisation of the findings between different studies. In the first study presented in dissertation (Krupić, Corr, et al, 2016), four types of the BAS scales were recognised. They were labelled as the wanting, striving, liking and capturing BAS scales. Further studies supported the importance of recognising different types of the BAS scales. Wanting (Reward interest, RSQ-BAS and J5-BAS), striving (Drive and Goal-Drive persistence) and liking (Reward responsiveness and Reward reactivity), in broader terms, act similarly to intrinsic motivation. However, they reflect more subtly different BAS processes, as underlined in studies predicting emotional and motivational states in academic settings (Krupić & Corr, 2014), motives (Krupić, Gračanin, et al., 2016), and lifestyles (Krupić, et al., 2017). On the other hand, the SR and Impulsivity reflect extrinsic motivation.

One of the reason for the psychometric issue of RST may lie in the bottom-up approach the theory is based on. Most of the empirical work in the original version of RST was based on animal studies, particularly observing behaviours in rats. Based on those experiments, the idea of the unidimensional BAS may have seemed very plausible. However, it is very likely that, during the evolutionary past, highly complex human environment (in comparison to rodents') has shaped multiple BAS processes for solving various kinds of adaptive problems, which are more sophisticated in humans than in other mammals (such as rats).

In addition, it was not possible to observe the BAS-related cognition in animal studies. Since the original version of the theory was built on animal studies, behaviour was typically observed in terms of duration, direction, reaction time, attempts to attain the reward, etc. In

these conditions, impulsivity seemed the most likely representative of the BAS-related traits. However, human approaching behaviour is far more complex than rodents'. One does not necessarily need to walk or run fast to attain the desired goal or to be successful. For example, it would be impossible to operationalize the behaviour of bankers, investors or the President of the USA in terms of physical quality of their behaviour. One can "approach" or attain resources just by sitting and clicking on his computer or placing the signature on a paper (e.g. of some important contract). Hence, the BAS in rats may definitely represent a behavioural system, but in humans, whether the BAS is or is not a *behavioural* system becomes more debatable. The behavioural expression of motivation differs greatly among humans and rats. Thus, the findings from animal studies cannot be simply transferred into findings regarding the BAS in humans. Hence, the main question is: In what terms can we operationalize *behavioural* approach system in humans? Certainly it cannot be measured solely by observing one's behaviour reactions to different stimuli and measuring their time and/or strength. The key to its operationalisation lies in observation and measurement of ones' strength of desire toward the resources – hence the motivation.

In order to provide further development of RST, it is important to: (a) set theoretical framework for the further study of multidimensional BAS; and (b) establish a terminology that would allow the integration of the findings from the RST literature and from the affined scientific areas studying the same constructs. These issues will be discussed in further text.

2.4.1. The multidimensional BAS

A new dynamic model of approach motivation within the RST depicted in Figure 6 summarises the findings of the studies concerning the BAS scales. In general, the model explains both the trait and state levels of approach motivation. But, before introducing the model, the BAS subtypes labelled wanting and capturing in Krupić, Corr, et al. (2016) should be relabelled in order to unify the RST terminology with others scientific disciplines. The wanting label of the BAS subtype is more suitable for the capturing BAS subtypes (the SR and Impulsivity), while incentive motivation better fits the ex-wanting BAS scales (the BAS from RSQ and Jackson 5, and Reward interest). The reasons for the change of labels of the BAS scales are elaborated below. The liking and striving subtypes remain the same (*see Table 4*). Subsequently, the new dynamic model of the BAS is introduced. In order to avoid the confusion with the labels, in further text new labels will be written in *italics*.

Table 4. Redefinition of classification of the BAS scales

	Krupić, Corr, et al. (2016)	The BAS process model	Dominant neurotransmitter or hormone	Motivation	Lifestyle
The SR, Impulsivity	Capturing	<i>Wanting</i>	Testosterone	Extrinsic	fast
RSQ-BAS, Jackson-5 BAS, Reward interest	Wanting	<i>Incentive motivation</i>	Dopamine	Intrinsic	slow
Goal-Drive persistence, Drive	Striving	<i>Striving</i>	Serotonin	Intrinsic	slow
Reward responsiveness, Reward reactivity	Liking	<i>Liking</i>	Endogen opioids	Intrinsic	slow

2.4.1.1. *Wanting* – extrinsic motivation

The SR reflects many characteristics of external motivation. In Krupić, Gračanin, et al. (2016) the SR positively correlated with competitive motives, suggesting that individuals with high results on this scale desire material possessions that would make them look better in comparison to others. Furthermore, in Krupić & Corr (2014) students high on the SR scale showed stronger reaction to positive performance (what was also found in Krupić, 2017), while showing lower level of interest in studying, which also reflects the extrinsic motivation. Therefore, what was previously called the capture type of the BAS (the SR and Impulsivity) shows the characteristics of extrinsic motivation. It manifests as higher desire toward the high-values goals. Behaviour, motivation and emotions of individuals with high results on the Impulsivity and SR scales are highly influenced by external conditions. Their desire for possession of important resources, makes *wanting* seem a more appropriate label for these two BAS scales.

What an impulsive individual wants the most are important resources (such as high social status, wealth etc.) the sooner the better (Krupić, Gračanin, et al., 2016; Krupić et al., 2017). However, without the rest of the BAS processes, he or she cannot attain them. In order to do so, one has to invest his or her time, effort and knowledge needed to attain the goal and

has to be able to cooperate with others. For instance, in politics, economy, and society in general, coalition formation is an important strategy for enhancing the chances of attaining the desired goals (e.g. Bissonnette, Franz, Schülke, & Ostner, 2014). This dissertation has shown that the SR and Impulsivity correlated negatively with the quality of relationship with others (Krupić, et al., 2017; Krupić, Gračanin, et al., 2016). This shows that, strictly speaking, having a wish or a desire for the goal does not actually count as the first step in approach motivation. Wanting without acting is no more than wishful thinking or daydreaming.

2.4.1.2. Incentive motivation

The real "first step" in terms of approaching toward the desired goal is - *incentive motivation*. If someone desires a particular goal, he or she has to develop a plan how to attain it and start acting. The ex-wanting type of the BAS scales (Reward interest, RSQ-BAS, Jackson-5 BAS), as labelled in Krupić, Corr, et al. (2016), dominantly contains items reflecting initiative, proactivity or incentive motivation. This is supported by the study exploring relationship between the BAS and motives (Krupić, Gračanin, et al, 2016) where Reward interest correlated with prosocial motivation such as kin altruism, leaving the legacy to society, and exploring environment. In the second study exploring the evolutionary origin of the BAS, it correlated with slow lifestyle reflecting the orientation toward long-term goals (Krupić et al., 2017). Finally, RSQ-BAS, but not the SR, correlated with initial motivation at the beginning of the task in Krupić (2017), which reflects the incentive motivation. Thus, the BAS scales from the RSQ, Jackson 5 and Reward interest from the RST-PQ reflect intrinsic and *incentive motivation*.

In Krupić, Corr, at al. (2016), the three above-mentioned scales were labelled as wanting scales. This was highly influenced by the work of Berridge and Robinson (2003). They equalize the role of wanting part of the reward system with incentive motivation. However, the findings of this dissertation suggest there is a distinction between incentive motivation and wanting types of the BAS scales. The BAS *incentive motivation* acted as an intrinsic motivation, while the capture, now represented by the *wanting* type of scales, acted as extrinsic motivation (Krupić, 2017; Krupić & Corr, 2014; Krupić, Gračanin, et al., 2016). Since the publication of the highly influential book on intrinsic motivation (Deci & Ryan, 1975), numerous studies confirmed the importance of distinguishing these two types of motivation (e.g. Deci, Koestner, & Ryan, 2001),

which is why their distinction cannot be neglected. Unfortunately, that is currently not the case in the study of the BAS, and neither in the neuroscience of the reward system.

2.4.1.3. Striving

After defining what one wants and deciding to do something about it, the third prerequisite condition for the success is - persistence. Striving toward long-term goals requires (a) inhibition or delay of the short-term immediate gratification and (b) maintaining the initial motivation until the very end – achieving the goal. Hence, it encompasses persistence and self-control capacities. The former reflects motivation, or the will to strive until the very end (i.e. accomplishment). The latter relates to self-regulation capacities of an individual to overcome occasional drops in motivation during the process of attaining the goal. These motivational capacities are a prerequisite for cooperation with others in attaining the goal. This is in concordance to the explanation from the perspective of evolutionary psychology that the ability to delay immediate gratification is the basic condition for maintaining a long-term relationships, which in turn explains the relationship between Goal-Drive persistence and social exchange, and slow lifestyle (Krupić, Corr, et al., 2016; Krupić et al, 2017).

2.4.1.4. Liking

Emotional reaction to the final execution of the plan is measured by *liking*-type of the BAS (Reward responsiveness and Reward reactivity). It represents the emotional part of the BAS and its function is to establish the stimuli-reaction association, i.e. learning/conditioning. In a long run, it reflects the level of satisfaction or wellbeing, i.e. it signals whether the goals from the "wish list" of the *wanting* system have been obtained. According to Baumeister's (2015) circle of satiation, motivation starts with deprivation. When one realizes that he or she wants something that he or she does not possess, the goal occurs on the 'wish list' and the wheel of approach motivation starts to role. It appears that individuals with high results on the BAS-liking are satisfied with their current state, and that this might allow them to "enjoy the moment". Feeling sated with the current material status, they can share more time with their friends and family members, which is line with the findings of Krupić, Gračanin, et al. (2016) and Krupić et al. (2017). In other words, positive emotions produced by the *liking* system, signal that the goal is attained and the pursuing activities can now be stopped.

2.4.1.5. Dynamic model of the BAS

The new proposed dynamic model of multidimensional BAS summarises previously elaborated findings and provides a new theoretical framework for the study of approach motivation within RST.

When a particular goal is detected by the *wanting* system, an individual high on *incentive motivation* starts planning how to attain the goal. The likelihood of success relies on one's persistence, i.e. how long one will *strive* for the goal. Decision when to stop with the activities depends on (a) the level of persistence, i.e. if the activities are stopped before the attainment (quitting) or (b) after the *liking* system signals that the goal is accomplished. If the goal achievement does not trigger the *liking* system, or when the subjective feeling of satisfaction expires, the *wanting* system detects deprivation, or lack of satisfaction, and the approach motivation starts all over again.

The *liking* system in the proposed model has a very important role. It may explain why some individuals continue to work after relatively great accomplishments, and on the other hand, why some individuals do not try to accomplish anything. In this model, the *liking* acts as the "stop button" of the approach motivation. If an individual is satisfied, the *liking* system signals to the *wanting* system that there are no detected deprivations and that the ongoing behaviour can continue. For example, an individual receiving welfare for several years might be satisfied with the current lifestyle. This, however does not motivate him or her to start working on enhancing his or her status. On the other hand, an underactive *liking* system may result in constant pursuit of desired goals detected by the *wanting* system, i.e. those on the "wish list". For instance, inactive *liking* system (assuming hyperactivity of the rest of the BAS systems) may explain why a young and ambitious businessperson continues to work hard after selling his company for several millions of dollars. If his or her sense of accomplishment does not last for long, his or her low-active *liking* system triggers the *wanting* system and the approach motivation starts all over again.

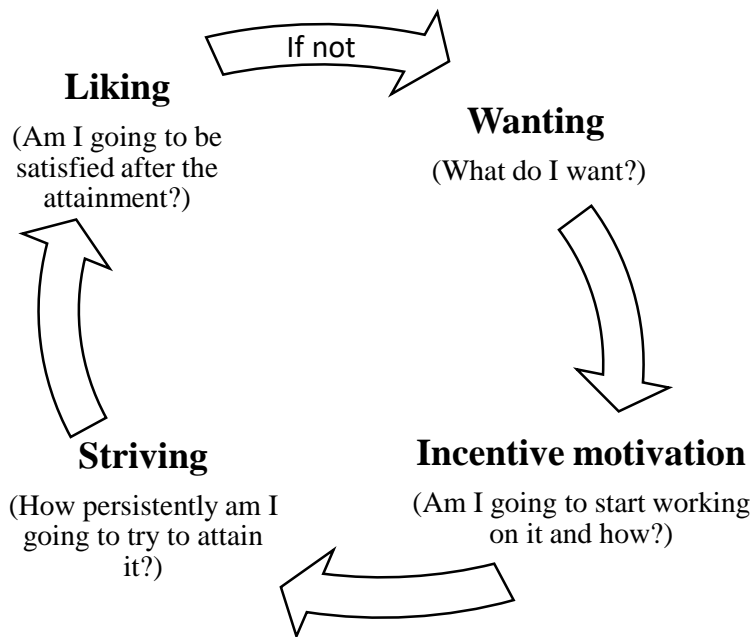

Figure 6. The dynamic model of the multidimensional BAS

The *liking* system is a particularly interesting aspect of the approach motivation. In a number of RST studies, scales reflecting the *liking* system often correlated positively with avoidance scales, a relation also found in Krupić, Corr, et al. (2016). This could be explained by quoting Nobel's laureate Bob Dylan "*When you got nothing, you got nothing to lose*". That is, when people are satisfied with the current position, they are not ready to risk what they have, and vice versa if not satisfied. This was also acknowledged in an earlier study by Isen, Nygren and Ashby (1988) where happy individuals (in this context, high activation of the *liking* system) were not ready for taking risks. The tendency to avoid risk in individuals high on *liking* system is also typical of anxious and fearful individuals. This common feature may explain the positive correlation of the BAS-liking scales with the BIS and Flight-Freeze.

The model above is explained on a state level, i.e. on the system dynamics of achieving one particular goal, while personality traits should reflect more stable individual differences. It is very likely that the same model can also explain more stable tendencies. After all, our judgment of ourselves is based on a number of our past experiences. Hence, the trait level represents stable individual differences in functioning of these systems. Nevertheless, it is important to take into account that the occurrence of fluctuations in the systems depends on the current status of the process of attaining an important long-term goal. For example, two individuals with the same approach motivation would act differently if one of them is in the middle of attaining a better job position, and the other has already been promoted. These

external, or environmental factors (state level), may affect individual's behaviour in experimental studies beyond the trait state measured by RST questionnaires.

2.4.1.6. The BAS components and neurotransmitters and hormones

Recent findings in neuroscience of the reward system support the multidimensional perspective of the BAS. In fact, the study of Krupić, Corr et al. (2016) has been highly motivated by the developments in neuroscience of the reward system. Berridge & Robinson (2003) distinguish the wanting and liking part of the reward system, whose descriptions highly correspond to workings of the BAS. According to Berridge & Robinson (2003), the wanting part of the reward system reflects the *incentive motivation* responsible for planning how to approach or moving toward rewarding stimuli, while *liking* part is responsible for establishing link between the stimuli and subjective experience of pleasure. Deficits in workings of Berridge's wanting and liking parts of the system results in a cluster of symptoms described by Reward Deficiency Syndrome (Blum, Cull, Braverman, & Comings, 1996). These are drug abuse and overeating (Blum, Gardner, Oscar-Berman, & Gold, 2012), anhedonia (Wise, 2008), depression (Tremblay et al., 2005), and schizophrenia (Heinz, Schmidt, & Reischies, 1994) - disorders also related with the underactive SR and BAS.

In the dynamic model of the multidimensional BAS mentioned above, the *wanting* system (the SR and Impulsivity) reflects the motivation for possession of important and extrinsically valorised resources (material resources, social status, mates, etc.) (Krupić, Gračanin, et al, 2016; Krupić et al., 2017), which is highly congruent with previous studies showing that extreme impulsivity is related to instrumental aggression (Antonius, Messinger, & Maile, 2013), gambling (Kräplin et al., 2014), and sex crimes (Mouilso, Calhoun, & Rosenbloom, 2013). All these behaviours are related to testosterone. For instance, the importance of testosterone in attaining social status has been identified in numerous cross-species studies (e.g. Beaver & Amoss, 1982; Cavigelli & Pereira, 2000; Collias, Barfield, & Tarvyd, 2002; Elofsson, Mayer, Damsgård, & Winberg, 2000). In human studies, testosterone predicts domination (Sellers, Mehl, & Josephs, 2007), choice of risky carriers (Sapienza, Zingales, & Maestriperi, 2009), aggression (Harris, Rushton, Hampson, & Jackson, 1996), and investment in reproductive success (Alvergne, Jokela, Faurie, & Lummaa, 2010). All these findings are consistent with the results of the SR and Impulsivity in Krupić et al. (2016) and Krupić et al. (2017). In addition, males are found to score higher on the SR (Aluja & Blanch,

2011; Torrubia et al., 2001) and impulsivity (Cross, Copping, & Campbell, 2011), and are in general more competitive than females (Van Vugt, De Cremer, & Janssen, 2007). These findings suggest that testosterone is the most likely candidate to explain individual differences in *wanting* system (e.g. SR and Impulsivity). However, even though testosterone might play an important or dominant role in the *wanting* system, that role is not exclusive. Along with testosterone (Montoya, Terburg, Bos, & van Honk, 2012), impulsivity is also associated with higher levels of dopamine (Dalley & Roiser, 2012) and low levels of cortisol (Mehta & Josephs, 2010).

The BAS *incentive motivation* scales may reflect individual differences in activity of dopaminergic circuits that underlie incentive motivation (Berridge, 2007; 2012; Depue & Collins, 1999), and in explorative behaviour and novelty seeking (e.g. Dulawa, Grandy, Low, Paulus, & Geyer, 1999). Hence, it is most likely that scores on *incentive motivation* types of the BAS scales reflect individual differences in the activity of dopaminergic brain circuits such as striatal and mesial forebrain structures (including insula, caudate, putamen, and mesial prefrontal cortex), that are found to play an important role in the incentive motivation (e.g. Knutson, Westdorp, Kaiser, & Hommer, 2000).

Striving system may reflect the behavioural manifestations of serotonin. Actually, a recent study (Johnson, Carver, Joormann, & Cuccaro, 2016) provided evidence for the relationship between serotonin and Drive (as representative of *striving*). Serotonin and dopamine highly interact on a neurobiological level (Boureau & Dayan, 2011). Data indicate importance of serotonin in waiting behaviours in prospect of forthcoming rewards (Miyazaki, Miyazaki, & Doya, 2011), delay discounting (Schweighofer et al., 2008), cognitive flexibility (Alexander, Hillier, Smith, Tivarus, & Beversdorf, 2007), and social fairness (Crockett et al., 2013). Similar outcomes are linked to the *striving* scales. Goal-Drive persistence has been found to correlate with reciprocal social exchange (Krupić, Gračanin, et al., 2016) which is a form of social fairness, while Drive has been shown to correlate with higher gratification delay capacities (Corvi, Juergensen, Weaver, & Demaree, 2012). And lastly, the *liking* system (Reward responsiveness and Reward reactivity) appears to reflect the activity of opioid, endocannabinoid, and GABA-benzodiazepine neurotransmitter systems (Berridge, Robinson, & Aldridge, 2009). Currently, only the role of opioids in *liking* has been confirmed in RST literature (Carver, Johnson, & Kim, 2015).

To sum up, based on the literature review and the findings of studies presented in this dissertation, the four BAS processes seem to have a biological foundation, i.e. reflect manifestations of different neurotransmitter systems. The *wanting* system is hypothesized to

correspond to manifestation of testosterone, *incentive motivation* of dopamine, *striving* of serotonin, and *liking* of opioid neurotransmitter system (*for a detailed elaboration see Krupić & Corr, 2017*).

2.4.1.7. Interaction between BAS components

The dynamic model of the BAS provides a new perspective on the approach motivation research within RST. One general dimension can hardly cover the complexity of the BAS. In other words, it is impossible to explain both the extrinsic and intrinsic motivation, both the internal and external loci of control, mastery and performance approach motivation, etc., using only one BAS scale, never mind which one. Multidimensional perspective of the BAS systems covers and explains a greater number of the approach-related processes outside the RST framework and therefore allows for integration of r-RST with other similar theories and scientific fields.

A very important issue in clinical psychology is to determine what is assumed to be normal functioning of approach motivation. Unidimensional models may offer a simple statistical criterion – non-extreme results on the scale. On the other hand, multidimensional perspective can offer much more compelling picture of the BAS activity. For example, a high level of activity of the *wanting* system in combination with a low level of activity of *incentive motivation* system may produce greater levels of frustration. Such individuals would have high aspirations but no incentive motivation that is required to achieve those aspirations. Consequently, it is very likely that those individuals could be prone to disappointments and/or frustration, which can severely affect their mental health. Similarly, high levels of activity of the *wanting*, *incentive motivation* and *striving* with low levels of activity of the *liking* system, responsible for slowing down approach motivation, may lead to workaholism, which in turn can produce serious damage to both mental and physical health (e.g. Schaufeli, Shimazu, & Taris, 2009). Low levels of all BAS scales may explain what Perkins (2016) calls the employment resistant personality – combination of low agreeableness and consciousness traits typical for prolonged users of welfare system. After several years of unemployment, those individuals' life-standard decreases, and consequently, their life goals. That absence of desire for a better life (*wanting* system) may cause further deficits in *incentive motivation* and a lack of persistence towards more important goals.

Above mentioned examples demonstrate potential usefulness of the multidimensional perspective of the BAS. In further development of r-RST it would be interesting to discover specific BAS clusters and to test their discriminative validity. This approach may be useful in research of the BAS, as well as in research of the importance of approach motivation in various clinical disorders such as bipolar disorder (Meyer, Johnson, & Winters, 2001), depression (Kasch, Rottenberg, Arnow, & Gotlib, 2002), schizophrenia (Scholten, van Honk, Aleman, & Kahn, 2006), etc, topics typical for clinical psychology.

2.4.2. The BIS as an emotional rather than cognitive construct

In general, the BIS scales of RST questionnaires (except Jackson 5) are more congruent than the BAS scales. However, all four the BIS scales show theoretically incongruent findings (Krupić, Križanić, et al., 2016). The scales predicted defensive orientation away from the threat instead of defensive orientation toward the threat. As it can be seen in the Table 2, the four RST questionnaires contain items covering anxiety-relevant content such as worry and rumination. That finding is consistent with earlier studies exploring the relationship between the BIS and FFFS and the defensive behaviour repertoire (Perkins & Corr, 2006; Perkins et al., 2010). As such, it propels the theory to reframe the nature of the BIS. Currently, approaching threat stimuli is seen as a behavioural output of the BIS, i.e. it is assumed that approaching to an aversive stimulus is a result of the BIS activation (Corr & McNaughton, 2008). Nevertheless, it is far more likely that approaching an aversive stimulus (situation) triggers anxiety, as it occurred in Krupić & Corr (2014). Therefore, since the BIS is in fact responsible for activating anxiety, and not contrariwise, it is necessary to reverse the causal relationship between approaching toward aversive stimuli and anxiety.

In order to differentiate the workings of the BIS and FFFS by self-report questionnaires, it is important for the BIS scales to contain items focusing on occurrence of elevated arousal before important or stressful events. Typical operationalisations of the BIS in current RST questionnaires contain statements examining the tendency to worry, and, particularly in r-RST questionnaires, indecisiveness, which is in line with the current BIS definition within r-RST emphasizing the role of cognition, i.e. its role in detecting and resolving conflicts. However, the most important function of the BIS is triggering anxiety in situations when one is approaching aversive stimuli, which is an affective, and not a cognitive construct. Thus, the most appropriate BIS items' content should cover the affective output of the BIS, not its

cognitive antecedents. This is particularly important for avoiding criterion-construct contamination. These antecedents should be left for experimental studies exploring which types of situations give rise to anxiety. According to r-RST, in situations when one is deciding between several options in terms of approach-avoidance, but also approach-approach and avoidance-avoidance conflicts, each choice should elevate anxiety. This is similar to the critique of Sensation Seeking Scale (Zuckerman, 2007) which cannot be used in prediction of alcohol consumption, since it already contains items measuring alcohol consumption (Acton, 2003).

2.4.3. The FFFS – panic, not behaviour

All three r-RST based questionnaires that contain Flight, Freeze and Fight scales focus on their behavioural manifestations in specific situations. As seen in Krupić, Corr, et al. (2016) and Krupić, Križanić, et al. (2016), Fight scales do not correlate with Flight-Freeze scales. Hence, the FFFS cannot be studied as a unidimensional construct. One potential explanation is that language lacks expressions which differentiate defensive from instrumental aggression (Corr, 2013). Another one is that defensive aggression occurs only in very specific situations in which the level of mortal danger is extremely high. Fortunately, only a small portion of population has experienced such situations. Hence, answering "how one *might* behave" in such circumstances is mostly based on hypothetical guessing for the majority of participants. On the other hand, for those who have experienced such traumatic situations, reliability of the information based on introspection of such traumatic events is questionable, since in such stressful situation individuals' reaction are rather reflexive than reflective.

So how to assess the FFFS? Situational cues definitely play an important role in defensive behaviour expression (e.g. Krupić & Dinić, 2017). However, people suffering from panic disorders rarely enter situations that may provoke panic-related thoughts and emotions in normal population (Panayiotou, Karekla, & Mete, 2014). Actually, majority of panic attacks come from "inside the body" (Hamm, Richter, & Pané-Farré, 2014), which means that it is not necessary to be in life threatening situations to experience panic. A panic attack can happen even in a harmless situation, e.g. shopping. One does not need to find himself in the middle of a war battlefield to experience the activation of the FFFS. It is reasonable to assume that individuals high on FFFS have a lower threshold for occurrence of panic symptoms, i.e. their FFFS will activate in less dangerous situations. Furthermore, since panic can occur in many situations, trying to cover all representative panic-provoking situations with one instrument

would result in said instrument containing quite a large list of all potentially panic-provoking situations. Hence, the strategy to measure the FFFS by items focusing on behaviours in certain set of situations most certainly has many limitations, and has not turned out to be a good strategy of measuring unidimensional FFFS. Instead, the better way to assess individual differences in the FFFS, hyperactivity of which leads to panic attacks, would be to measure the frequency of occurrence of panic attacks regardless of the situation that caused them. This way, the FFFS would be operationalized as proneness to panic attacks, not as a typical defensive behaviour, i.e. fight, flight and freezing reactions.

2.4.4. Interaction between RST systems

Analysis of the dimensions offers important information on how the approach/avoidance motivation contributes to understanding behaviour. However, said analysis is not sufficient for understanding individual's behaviour, since the systems may interact. The interaction between systems studied under the JHS (Corr, 2001) predicts mutual inhibitory effects between the BAS and BIS/FFFS, under the SSH (Gomez, Cooper, McOrmond, & Tatlow, 2004) predicts independent functioning of the systems, and under the VH (Carver, 2004) predicts negative affect deriving from the BAS. According to Krupić, Križanić et al. (2016) all three hypotheses are accurate, depending on which type of the BAS scale is used.

Wanting system (the SR and Impulsivity) is not correlating neither with the BIS nor with Flight/Freeze scales. On the other hand, it highly correlates with Fight, what suggests that the Fight represents instrumental rather than defensive fight. This shows that *wanting* system acts accordingly to the SSH and VH. In this case the SSH suggests that the level of internal negative affective predisposition (the BIS and Flight-Freeze) of an individual does not interfere with his or her ambition or external motivation. In another words, high ambitions and desires of an individual do not tell us anything about the level of avoidance motivation of that person. On the contrary, the VH assumes that highly ambitious individuals tend to be more aggressive. This could explain zero correlation between the SR and neuroticism, and a negative correlation between the SR and agreeableness (Aluja & Blanch, 2011). According to studies in the dissertation, an individual with high scores on measurements of *wanting* system (i.e. ambition and desire) has a tendency to be competitive (Krupić, Gračanin, et al., 2016) and to have the fast lifestyle (Krupić et al, 2017). Extreme desires in individuals with overactive *wanting* system make them impatient and impulsive – they want their desired goals here and now.

Hence, instrumental aggression may be seen as a mechanism for achieving desired goals in individuals with high scores on measurements of *wanting* system.

Incentive motivation and *striving* act according to the JSH (Krupić, Corr, et al., 2016). These two aspects of the BAS reflect the tendency to act or to move toward the desired goal, and they actually represent the *approach* motivation. The first step in accomplishing desired goals is to develop and initiate action plan, while the second is to strive until the desired goal is attained. Negative correlation with avoidance tendency, compared to *striving*, is stronger for *incentive motivation* (Krupić, Križanić, et al, 2016). This suggests that individuals with high *incentive motivation* are prone to reckless decision making. Study of Krupić (2017) showed that individuals high on the RSQ-BAS (reflecting *incentive motivation*) act with overconfidence when performing the task. They are strongly motivated by potential rewards and are ready to risk more, ignoring the potential punishment. When faced with negative feedback, they tend to strive and risk even more in future attempts to achieve the desired goals.

The difference between *liking* and the rest the BAS systems is in the fact that *liking* comes into action once the pursuit of the goal is over, i.e. when the goal is attained. Individuals with appropriate or moderately high scores on measurements of *liking* system feel satisfied with the current status. They feel they achieved what they wanted and are enjoying the current position. To those individuals, taking risks would jeopardize what they currently have and with which they are satisfied. This may explain why *liking* system correlates positively to internal negative affect produced by the BIS and FFFS. For instance, let us take a look at two individuals who have the same jobs and houses. The individual who is happy with the job and the house he has would avoid taking any risks to lose them. Alternatively, if the job and the house do not meet the desires of the other individual, he or she would have lower activity of the *liking* system, and therefore would be willing to risk said job and house in order to achieve the ones he or she desires. Simply said, general function of *wanting*, *incentive motivation* and *striving* is to achieve something one wants, while the role of *liking* system is to keep what one already possess. In terms of the dynamic BAS model, when (over)active, it acts as the 'stop button' for the rest of the BAS components, or, when underactive, as their 'fuel'.

2.5. Suggestions for the further development of RST

Current state in RST psychometric instruments produces confusion in the RST literature. As elaborated above, current measures do not provide a satisfactory solution to the

problem. To resolve it, RST should continue to search for a questionnaire until the final consensus on the concept of the standard version is reached. In order to aid in attempts to do so, this dissertation offers several suggestions for the development of a new RST questionnaire.

First, it is important to define what the main RST constructs are. Are they emotional-motivational mechanisms or do they represent cognitive or personality factors? As Gray (1982) postulated in o-RST and later in r-RST (Gray & McNaughton, 2000), they should represent general emotional-motivational mechanisms. Therefore, it would be more appropriate if the items in the RST questionnaire exclusively consisted of emotional and motivational content.

Second, it is important to distinguish the core functions of the systems and their antecedents or underlying mechanisms. For example, the BIS in r-RST acts as conflict detection and resolution system. This function should be regarded as its explanatory mechanism, i.e. the explanation how the BIS works, while the main product of the BIS is anxiety. Hence, items in RST questionnaire should assess the likelihood of occurrence of anxiety when approaching aversive stimuli/situation. The mechanism that explains cognitive processes of the BIS should be examined by experimental, not self-report methods. If the items of the BIS contain goal detection and resolution, then the correlation of the BIS with an external criterion variable would reflect method variance, not criterion validity.

Third, the BAS construct should be measured by four interrelated subscales representing *wanting*, *incentive motivation*, *striving* and *liking*. It is particularly important to avoid new and unfamiliar labels of the BAS components. The BAS subscales from the BIS/BAS Scales are actually not rooted in psychological research outside of RST, since most of researchers calculate the total BAS score ignoring the three subscales. By using specific labels, the construct becomes familiar only to researchers within RST, which in turn contributes to isolation of the theory from the rest of the related scientific disciplines. For example, descriptions of the BAS in RST and the reward system in neuroscience are highly similar, but the findings are relatively rarely compared between the two. Moving labels closer to current neuroscientific constructs may motivate researchers from the related disciplines to use the theoretic background of r-RST more often in their studies.

Fourth, the FFFS measured by behavioural manifestations did not yield a satisfactory solution. Instead of focusing on behavioural reactions in life threatening situations, a better solution would be to focus on the occurrence of panic attacks, since separating fight, flight and freezing scales has not resulted with a solution that is in line with the theory.

Fifth, the validation of RST questionnaires should be based on more extensive experimental examinations. Only if the questionnaire reaches adequate predictive validity in

experimental studies exploring motivation, emotion and cognition, should be published. Examining the validity of RST questionnaires only by correlational studies comparing the instrument with other personality scales is not sufficient. The final evidence of validity of an RST questionnaire should be neuroscientific data relating the scores of RST dimensions with proposed neurotransmitters or activity of corresponding brain regions. Until then, the questionnaire should be validated in a number of experimental studies.

Sixth, if RST wants to be used in clinical settings, it would be important to measure tendencies in a span of several months. For example, if an anxious individual receives medical treatment against anxiety, he or she will not exhibit typical manifestations of anxiety in experimental studies. By definition, individuals with high scores on measurements of the BIS should have a higher rate of anxiety-related problems. Consequently, it is more likely that they may be using some sort of anxiolytics. Same goes for individuals with high scores on measurements of the FFFS. Both of those categories of individuals might act atypically due to effects of anxiolytic or panicolytic drugs they may be using. In order to assess them, a questionnaire should measure the activity of RST dimensions in the last few months, and not the stable traits. The same suggestion pertains to the BAS scales. According to the proposed dynamic BAS model, individuals may be in various phases of attainment of an important goal. This may also play an important role in determining behaviour of individuals. To sum up, the level of activity of the brain-behavioural circuits should not be defined as stable individual differences, but rather as broad behavioural tendencies under influence of environmental circumstances.

Finally, the results of an RST questionnaire should be interpreted as a proxy of the activity of main dimensions, since self-report as a method is highly influenced by error variance (Podsakoff, MacKenzie, Lee, & Podsakoff, 2003). As a result, low to moderate effects in laboratory or experimental studies should be expected. Also, the results of the questionnaire should represent the general tendencies of systems, while specific contexts that triggers them should be assessed by other methods. This is especially important if the RST questionnaire is intended for use in clinical or counselling psychology.

3

Conclusion

3. CONCLUSION

Biological foundation of personality has been studied in various scientific disciplines for a long time. From the Hippocrates-Galen typology of temperament, throughout the work of Lock, Wundt, Pavlov and Eysenck, the most recent theory in this historical line is revised Reinforcement Sensitivity Theory (r-RST). The theory aims to relate personality traits with activity of neural circuits in the brain. It recognises three main dimensions; Behavioural Approach System (BAS), Behavioural Inhibition System (BIS) and Fight/Flight/Freezing system (FFFS). Development of the theory is currently slowed down because of unresolved psychometric issues. The lack of agreement on how the RST dimensions should be operationalized has resulted in theoretical and methodological confusion in literature.

Several authors offered their vision of the RST constructs, which resulted in a number of identically named scales measuring RST dimensions quite differently. It can be said that the RST dimensions are currently "lost in translation". Such state in the field diminishes the power of generalization of RST studies and therefore accumulation of knowledge within the theory.

Hence, the research question of this dissertation was – To what level the results of RST studies conducted with different RST-based questionnaires are comparable? Consequently, the objective was to provide the theoretical framework for the interpretation of results of RST studies conducted with different questionnaires, and to provide suggestions for further development of RST measurement instruments. In order to do so, six independent studies were conducted to test four hypotheses. They can be divided into two broad groups – one hypothesis examining convergent and three hypotheses examining predictive validity of RST questionnaires.

Figuratively speaking, the first hypothesis, one examining convergence of RST questionnaires, served as a "snapshot" of the relationship between current RST questionnaires. The aim was to classify or to group scales of RST questionnaires by the level of congruence. This was examined in the first study where five of the most recently developed and most frequently used RST questionnaires (the BIS/BAS Scales, SPSRQ, Jackson 5, RSQ and RST-PQ) were administered on 821 participants. The results were analysed by confirmatory factor analysis (CFA). In case there was a complete agreement among the authors of five RST questionnaires, the CFA would have yielded a satisfactory goodness of fit indices for the three-factor solution measuring the BAS, BIS and FFFS. Any other solution would have proved the discrepancy between RST theory and measurement. In addition, the advantage of the CFA is its capacity to compare appropriateness of several hypothesized models. In this study, the CFA

was used to organize or group congruent RST scales. As predicted, the scales designed to measure the same construct have not loaded onto the same latent variable in confirmatory factor analysis (CFA), which confirmed the first hypothesis. In other words, it was assumed that scales designed to reflect the RST dimensions do not measure the same constructs. The CFA suggested a seven-factor solution as the best fitting model. Out of those seven factors, four correspond to approach, and the rest to avoidance motivation. In a word, this suggests that there are four different operationalisations of the BAS, and three avoidance scales representing the BIS, Flight-Freeze and a separate Fight, while according to the theory, one approach and two avoidance factors were expected. The study supports the conclusion that neither the BAS nor FFFS can be studied as one-dimensional constructs using current RST questionnaires.

Aforementioned study only proves that RST questionnaires are not isomorphic, i.e. they cannot be used interchangeably as they are in current RST literature. However, it does not specify what makes them different. In order to explore their dissimilarity, a set of studies was conducted in order to establish the difference in predictive validity of RST questionnaires. In order to make further reading of the text easier, groups of BAS scales were labelled as *wanting* system (consisting of the SR and Impulsivity), *incentive motivation* (BAS scales from RSQ and Jackson 5, and Reward interest), *striving* system (Drive and Goal-Drive persistence) and *liking* system (Reward reactivity and Reward responsiveness). Since the questionnaires show more congruence in scales of the BIS, Flight-Freezing and Fight, their labels remained the same.

The second study examined the second hypothesis which states that relationship between the BIS and FFFS scales and defensive behavioural reactions depends upon the choice of the RST instrument. According to the theory, it was expected that the BIS would predict defensive orientation toward the source of threat, and FFFS scales defensive orientation away from the threat. On a sample of 1019 participants, four RST questionnaires (same as the previous study except the SPSRQ) were administered along with Blanchard et al.'s (2001) threat scenarios. The results supported the second hypothesis of the dissertation. Out of the four BIS scales, only the BIS scale from Jackson 5 questionnaire did not correlate with defensive tendencies. In addition, the results indicate theoretically congruent findings for the flight and freezing scales and incongruent findings for the BIS scales. This incongruence in findings concerning the BIS encourages changes in the definition of BIS functioning. RST assumes that approaching aversive stimuli is a result of the BIS activation. On the contrary, the results of this study (and several others) challenge that statement. It is more likely that approaching aversive stimuli (situation) triggers anxiety, not the other way around.

The third and fourth studies were conducted to test the third hypothesis, where the role of RST dimensions in emotional and motivational output after positive and negative feedback was observed in respect to different operationalisations of the RST dimensions. The hypothesis predicted that RST questionnaires would differ in predicting emotional and motivational outcomes after positive and negative feedback. The study (Krupić & Corr, 2014) represents a quasi-experimental approach to examining whether different RST questionnaires predict different emotional and motivational reactions to positive and negative academic outcomes. As expected, the BAS scales and SR differently predicted emotional and motivational responses to positive and negative academic outcome. Translated into new labels, *striving* system correlated positively, whereas the *wanting* negatively with general level of interest for studying. Further, *striving* correlated positively to positive affect after positive test feedback, while the *wanting* system correlated positively with negative affect before the exam and after negative exam feedback. In line with the theory, the BIS and SP correlated with negative affect before the exam, and effort invested in exam-preparation, showing higher rate of convergence. The limitation of this study is that no type of *incentive motivation* scale was used.

The hypothesis from the previous study was also examined in the fourth study exploring the role of RST dimensions in motivation and self-esteem after positive and negative feedback in experimental conditions. In addition to the findings of the previous study, the main difference in prediction of emotional and motivational responses after positive and negative feedback was detected between the *wanting* system and *incentive motivation*. The *wanting* system acted as extrinsic, and *incentive motivation* as intrinsic motivation. Individuals with high scores on measurements of the *wanting* system were more motivated after positive and demotivated after negative performance, while those with high *incentive motivation* maintain their motivation after negative feedback.

The final two studies examined the differences between the BAS scales in association to the evolutionary-relevant goals. Both studies tested the hypothesis stating that multiple dimensions of the BAS serve different evolutionary functions. The *wanting* system correlated with motives facilitating competition for resources and mates thus representing fast lifestyle, while the rest of the types of BAS scales correlated with motives facilitating cooperation representing slow lifestyle. Slow and fast lifestyle are concepts stemming from life history theory - a midlevel evolutionary theory explaining individual differences.

As summarised above, RST questionnaires obviously differ in their convergent and predictive validities. Fact that the questionnaires are currently used interchangeably, and that there are no explanations how and why they differ, represents a significant problem for the

theory. Hence, different conclusions (particularly in the case of the BAS) are expected within RST studies depending on the choice of instruments. Such confusing state-of-the-art produces a lot of noise in RST literature.

In order to overcome this problem, this dissertation provides; (a) guidelines how to interpret results from studies conducted with different RST questionnaires; (b) theoretical explanation of different BAS scales that could provide aid in further development of RST; and (c) suggestions for development of the new RST questionnaire that should contain all types of BAS, the BIS and FFFS.

In order to enhance generalisability of findings in RST literature, following scales can be interpreted synonymously: (a) *wanting* – Impulsivity and the SR; (b) *incentive motivation* - the BAS from Jackson 5, RSQ, Reward interest; (c) *striving* - Drive and Goal-Drive persistence; (d) *liking* - Reward responsiveness, Reward reactivity; (e) the BIS - scales from all RST questionnaires except from Jackson 5; (f) Flight-Freeze – scales from all r-RST based questionnaires; (g) Fight - scales from all r-RST based questionnaires, yet its use in r-RST is highly controversial since it represents rather instrumental, than defensive fight.

One of the main theoretical outcome of the dissertation is the dynamic model of the BAS explaining the roles of four types of scales. In the model, *wanting* reflects individual's level of aspirations and desires toward possession of important resources. *Incentive motivation* describes willingness to engage in planning how to attain what one desires. *Striving* explains the duration or persistence in achieving the goal, while the *liking* system signals that the goal is attained. According to the review of the literature and findings of the studies presented in the dissertation, the four BAS processes seem to reflect manifestations of different neurotransmitter systems. The *wanting* system is hypothesized to correspond mainly to manifestation of testosterone, *incentive motivation* to dopamine manifestation, *striving* to serotonin, and *liking* to the manifestation of the opioid neuroendocrine system.

The BIS scales of RST questionnaires (except the ones from Jackson 5) are more congruent. However, some theoretical refinements concerning the output of the BIS are required (*see above*). Similarly, the FFFS scales also show congruence among each other, but Fight scales do not correlate with Flight-Freeze scales, which is quite problematic aspect of the theory.

Suggestions for development of the new RST questionnaire as a viable solution to the RST measurement problem have been proposed. First, the main RST constructs should represent general emotional-motivational mechanisms, which is why the items in the questionnaire should contain exclusively emotional and motivational content. Second, the

questionnaire should focus only on the core functions of the systems, not their antecedents or underlying mechanisms. Third, the BAS construct should contain four interrelated subscales reflecting *wanting*, *incentive motivation*, *striving* and *liking* systems. Fourth, the FFFS should be operationalised as occurrence of panic attacks. Fifth, the validation of RST questionnaires should be based on a more extensive experimental examination. Sixth, in order to improve accuracy of assessment of approach and avoidance constructs, the questionnaire should assess emotional and motivational tendencies in a limited time-period (e.g. several months) instead of the usual trait measuring approach. Finally, the results of RST questionnaires should be interpreted as a proxy for the activity of corresponding brain-behavioural circuits.

4

References

4. REFERENCES

- Acton, G. S. (2003). Measurement of impulsivity in a hierarchical model of personality traits: Implications for substance use. *Substance Use & Misuse*, 38(1), 67–83.
<http://doi.org/10.1081/JA-120016566>
- Alexander, J. K., Hillier, A., Smith, R. M., Tivarus, M. E., & Beversdorf, D. Q. (2007). Beta-adrenergic modulation of cognitive flexibility during stress. *Journal of Cognitive Neuroscience*, 19(3), 468–478. <http://doi.org/10.1162/jocn.2007.19.3.468>
- Aluja, A., & Blanch, A. (2011). Neuropsychological Behavioral Inhibition System (BIS) and Behavioral Approach System (BAS) assessment: A shortened Sensitivity to Punishment and Sensitivity to Reward Questionnaire version (SPSRQ–20). *Journal of Personality Assessment*, 93(6), 628–636. <http://doi.org/10.1080/00223891.2011.608760>
- Alvergne, A., Jokela, M., Faurie, C., & Lummaa, V. (2010). Personality and testosterone in men from a high-fertility population. *Personality and Individual Differences*, 49(8), 840–844. <http://doi.org/10.1016/j.paid.2010.07.006>
- Amodio, D. M., Master, S. L., Yee, C. M., & Taylor, S. E. (2008). Neurocognitive components of the behavioral inhibition and activation systems: implications for theories of self-regulation. *Psychophysiology*, 45(1), 11–19. <http://doi.org/10.1111/j.1469-8986.2007.00609.x>
- Antonius, D., Messinger, J. W., & Maile, J. (2013). Assessing the heterogeneity of aggressive behavior traits: Exploratory and confirmatory analyses of the reactive and instrumental aggression Personality Assessment Inventory (PAI) scales. *Violence and Victims*, 28(4), 587–602. <http://doi.org/10.1891/0886-6708.VV-D-12-00032>
- Ávila, C., & Torrubia, R. (2008). Performance and conditioning studies. In P. J. Corr (Ed), *The reinforcement sensitivity theory and personality* (pp. 228-260). Cambridge: Cambridge University Press.
- Ball, S. A., & Zuckerman, M. (1990). Sensation seeking, Eysenck's personality dimensions and reinforcement sensitivity in concept formation. *Personality and Individual Differences*, 11(4), 343–353. [http://doi.org/10.1016/0191-8869\(90\)90216-E](http://doi.org/10.1016/0191-8869(90)90216-E)
- Baumeister, R. F. (2015). Toward a general theory of motivation: Problems, challenges, opportunities, and the big picture. *Motivation and Emotion*, 40(1), 1–10.
<http://doi.org/10.1007/s11031-015-9521-y>
- Beauducel, A., Kersting, M., & Liepmann, D. (2005). A multitrait-multimethod model for the measurement of sensitivity to reward and sensitivity to punishment. *Journal of*

- Individual Differences*, 26(4), 168–175. <http://doi.org/10.1027/1614-0001.26.4.168>
- Beaver, B. V., & Amoss, M. S. (1982). Aggressive behavior associated with naturally elevated serum testosterone in mares. *Applied Animal Ethology*, 8(5), 425–428. [http://doi.org/10.1016/0304-3762\(82\)90055-4](http://doi.org/10.1016/0304-3762(82)90055-4)
- Bernard, L. C. (2013). Manual for the Assessment of Individual Motives–Questionnaire. *Unpublished manuscript*. Loyola Marymount University, Los Angeles, CA.
- Berridge, K. C. (2007). The debate over dopamine’s role in reward: The case for incentive salience. *Psychopharmacology* 191(3), 391–431. <http://doi.org/10.1007/s00213-006-0578-x>
- Berridge, K. C. (2012). From prediction error to incentive salience: Mesolimbic computation of reward motivation. *European Journal of Neuroscience*, 35(7), 1124–1143. <http://doi.org/10.1111/j.1460-9568.2012.07990.x>
- Berridge, K. C., & Kringelbach, M. L. (2013). Neuroscience of affect: Brain mechanisms of pleasure and displeasure. *Current Opinion in Neurobiology*, 23(3), 294–303. <http://doi.org/10.1016/j.conb.2013.01.017>
- Berridge, K. C., & Robinson, T. E. (2003). Parsing reward. *Trends in Neurosciences*, 26(9), 507–513. [http://doi.org/10.1016/S0166-2236\(03\)00233-9](http://doi.org/10.1016/S0166-2236(03)00233-9)
- Berridge, K. C., Robinson, T. E., & Aldridge, J. W. (2009). Dissecting components of reward: “liking”, “wanting”, and learning. *Current Opinion in Pharmacology*, 9(1), 65–73. <http://doi.org/10.1016/j.coph.2008.12.014>
- Bissonnette, A., Franz, M., Schalke, O., & Ostner, J. (2014). Socioecology, but not cognition, predicts male coalitions across primates. *Behavioral Ecology*, 25(4), 794–801. <http://doi.org/10.1093/beheco/aru054>
- Blanchard, D., Blanchard, R. J., & Rodgers, R. J. (1991). Risk assessment and animal models of anxiety. In B. Olivier, J. Mos, & J. L. Slangen (Eds.), *Animal models in Psychopharmacology* (pp. 117–134). Basel: Birkhäuser Basel. Springer doi:10.1007/978-3-0348-6419-0_13
- Blanchard, R. J., Griebel, G., Henrie, J. A., & Blanchard, D. C. (1997). Differentiation of anxiolytic and panicolytic drugs by effects on rat and mouse defense test batteries. *Neuroscience & Biobehavioral Reviews*, 21(6), 783–789. [http://doi.org/10.1016/S0149-7634\(96\)00062-0](http://doi.org/10.1016/S0149-7634(96)00062-0)
- Blanchard, C. D., Hynd, A. L., Minke, K. A., Minemoto, T., & Blanchard, R. J. (2001). Human defensive behaviors to threat scenarios show parallels to fear- and anxiety-related

- defense patterns of non-human mammals. *Neuroscience and Biobehavioral Reviews*, 25(7–8), 761–770. [http://doi.org/10.1016/S0149-7634\(01\)00056-2](http://doi.org/10.1016/S0149-7634(01)00056-2)
- Blum, K., Cull, J. G., Braverman, E. R., & Comings, D. E. (1996). Reward Deficiency Syndrome. *American Scientist*, 84(2), 132–145. <http://doi.org/10.2307/29775633>
- Blum, K., Gardner, E., Oscar-Berman, M., & Gold, M. (2012). “Liking” and “wanting” linked to Reward Deficiency Syndrome (RDS): Hypothesizing differential responsivity in brain reward circuitry. *Current Pharmaceutical Design*, 18(1), 113–118. <http://doi.org/10.1016/j.surg.2006.10.010>.
- Boureau, Y.-L., & Dayan, P. (2011). Opponency revisited: Competition and cooperation between dopamine and serotonin. *Neuropsychopharmacology*, 36(1), 74–97. <http://doi.org/10.1038/npp.2010.151>
- Bracha, H. S. (2004). Freeze, flight, fight, fright, faint: Adaptationist perspectives on the acute stress response spectrum. *CNS Spectrums*, 9(9), 679–85. Retrieved from <http://www.ncbi.nlm.nih.gov/pubmed/15337864>
- Carver, C. S. (2004). Negative affects deriving from the behavioral approach system. *Emotion*, 4(1), 3–22. <http://doi.org/10.1037/1528-3542.4.1.3>
- Carver, C. S., & Harmon-Jones, E. (2009). Anger is an approach-related affect: Evidence and implications. *Psychological Bulletin*, 135(2), 183–204. <http://doi.org/10.1037/a0013965>
- Carver, C. S., Johnson, S. L., & Kim, Y. (2015). Mu opioid receptor polymorphism, early social adversity, and social traits. *Social Neuroscience*, 11(5), 515–524. <http://doi.org/10.1080/17470919.2015.1114965>
- Carver, C. S., & White, T. L. (1994). Behavioral inhibition, behavioral activation, and affective responses to impending reward and punishment: The BIS/BAS Scales. *Journal of Personality and Social Psychology*, 67(2), 319–333. <http://doi.org/10.1037//0022-3514.67.2.319>
- Caseras, X., Ávila, C., & Torrubia, R. (2003). The measurement of individual differences in behavioural inhibition and behavioural activation systems: A comparison of personality scales. *Personality and Individual Differences*, 34(6), 999–1013. [http://doi.org/10.1016/S0191-8869\(02\)00084-3](http://doi.org/10.1016/S0191-8869(02)00084-3)
- Cavigelli, S. a, & Pereira, M. E. (2000). Mating season aggression and fecal testosterone levels in male ring-tailed lemurs (*Lemur catta*). *Hormones and Behavior*, 37(3), 246–255. <http://doi.org/10.1006/hbeh.2000.1585>
- Chamorro-Premuzic, T, Furnham, A. (2005). *Personality and Intellectual Competence*. London: Taylor & Francis. doi:10.1017/CBO9781107415324.004

- Cogswell, A., Alloy, L. B., van Dulmen, M. H. M., & Fresco, D. M. (2006). A psychometric evaluation of behavioral inhibition and approach self-report measures. *Personality and Individual Differences, 40*(8), 1649–1658. <http://doi.org/10.1016/j.paid.2005.12.008>
- Collias, N., Barfield, R., & Tarvyd, E. (2002). Testosterone versus psychological castration in the expression of dominance, territoriality and breeding behavior by male village weavers (*Ploceus cucullatus*). *Behaviour, 139*(6), 801–824. <http://doi.org/10.1163/156853902320262826>
- Corr, P. J. (2001). Testing problems in J. A. Gray's personality theory: A commentary on Matthews and Gilliland (1999). *Personality and Individual Differences, 30*(2), 333–352. [http://doi.org/10.1016/S0191-8869\(00\)00028-3](http://doi.org/10.1016/S0191-8869(00)00028-3)
- Corr, P. J. (2002). J. A. Gray's reinforcement sensitivity theory: Tests of the joint subsystems hypothesis of anxiety and impulsivity. *Personality and Individual Differences, 33*(4), 511–532. [http://doi.org/10.1016/S0191-8869\(01\)00115-5](http://doi.org/10.1016/S0191-8869(01)00115-5)
- Corr, P. J. (2004). Reinforcement sensitivity theory and personality. *Neuroscience and Biobehavioral Reviews, 28*(3), 317–332. <http://doi.org/10.1016/j.neubiorev.2004.01.005>
- Corr, P. J. (2008). Reinforcement sensitivity theory (RST): Introduction. In P. J. Corr (Ed.), *The reinforcement sensitivity theory and personality* (pp. 1 - 43). Cambridge: Cambridge University Press. doi:10.1017/CBO9780511819384.002
- Corr, P. J. (2013). Approach and avoidance behaviour: Multiple systems and their interactions. *Emotion Review, 5*(3), 285–290. <http://doi.org/10.1177/1754073913477507>
- Corr, P. J., & Cooper, A. J. (2016). The Reinforcement Sensitivity Theory of Personality Questionnaire (RST-PQ): Development and validation. *Psychological Assessment, 28*(11), 1427-1440. <http://doi.org/http://dx.doi.org/10.1037/pas0000273>
- Corr, P. J. & Krupić, D. (2017). Motivating personality: Approach, avoidance, and their conflict. In Elliot, A. (Ed.), *Advances in Motivation Science, Volume 4*. London: Elsevier. *In press*. <http://dx.doi.org/10.1016/bs.adms.2017.02.003>
- Corr, P. J., & McNaughton, N. (2008). Reinforcement sensitivity theory and personality. In P. J. Corr (Ed.), *The Reinforcement Sensitivity Theory of Personality*, (pp. 155-187). Cambridge: Cambridge University Press. doi:10.1017/CBO9780511819384.006
- Corr, P. J., & McNaughton, N. (2012). Neuroscience and approach/avoidance personality traits: A two stage (valuation-motivation) approach. *Neuroscience and Biobehavioral Reviews, 36*(10), 2339-2354. <http://doi.org/10.1016/j.neubiorev.2012.09.013>
- Corvi, A. P., Juergensen, J., Weaver, J. S., & Demaree, H. A. (2012). Subjective time perception and behavioral activation system strength predict delay of gratification ability.

- Motivation and Emotion*, 36(4), 483–490. <http://doi.org/10.1007/s11031-011-9275-0>
- Crockett, M. J., Apergis-Schoute, A., Herrmann, B., Lieberman, M. D., Lieberman, M., Müller, U., ... Clark, L. (2013). Serotonin modulates striatal responses to fairness and retaliation in humans. *The Journal of Neuroscience*, 33(8), 3505–3513. <http://doi.org/10.1523/JNEUROSCI.2761-12.2013>
- Cross, C. P., Copping, L. T., & Campbell, A. (2011). Sex differences in impulsivity: A meta-analysis. *Psychological Bulletin*, 137(1), 97–130. <http://doi.org/10.1037/a0021591>
- Dalley, J. W., & Roiser, J. P. (2012). Dopamine, serotonin and impulsivity. *Neuroscience*, 215, 42-58. <http://doi.org/10.1016/j.neuroscience.2012.03.065>
- Deci, E. L., Koestner, R., & Ryan, R. M. (2001). Extrinsic rewards and intrinsic motivation in education: Reconsidered once again. *Review of Educational Research*, 71(1), 1–27. <http://doi.org/10.3102/00346543071001001>
- Deci, E. L., & Ryan, R. M. (1975). *Intrinsic motivation*. John Wiley & Sons, Inc.
- Del Giudice, M. (2014). An evolutionary life history framework for psychopathology. *Psychological Inquiry*, 25(3-4), 261-300. <http://doi.org/http://dx.doi.org/10.1080/1047840X.2014.884918>
- Del Giudice, M., Gangestad, S. W., Kaplan, H. S., & Gangestad, S. W. (2005). Life History Theory and evolutionary psychology. In D.M. Buss (Ed.), *The handbook of evolutionary psychology* (pp. 68–96). New York: Wiley. <http://doi.org/10.1002/evan.1360020303>
- Depue, R. A., & Collons, P. F. (1999). Neurobiology of the structure of personality: Dopamine, facilitation of incentive motivation, and extraversion. *Behavioral and Brain Sciences*, 22(3), 491–569. <http://doi.org/10.1017/S0140525X99002046>
- Dulawa, S. C., Grandy, D. K., Low, M. J., Paulus, M. P., & Geyer, M. A. (1999). Dopamine D4 receptor-knock-out mice exhibit reduced exploration of novel stimuli. *Journal of Neuroscience*, 19(21), 9550–9556.
- Elofsson, U. O., Mayer, I., Damsgård, B., & Winberg, S. (2000). Intermale competition in sexually mature arctic charr: effects on brain monoamines, endocrine stress responses, sex hormone levels, and behavior. *General and Comparative Endocrinology*, 118(3), 450–460. <http://doi.org/10.1006/gcen.2000.7487>
- Figueredo, A. J., Vasquez, G., Brumbach, B. H., Sefcek, J. A., Kirsner, B. R., & Jacobs, W. J. (2005). The K-factor: Individual differences in life history strategy. *Personality and Individual Differences*, 39(8), 1349–1360. <http://doi.org/10.1016/j.paid.2005.06.009>
- Gomez, R., & Cooper, A. (2008). Reinforcement Sensitivity Theory and mood induction

- studies. In P. J. Corr (Ed), *The reinforcement sensitivity theory and personality* (pp. 291-316). Cambridge: Cambridge University Press.
- Gomez, R., Cooper, A., McOrmond, R., & Tatlow, S. (2004). Gray's reinforcement sensitivity theory: Comparing the separable and joint subsystems. Hypotheses in the predictions of pleasant and unpleasant emotional information processing. *Personality and Individual Differences*, 37(2), 289–305. <http://doi.org/10.1016/j.paid.2003.09.003>
- Gray, J. A. (1970). The psychophysiological basis of introversion-extraversion. *Behaviour Research and Therapy*, 8(3), 249–266.
- Gray, J. A. (1982). *The neuropsychology of anxiety: An investigation into the functions of the septo-hippocampal system*. Oxford, England: Oxford University Press.
- Gray, J. A., & McNaughton, N. (2000). *The neuropsychology of anxiety: An enquiry into the functions of the septo-hippocampal system, Second edition*. Oxford, UK: Oxford Press. <http://doi.org/10.1017/S0140525X00013066>
- Hamm, A. O., Richter, J., & Pané-Farré, C. A. (2014). When the threat comes from inside the body: A neuroscience based learning perspective of the etiology of panic disorder. *Restorative Neurology and Neuroscience*, 32(1), 79–93. <http://doi.org/10.3233/RNN-139011>
- Harmon-Jones, E. (2003). Anger and the behavioral approach system. *Personality and Individual Differences*, 35(5), 995–1005. [http://doi.org/10.1016/S0191-8869\(02\)00313-6](http://doi.org/10.1016/S0191-8869(02)00313-6)
- Harris, J. A., Rushton, J. P., Hampson, E., & Jackson, D. N. (1996). Salivary testosterone and self-report aggressive and pro-social personality characteristics in men and women. *Aggressive Behavior*, 22(5), 321–331. [http://doi.org/10.1002/\(SICI\)1098-2337\(1996\)22:5<321::AID-AB1>3.0.CO;2-M](http://doi.org/10.1002/(SICI)1098-2337(1996)22:5<321::AID-AB1>3.0.CO;2-M)
- Heinz, A., Schmidt, L. G., & Reischies, F. M. (1994). Anhedonia in schizophrenic, depressed, or alcohol-dependent patients--neurobiological correlates. *Pharmacopsychiatry*, 27(S1), 7–10. <http://doi.org/10.1055/s-2007-1014317>
- Heym, N., Ferguson, E., & Lawrence, C. (2008). An evaluation of the relationship between Gray's revised RST and Eysenck's PEN: Distinguishing BIS and FFFS in Carver and White's BIS/BAS scales. *Personality and Individual Differences*, 45(8), 709–715. <http://doi.org/10.1016/j.paid.2008.07.013>
- Hofmans, J., Kuppens, P., & Allik, J. (2008). Is short in length short in content? An examination of the domain representation of the Ten Item Personality Inventory scales in Dutch language. *Personality and Individual Differences*, 45(8), 750–755. <http://doi.org/10.1016/j.paid.2008.08.004>

- Hull, C.L. (1952). *A behavior system*. New Haven: Yale University Press.
- Hundt, N. E., Nelson-Gray, R. O., Kimbrel, N. a., Mitchell, J. T., & Kwapil, T. R. (2007). The interaction of reinforcement sensitivity and life events in the prediction of anhedonic depression and mixed anxiety-depression symptoms. *Personality and Individual Differences*, *43*(5), 1001–1012. <http://doi.org/10.1016/j.paid.2007.02.021>
- Isen, A. M., Nygren, T. E., & Ashby, F. G. (1988). Influence of positive affect on the subject utility of gains and losses: It is just not worth the risk. *Journal of Personality and Social Psychology*, *55*(5), 710–717.
- Jackson, C. J. (2009). Jackson-5 scales of revised Reinforcement Sensitivity Theory (r-RST) and their application to dysfunctional real world outcomes. *Journal of Research in Personality*, *43*(4), 556–569. <http://doi.org/10.1016/j.jrp.2009.02.007>
- Jackson, C. J., & Francis, L. J. (2004). Are interactions in Gray's Reinforcement Sensitivity Theory proximal or distal in the prediction of religiosity: A test of the joint subsystems hypothesis. *Personality and Individual Differences*, *36*(5), 1197–1209. [http://doi.org/10.1016/S0191-8869\(03\)00211-3](http://doi.org/10.1016/S0191-8869(03)00211-3)
- Johnson, S. L., Carver, C. S., Joormann, J., & Cuccaro, M. L. (2016). Genetic polymorphisms related to behavioral approach and behavioral inhibition scales. *Personality and Individual Differences*, *88*, 251-255. <http://doi.org/10.1016/j.paid.2015.09.024>
- Kasch, K. L., Rottenberg, J., Arnow, B. a, & Gotlib, I. H. (2002). Behavioral activation and inhibition systems and the severity and course of depression. *Journal of Abnormal Psychology*, *111*(4), 589–597. <http://doi.org/10.1037/0021-843X.111.4.589>
- Kennis, M., Rademaker, A. R., & Geuze, E. (2013). Neural correlates of personality: An integrative review. *Neuroscience and Biobehavioral Reviews*, *37*(1), 73-95. <http://doi.org/10.1016/j.neubiorev.2012.10.012>
- Kenrick, D. T., & Shiota, M. N. (2008). Approach and avoidance motivation(s): An evolutionary perspective. In Elliot, Andrew J. (Ed). (2008). *Handbook of approach and avoidance motivation*, (pp. 273-288). New York, NY, US: Psychology Press. <http://doi.org/10.4324/9780203888148.ch16>
- Knutson, B., Westdorp, a, Kaiser, E., & Hommer, D. (2000). fMRI visualization of brain activity during a monetary incentive delay task. *NeuroImage*, *12*(1), 20–7. <http://doi.org/10.1006/nimg.2000.0593>
- Knyazev, G. G., Slobodskaya, H. R., & Wilson, G. D. (2004). Comparison of the construct validity of the Gray–Wilson Personality Questionnaire and the BIS/BAS scales. *Personality and Individual Differences*, *37*(8), 1565–1582.

<http://doi.org/10.1016/j.paid.2004.02.013>

- Kräplin, A., Bühringer, G., Oosterlaan, J., Van den Brink, W., Goschke, T., & Goudriaan, A. E. (2014). Dimensions and disorder specificity of impulsivity in pathological gambling. *Addictive Behaviors*, *39*(11), 1646–1651. <http://doi.org/10.1016/j.addbeh.2014.05.021>
- Križanić, V., Greblo, Z., & Knezović, Z. (2015). Mjere osjetljivosti bihevioralnoga inhibicijskog i aktivacijskoga sustava kao prediktori dimenzija petofaktorskoga modela ličnosti. *Psychological Topics*, *24*(2), 305-324.
- Križanić, V., & Krupić, D. (2015). Implementing Reinforcement sensitivity theory in predicting specific affective states in daily life. In International scientific committee for psychology, sociology and education (Ed.). *Psychology and Psychiatry, Sociology and Healthcare, Education Conference Proceedings Volume I*. (93-100). Sofija, Bulgaria.
- Krupić, D. (2017). High BAS and low BIS in overconfidence, and their impact on motivation and self-efficacy after feedback. *Primenjena psihologija*, *10*(3), 297-312. <https://doi.org/10.19090/pp.2017.3.297-312>.
- Krupić, D., Banai, B., Corr, P. J. (2017). Slow and fast BAS: Interpretation of the behavioural approach system (BAS) within Life History Theory. *Journal of Individual Differences*. *Submitted*
- Krupić, D., & Corr, P. J. (2014). Individual differences in emotion elicitation in university examinations: A quasi-experimental study. *Personality and Individual Differences*, *71*, 176–180. <http://doi.org/10.1016/j.paid.2014.08.001>
- Krupić, D. & Corr, P. J. (2017). Moving forward with the BAS: Toward neurobiology of multidimensional model of approach motivation. *Psychological Topics*, *26*(1), 25-45.
- Krupić, D., Corr, P. J., Ručević, S., Križanić, V., & Gračanin, A. (2016). Five reinforcement sensitivity theory (RST) of personality questionnaires: Comparison, validity and generalization. *Personality and Individual Differences*, *97*, 19–24. <http://doi.org/10.1016/j.paid.2016.03.012>
- Krupić D., & Dinić, B. (2017). Situational cues trigger Risk assessment, Fight, Flight, but not Freeze in Blanchard's threat scenarios. *Human Ethology Bulletin* *32*(2), 14—23. <https://doi.org/10.22330/heh/322/014-023>
- Krupić, D., Gračanin, A., & Corr, P. J. (2016). The evolution of the Behavioural Approach System (BAS): Cooperative and competitive resource acquisition strategies. *Personality and Individual Differences*, *94*, 223–227. <http://doi.org/10.1016/j.paid.2016.01.044>
- Krupić, D., Križanić, V., & Corr, P. J. (2016). Personality and defensive behaviour: A factor analytic approach to threat scenario choices. *Personality and Individual Differences*, *94*,

- 303–308. <http://doi.org/10.1016/j.paid.2016.01.045>
- Lardi, C., Billieux, J., d’Acromont, M., & Linden, M. Van Der. (2008). A French adaptation of a short version of the Sensitivity to Punishment and Sensitivity to Reward Questionnaire (SPSRQ). *Personality and Individual Differences, 45*(8), 722–725. <http://doi.org/10.1016/j.paid.2008.07.019>
- Manson, J. H. (2015). Life history strategy and the HEXACO personality dimensions. *Evolutionary Psychology, 13*(1), 48–66.
- McNaughton, N. (1982). Gray’s Neuropsychology of anxiety: An enquiry into the functions of septohippocampal theories. *Behavioral and Brain Sciences, 5*(3), 492. <http://doi.org/10.1017/S0140525X00013170>
- McNaughton, N., & Corr, P. J. (2004). A two-dimensional neuropsychology of defense: fear/anxiety and defensive distance. *Neuroscience and Biobehavioral Reviews, 28*(3), 285–305. <http://doi.org/10.1016/j.neubiorev.2004.03.005>
- McNaughton, N., & Corr, P. J. (2008). The neuropsychology of fear and anxiety: A foundation for Reinforcement Sensitivity Theory. In P.J. Corr (Ed.), *The Reinforcement Sensitivity Theory of Personality*, (pp. 44–94): Cambridge, Cambridge University Press. doi:10.1017/CBO9780511819384.003
- Mehta, P. H., & Josephs, R. A. (2010). Testosterone and cortisol jointly regulate dominance: Evidence for a dual-hormone hypothesis. *Hormones and Behavior, 58*(5), 898–906. <http://doi.org/10.1016/j.yhbeh.2010.08.020>
- Meyer, B., Johnson, S. L., & Winters, R. (2001). Responsiveness to threat and incentive in bipolar disorder: Relations of the BIS/BAS Scales with symptoms. *Journal of Psychopathology and Behavioral Assessment, 23*(3), 133–143. <http://doi.org/10.1023/A:1010929402770>
- Miyazaki, K., Miyazaki, K. W., & Doya, K. (2011). Activation of dorsal raphe serotonin neurons underlies waiting for delayed rewards. *The Journal of Neuroscience, 31*(2), 469–479. <http://doi.org/10.1523/JNEUROSCI.3714-10.2011>
- Montoya, E. R., Terburg, D., Bos, P. A., & van Honk, J. (2012). Testosterone, cortisol, and serotonin as key regulators of social aggression: A review and theoretical perspective. *Motivation and Emotion, 36*(1), 65–73. <http://doi.org/10.1007/s11031-011-9264-3>
- Mouilso, E. R., Calhoun, K. S., & Rosenbloom, T. G. (2013). Impulsivity and Sexual Assault in College Men. *Violence and Victims, 28*(3), 429–442. <http://doi.org/http://dx.doi.org/10.1891/0886-6708.VV-D-12-00025>
- Panayiotou, G., Karekla, M., & Mete, I. (2014). Dispositional coping in individuals with

- anxiety disorder symptomatology: Avoidance predicts distress. *Journal of Contextual Behavioral Science*, 3(4), 314–321. <http://doi.org/10.1016/j.jcbs.2014.07.001>
- Perkins, A. M. (2016). The welfare trait: Hans Eysenck, personality and social issues. *Personality and Individual Differences*, 103, 172–178. <http://doi.org/10.1016/j.paid.2016.06.003>
- Perkins, A. (2015). *The welfare trait: How state benefits affect personality*. London, UK: Palgrave Macmillan.
- Perkins, A. M., Cooper, A., Abdelall, M., Smillie, L. D., & Corr, P. J. (2010). Personality and defensive reactions: Fear, trait anxiety, and threat magnification. *Journal of Personality*, 78(3), 1071–90. <http://doi.org/10.1111/j.1467-6494.2010.00643.x>
- Perkins, A. M., & Corr, P. J. (2006). Reactions to threat and personality: Psychometric differentiation of intensity and direction dimensions of human defensive behaviour. *Behavioural Brain Research*, 169(1), 21–28. <http://doi.org/10.1016/j.bbr.2005.11.027>
- Perkins, A. M., Leonard, A. M., Weaver, K., Dalton, J. a, Mehta, M. a, Kumari, V., ... Ettinger, U. (2013). A dose of ruthlessness: interpersonal moral judgment is hardened by the anti-anxiety drug lorazepam. *Journal of Experimental Psychology. General*, 142(3), 612–620. <http://doi.org/10.1037/a0030256>
- Pickering, A. D., & Gray, J. A. (1999). Dopamine, appetitive reinforcement, and the neuropsychology of human learning: An individual differences approach. A. Eliaz & A. Angleitner, *Advances in Research on Temperament*, (pp. 113–149). Lengerich, Germany: PABST Science Publishers.
- Pickering, A. D., & Smillie, L. D. (2008). The behavioural activation system: Challenges and opportunities. In P.J. Corr (Ed.), *The Reinforcement Sensitivity Theory of Personality*, (pp. 120–154): Cambridge, Cambridge University Press.
- Podsakoff, P. M., MacKenzie, S. B., Lee, J.-Y., & Podsakoff, N. P. (2003). Common method biases in behavioral research: a critical review of the literature and recommended remedies. *The Journal of Applied Psychology*, 88(5), 879–903. <http://doi.org/10.1037/0021-9010.88.5.879>
- Réale, D., Garant, D., Humphries, M. M., Bergeron, P., Careau, V., & Montiglio, P. O. (2010). Personality and the emergence of the pace-of-life syndrome concept at the population level. *Philosophical Transactions of the Royal Society of London. Series B, Biological Sciences*, 365(1560), 4051–4063. <http://doi.org/10.1098/rstb.2010.0208>
- Reuter, M., Cooper, A. J., Smillie, L. D., Markett, S., & Montag, C. (2015). A new measure for the revised reinforcement sensitivity theory: Psychometric criteria and genetic

- validation. *Frontiers in Systems Neuroscience*, 9, 1–38.
<http://doi.org/10.3389/fnsys.2015.00038>
- Revelle, W., Wilt, J., & Condon, D. M. (2013). Individual differences and differential psychology: A brief history and prospect. In T. Chamorro-Premuzic, A. Furnham, & S. von Stumm (Eds.) *The Wiley-Blackwell Handbook of Individual Differences* (pp. 1–38). Chichester, West Sussex, Malden, MA: Wiley-Blackwell.
<http://doi.org/10.1002/9781444343120.ch1>
- Ruch, W. (1992). Pavlov's types of nervous system, Eysenck's typology and the Hippocrates-Galen temperaments: An empirical examination of the asserted correspondence of three temperament typologies. *Personality and Individual Differences*, 13(12), 1259–1271.
[http://doi.org/10.1016/0191-8869\(92\)90168-O](http://doi.org/10.1016/0191-8869(92)90168-O)
- Sapienza, P., Zingales, L., & Maestripieri, D. (2009). Gender differences in financial risk aversion and career choices are affected by testosterone. *Proceedings of the National Academy of Sciences of the United States of America*, 106(36), 15268–15273.
<http://doi.org/10.1073/pnas.0907352106>
- Sava, F. A., & Sperneac, A. M. (2006). Sensitivity to reward and sensitivity to punishment rating scales: A validation study on the Romanian population. *Personality and Individual Differences*, 41(8), 1445–1456. <http://doi.org/10.1016/j.paid.2006.04.024>
- Schaufeli, W. B., Shimazu, A., & Taris, T. W. (2009). Being driven to work excessively hard: The evaluation of a two-factor measure of workaholism in the Netherlands and Japan. *Cross-Cultural Research*, 43(4), 320–348. <http://doi.org/10.1177/1069397109337239>
- Schmidt, N. B., Richey, J. A., Zvolensky, M. J., & Maner, J. K. (2008). Exploring human freeze responses to a threat stressor. *Journal of Behavior Therapy and Experimental Psychiatry*, 39(3), 292–304. <http://doi.org/10.1016/j.jbtep.2007.08.002>
- Scholten, M. R. M., van Honk, J., Aleman, A., & Kahn, R. S. (2006). Behavioral inhibition system (BIS), Behavioral activation system (BAS) and schizophrenia: Relationship with psychopathology and physiology. *Journal of Psychiatric Research*, 40(7), 638–645.
<http://doi.org/10.1016/j.jpsychires.2006.03.005>
- Schweighofer, N., Bertin, M., Shishida, K., Okamoto, Y., Tanaka, S. C., Yamawaki, S., & Doya, K. (2008). Low-serotonin levels increase delayed reward discounting in humans. *The Journal of Neuroscience*, 28(17), 4528–4532.
<http://doi.org/10.1523/JNEUROSCI.4982-07.2008>
- Segarra, P., Poy, R., López, R., & Moltó, J. (2014). Characterizing Carver and White's BIS/BAS subscales using the Five Factor Model of personality. *Personality and*

- Individual Differences*, 61, 18-23. doi:10.1016/j.paid.2013.12.027.
- Sellers, J. G., Mehl, M. R., & Josephs, R. A. (2007). Hormones and personality: Testosterone as a marker of individual differences. *Journal of Research in Personality*, 41(1), 126–138. <http://doi.org/10.1016/j.jrp.2006.02.004>
- Senko, C., Hulleman, C. S., & Harackiewicz, J. M. (2011). Achievement goal theory at the crossroads: Old controversies, current challenges, and new directions. *Educational Psychologist*, 46(1), 26–47. <http://doi.org/10.1080/00461520.2011.538646>
- Sideridis, G. D., & Kaplan, A. (2011). Achievement goals and persistence across tasks: The roles of failure and success. *The Journal of Experimental Education*, 79(4), 429–451. <http://doi.org/10.1080/00220973.2010.539634>
- Smederevac, S., Mitrović, D., Čolović, P., & Nikolašević, Ž. (2014). Validation of the measure of revised reinforcement sensitivity theory constructs. *Journal of Individual Differences*, 35(1), 12–21. <http://doi.org/10.1027/1614-0001/a000121>
- Smillie, L. D., Jackson, C. J., & Dalgleish, L. I. (2006). Conceptual distinctions among Carver and White's (1994) BAS scales: A reward-reactivity versus trait impulsivity perspective. *Personality and Individual Differences*, 40(5), 1039–1050. <http://doi.org/10.1016/j.paid.2005.10.012>
- Smillie, L. D., Pickering, A. D., & Jackson, C. J. (2006). The new reinforcement sensitivity theory: Implications for personality measurement. *Personality and Social Psychology Review: An Official Journal of the Society for Personality and Social Psychology, Inc*, 10(4), 320–335. http://doi.org/10.1207/s15327957pspr1004_3
- Smits, D. J. M., & Boeck, P. D. (2006). From BIS/BAS to the big five. *European Journal of Personality*, 20(4), 255–270. <http://doi.org/10.1002/per.583>
- Stelmack, R. M., & Stalikas, A. (1991). Galen and the humour theory of temperament. *Personality and Individual Differences*, 12(3), 255–263. [http://doi.org/10.1016/0191-8869\(91\)90111-N](http://doi.org/10.1016/0191-8869(91)90111-N)
- Strelau, J. (2002). *Temperament: A psychological perspective*. New York: Plenum Press. <http://doi.org/10.1017/CBO9781107415324.004>
- Torrubia, R., Ávila, C., Caseras, X. (2008). Reinforcement sensitivity scales. In P. J. Corr (Ed), *The reinforcement sensitivity theory and personality* (pp. 188-227). Cambridge: Cambridge University Press.
- Torrubia, R., Ávila, C., Moltó, J., & Caseras, X. (2001). The Sensitivity to Punishment and Sensitivity to Reward Questionnaire (SPSRQ) as a measure of Gray's anxiety and impulsivity dimensions. *Personality and Individual Differences*, 31(6), 837–862.

[http://doi.org/10.1016/S0191-8869\(00\)00183-5](http://doi.org/10.1016/S0191-8869(00)00183-5)

- Tremblay, L. K., Naranjo, C. A., Graham, S. J., Herrmann, N., Mayberg, H. S., Hevenor, S. J., & Busto, U. E. (2005). Functional neuroanatomical substrates of altered reward processing in major depressive disorder revealed by a dopaminergic probe. *Archives of General Psychiatry*, *62*(11), 1228–36. <http://doi.org/10.1001/archpsyc.62.11.1228>
- Van Vugt, M., De Cremer, D., & Janssen, D. P. (2007). Gender differences in cooperation and competition: The male-warrior hypothesis. *Psychological Science*, *18*(1), 19–23. <http://doi.org/10.1111/j.1467-9280.2007.01842.x>
- Watson, D., Clark, L. a, & Tellegen, a. (1988). Development and validation of brief measures of positive and negative affect: the PANAS scales. *Journal of Personality and Social Psychology*, *54*(6), 1063–1070. Retrieved from <http://www.ncbi.nlm.nih.gov/pubmed/3397865>
- Wilson, G. D., Barrett, P. T., & Gray, J. A. (1989). Human reactions to reward and punishment: A questionnaire examination of Gray’s personality theory. *British Journal of Psychology* *80*(4), 509-515.
- Wise, R. A. (2008). Dopamine and reward: The anhedonia hypothesis 30 years on. *Neurotoxicity Research*, *14*(2–3), 169–183. <http://doi.org/10.1007/BF03033808>
- Wolf, M., van Doorn, G. S., Leimar, O., & Weissing, F. J. (2007). Life-history trade-offs favour the evolution of animal personalities. *Nature*, *447*(7144), 581–584. <http://doi.org/10.1038/nature05835>
- Wundt, W. (1897). An outline of psychology. *Science*, *5*(127), 882–884.
- Zuckerman, M. (2007). The sensation seeking scale V (SSS-V): Still reliable and valid. *Personality and Individual Differences*, *43*(5), 1303–1305. <http://doi.org/10.1016/j.paid.2007.03.021>

5

List of tables

5. LIST OF TABLES

<i>Table 1. Operationalisations of the BAS scales in the six frequently used RST questionnaires</i>	20
<i>Table 2. Operationalisation of the BIS scales in six RST questionnaires</i>	21
<i>Table 3. Summary of the key findings in Krupić, Corr, et al., (2016) showing the congruence of the scales from the five RST questionnaires</i>	24
<i>Table 4. Redefinition of classification of the BAS scales</i>	37

6

List of figures

6. LIST OF FIGURES

Figure 1. Wundt's coordinates explaining Hippocrates-Galen typology of temperament	3
Figure 2. Eysenck's theory explaining extraversion and neuroticism by sensitivity to punishment (black column) and reward (white column)	4
Figure 3. Dynamics of RST dimensions.	8
Figure 4. Theory driven model of RST	15
Figure 5. The CFA model of the five RST questionnaires.....	27
Figure 6. The dynamic model of the multidimensional BAS	41

7

Appendix

7. APPENDIX

- Krupić, D., Corr, P.J., Ručević, S., Križanić, V., & Gračanin, A. (2016). Five Reinforcement sensitivity theory (RST) of personality questionnaires: Comparison, validity and generalization. *Personality and Individual Differences*, *97*, 19–24.
[doi:10.1016/j.paid.2016.03.012](https://doi.org/10.1016/j.paid.2016.03.012)
- Krupić, D., Križanić, V., Corr, P.J. (2016). Personality and defensive behaviour: A factor analytic approach to threat scenario choices. *Personality and Individual Differences*, *94*, 303-308. [doi:10.1016/j.paid.2016.01.045](https://doi.org/10.1016/j.paid.2016.01.045)
- Krupić, D., Corr, P.J. (2014). Individual differences in emotion induction in university examinations. *Personality and Individual Differences*, *71*, 176-180.
[doi:10.1016/j.paid.2014.08.001](https://doi.org/10.1016/j.paid.2014.08.001)
- Krupić, D. (2017). High BAS and low BIS in overconfidence, and their impact on motivation and self-efficacy after feedback. *Primenjena psihologija*. *10*(3), 297-312.
<https://doi.org/10.19090/pp.2017.3.297-312>.
- Krupić, D., Gračanin, A., & Corr, P.J. (2016). The evolution of the Behavioural Approach System (BAS): Cooperative and competitive resource acquisition strategies. *Personality and Individual Differences*, *94*, 223-227. [doi:10.1016/j.paid.2016.01.044](https://doi.org/10.1016/j.paid.2016.01.044)
- Krupić, D., Banai, B., Corr, P. J. (2017). Slow and fast BAS: Interpretation of the behavioural approach system (BAS) within Life History Theory. *Journal of Individual Differences*. *Submitted*.

7.1

Five reinforcement sensitivity theory (RST) of personality questionnaires: Comparison, validity and generalization

Krupić, D., Corr, P.J., Ručević, S., Križanić, V., & Gračanin, A.
(2016).

Personality and Individual Differences, 97, 19–24.

7.1. Five reinforcement sensitivity theory (RST) of personality questionnaires: Comparison, validity and generalization

Abstract

There are six purpose-built Reinforcement Sensitivity Theory (RST) personality questionnaires currently in use as a measure of the fight-flight-freeze system (FFFS), the behavioural inhibition system (BIS), and the behavioural approach system (BAS). They differ in their conceptualizations and operational constructs, and this poses a problem for their differential validity and the generalizability of results, and comparison of results from different studies. This paper examined the psychometric properties of five of these RST questionnaires, with a total sample of 821 participants, taken from the factor structures for the Croatian translations of BIS/BAS scales, SPSRQ, Jackson-5, RSQ and RST-PQ. Data were analysed by correlational and confirmatory factor analyses. We found some of these questionnaires achieved marginal to adequate fit indices, and they showed ambiguity in terms of convergent validity for all three general behavioural systems. These findings highlight the difficulties with generalization and comparison of results with the use of different RST questionnaires. Based on these findings, as well as the ongoing debate concerning how best to measure RST constructs, we provide information on how to interpret results from the studies conducted with different RST scales.

Keywords: Reinforcement sensitivity theory Exploratory and confirmatory factor analysis Generalizability

1. Introduction

Reinforcement sensitivity theory (RST) provides a neuropsychological account of the major systems that underlie personality, namely, the Behavioural Approach System (BAS), and two defensive systems, the Behavioural Inhibition System (BIS) and the Fight-Flight-Freeze System (FFFS) (Corr, 2008). The BAS mediates reactions to reward and non-punishment. Its outputs are positive emotions, the motivation to approach biological reinforcers, and to engage in activities that lead to consummatory behaviour (Gray & McNaughton, 2003). The FFFS is

responsible for the active avoidance and escape from aversive stimuli, while the BIS is responsible for passive avoidance and the detection and resolution of goal-conflict. In its long history, RST has encouraged the development of a number of different questionnaires (for a summary, see Torrubia, Ávila, & Caseras, 2008; Corr, 2016). In the last six years alone, three new questionnaires have been developed: the Jackson 5 (J5; Jackson, 2009), Reinforcement Sensitivity Theory Personality Questionnaire (RST-PQ; Corr & Cooper, 2016), and the Reinforcement Sensitivity Questionnaire (RSQ; Smederevac, Mitrović, Čolović, & Nikolašević, 2014). In fact, more recently, there is a fourth revised RST questionnaire (Reuter, Cooper, Smillie, Markett, & Montag, 2015), which we do not discuss further because it postdates the collection of data reported in this paper. Together with two of the most frequently used questionnaires – BIS/BAS Scales (Carver & White, 1994) and Sensitivity to Punishment and Sensitivity to Reward Questionnaire (SPSRQ; Torrubia, Avila, Moltó, & Caseras, 2001) – there are now six personality questionnaires that compete to provide a viable operational account of RST's three major neuropsychological systems.

When planning a study within RST, researchers have to choose among competing RST questionnaires. This raises question: do the results of the study depend on choice of the questionnaire? At present, there is a lack of empirical work examining the structural and psychometric properties of these questionnaires. This study aims to remedy this state of affairs.

1.1. RST questionnaires

The most widely used RST questionnaire, the BIS/BAS Scales (Carver & White, 1994), was designed upon original (unrevised) RST (Gray, 1982). This scale has several shortcomings within the context of revised RST (Corr, 2016; Corr & McNaughton, 2008, 2012; McNaughton & Corr, 2008). It emphasized the BIS and BAS, and did not differentiate the FFFS as a separate system of personality (although items capturing variance associated with the FFFS are scattered across the BIS scale, and can be separated from it; Corr & McNaughton, 2008).

SPSRQ was also developed upon original RST. It contains Sensitivity to Punishment (SP) and Sensitivity to Reward (SR) scales. Several studies show problematic psychometric properties of the translated versions of this questionnaire. In order to achieve a two-factor structure, many re-searchers have had to adjust translated versions by excluding items. In this way, the original Spanish version contains 48 items (Torrubia, Avila, Moltó, & Caseras, 2001), French version 35 (Lardi, Billieux, d'Acremont, Van Linden, 2008), and English 39 (Cogswell,

Alloy, van Dulmen, & Fresco, 2006); and, without excluding items, the Romanian version has a three-factor solution (Sava & Sperneac, 2006) – in addition to sensitivity to reward and punishment, there was a BAS ‘financial’ factor relating to earning money but this was correlated 0.67 with the Reward factor. Aluja and Blanch (2011) developed a short version of SPSRQ (SPSRQ-20) in order to enhance its psychometric properties. Besides problems of construct validity, the main issue with this questionnaire is that it is based upon the original version of RST, where impulsivity is assumed to be the underlying trait of the BAS. Several studies suggest that extraversion, rather than impulsivity, should be considered as underlying the BAS dimension (Depue & Collins, 1999; Smillie, Pickering, & Jackson, 2006). For this reason, the clearest statistical difference between BIS/BAS Scales and SPSRQ is found between BAS subscales and SR.

One of the recent RST questionnaires, J5 (Jackson, 2009) contains five scales: BAS, BIS, Fight, Flight, and Freezing. The author's validation data of this questionnaire show some theoretically ambiguous results. First, the BAS and BIS correlate positively – this is not surprising given that some of the ‘BIS’ items seem to have a definite BAS flavour reflecting social comparison or competition (item example “I aim to do better than my peers”). Second, the Fight scale is not correlated with the putative FFFS-related Flight and Freezing scales, which makes forming a unidimensional FFFS scale inappropriate. However, this result is consistent with evidence that fight and aggression (both reactive and proactive) are related to the BAS (for more detail see Corr, 2013, 2016; Corr & Cooper, 2016).

The shortcomings of these RST questionnaires motivated other authors to develop new, and preferably better, ones. RSQ (Smederevac et al., 2014) contains five scales, the same as J5. In contrast, it shows more theoretically congruent BIS and FFFS scales, but shares the same problem of Fight scale with J5. Finally, RST-PQ (Corr & Cooper, 2016) has six scales: BAS (with four subscales), BIS and FFFS, accompanied by a seventh separate measure of Defensive Fight. The four BAS sub-scales are Reward Interest, Goal-Drive Persistence, Reward reactivity, and Impulsivity. The RST-PQ was specifically modelled on revised RST, taking into account previous findings concerning the problematic (i.e., cross-loading) nature of Fight with the BAS. Item examples of the questionnaires can be found in Supplementary material.

The key assumption for a valid RST questionnaire is that the scale scores should reflect stable individual differences in activity of the brain behavioural circuits responsible for approach and avoidance motivation (e.g. Tal Gonen, Pearlson, & Hendler, 2014). When comparing the criterion validity of the questionnaires, the BIS/BAS Scales and SPSRQ had been widely studied, while newer psychometric measures, particularly RST-PQ and RSQ,

awaits for more extensive validation. Studies have related the BAS with higher activity on the left frontal cortex (e.g. Amodio, Master, Yee, & Taylor, 2008; Harmon-Jones & Allen, 1997), and the BIS with septo-hippocampal circuits (e.g. Gray & McNaughton, 2003; Levita et al., 2014). For the sake of continuity of the research within RST, it is important to establish the relations between new RST questionnaires with the earlier ones. In other words, it is important to establish the convergent validity of the new RST questionnaires with the BIS/BAS Scales and SPSRQ.

Available data on convergent validity of the RST questionnaires are limited to comparison of two questionnaires (e.g. Caci, Deschaux, & Baylé, 2007; Cogswell et al., 2006; Davis et al., 2007; Dufey, Fernández, & Mourgues, 2011; Knyazev, Slobodskaya, & Wilson, 2004; Krupić & Corr, 2014; Sava & Sperneac, 2006; Smillie, Jackson, & Dalgleish, 2006; Wallace, Malterer, & Newman, 2009), or three questionnaires (Caseras, Avila, & Torrubia, 2003; Smederevac et al., 2014; Smillie & Jackson, 2005). Authors of recent RST questionnaires provide most of the development and validation data within their publications, but there has been a noticeable absence of any attempt to provide convergent validation evidence with all of them in the same study - this is the purpose of this study.

Four models will be tested. In the first model, labelled the BAS, BIS and FFFS (see Fig. 1), the approach dimension should be constituted by BAS scales and subscales, one (passive) avoidance dimension should be constituted by BIS scales, and finally, another (active) avoidance dimension should be constituted by (Defensive) Fight, Flight, and Freezing scales. Corr (2013) has outlined difficulties in measuring defensive fight by self-report measures. He argues that language may not be adequate to capture fine conceptual differences between instrumental and defensive aggression. Thus, the second model, labelled the BAS, BIS, Flight/Freeze, will test the three-factor solution without fight scales from RST-PQ, J5 and RSQ. Third model (the BAS, BIS, Flight/Freeze, and a separate Fight) will test a four-factor structure, where the Fight factor will be added along with the three factors from the previous model. Finally, Corr (2008, 2013, 2016) has outlined the importance of the BAS sub-goal processes: (a) identification of the biological reinforcer; (b) planning behaviour; (c) executing the plan; and (d) Reward reactivity. Thus, the fourth model will test the model assuming the four RST-PQ BAS subscales, BIS, Flight/Freeze and Fight model.

2. Method

2.1. Participant and materials

An online-sample of 821 participants (415 males), $M_{AGE} = 22.31$, $SD = 4.16$ (age range from 16 to 54) completed five RST questionnaires, which were translated into the Croatian language using double-blind translation procedure. Psychology students helped in recruitment of the participants in exchange for course credits.

2.2. Measures

The BIS/BAS Scales (Carver & White, 1994) contains 24 items that form the BIS scale (7 items), and three subscales related to BAS functioning: Drive (4 items), Fun Seeking (4 items) and Reward reactivity (5 items), along with four filler items. Items were answered on four-point Likert type scale (1 — very false for me, 4 — very true for me).

SPSRQ-20 (Aluja & Blanch, 2011) is short 20-item version of SPSRQ (Torrubia et al., 2001) containing two 10-items scales: the Sensitivity to Punishment (SP) and the Sensitivity to Reward (SR) with yes/no response format.

The Jackson-5 contains 30 items, equally distributed across five scales: BAS, BIS, Fight, Flight and Freezing. The answer format is a 5-point Likert-type scale (1 = completely disagree; 5 = completely agree).

The RSQ (Smederevac et al., 2014) questionnaire has 29 items distributed across five scales, namely: BAS (6 items), BIS (7 items), Fight (6 items), Flight (5 items) and Freezing (5 items). The response format is 4-point Likert scale (1— Completely disagree; 2 — Somewhat disagree; 3 — Somewhat agree; 4 — Completely agree).

Finally, the RST-PQ (Corr & Cooper, 2016) contains 73 items that comprise five scales: BAS (32 items), BIS (23 items), Flight-Freeze System (FFS 10 items), and Defensive Fight (8 items). RST-PQ defines BAS as a multidimensional construct: Reward Interest (7 items), Goal-Drive Persistence (7 items), Reward reactivity (10 items), and Impulsivity (8 items). Items are answered on four-point Likert-type scale (“How accurately does each statement describe you?” 1 = Not at all; 4 = Highly).

All questionnaires were previously validated and used in Croatian language (e.g. Križanić, Greblo, & Knezović, 2015).

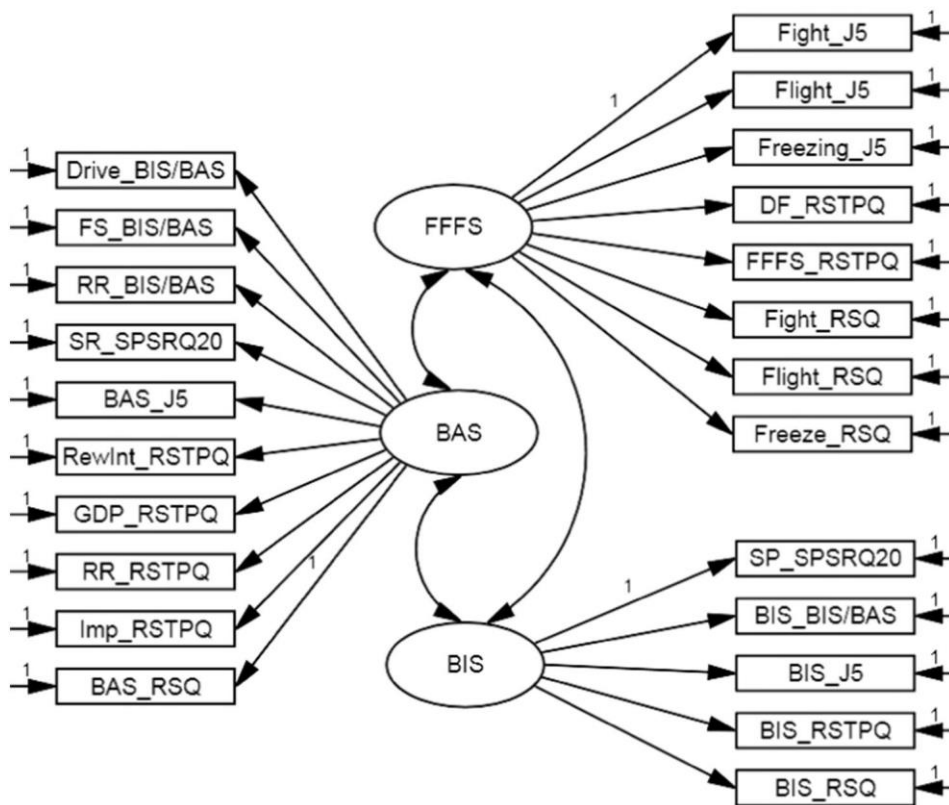

Fig. 1. Theory-driven RST model 1. Note; BIS/BAS – BIS/BAS scales; J5 – Jackson 5 questionnaire; RST-PQ- Reinforcement Sensitivity Theory Personality Questionnaire; RSQ – Reinforcement Sensitivity Questionnaire; SPSRQ20 – Sensitivity to Punishment Sensitivity to Reward Questionnaire – 20; DF – Defensive fight; SP – Sensitivity to punishment; SR - Sensitivity to reward; FS – Fun seeking; RR_BIS/BAS - Reward responsiveness; RewInt – Reward Interest; GDP – Goal-Drive Persistence; RR_RSTPQ – Reward reactivity; Imp – Impulsivity.

2.3. Data analytic plan

We tested the internal factor structure of the questionnaires by confirmatory factor analysis (CFA) using polychoric correlation matrices with Maximum Likelihood (ML) estimates method by EQS 6.1, while convergent validity by IBM SPSS Amos 18. As model fit indices, we used: (a) Sattora-Bentler scaled chi-square (χ^2) (Bentler, 2006; Sattorra & Bentler, 2001); (b) the root mean squared error of approximation (RMSEA; Steiger, 2000), where values of b.05 were taken as good fit, .05–.08 as moderate fit, .08–.10 as marginal fit and N.10 as poor fit (Hu & Bentler, 1999); and (c) the comparative fit index (CFI) were values between .90 and .95

indicated acceptable fit, and values above .95 indicated good fit (Hu & Bentler, 1999). In analyses that compare several alternative non-nested models, we report the Akaike information criterion (AIC) where the best model minimizes the value of the AIC (Akaike, 1987).

3. Results

Cronbach's alpha coefficients and correlations between all scales can be found in Supplementary materials. Cronbach alpha coefficients were in the range of .61 to .93. Out of 23 scales, five had reliability coefficients below .70, namely Fun Seeking, SPSRQ-SR, RSQ-Flight, and RST-PQ Impulsivity and Defensive fight. Table 1 displays adequate goodness of fit indices for all questionnaires in the study. We tested only the models of the questionnaires from their validity papers.

CFA yielded a very poor goodness of fit for the first three theory driven models assuming one BAS latent factor (Table 1). In order to detect statistical and potential conceptual differences between questionnaires, we have proceeded with an exploratory approach. Regarding the most recently published RST questionnaire, the RST-PQ (Corr & Cooper, 2016), we tested the model that differentiates four separate the BAS scales (Fig. 2). According to available data provided in Corr and Cooper (2016) and content validity of the scales, we detected similarities in operational definitions of the BAS between; (a) Reward Interest, BAS-RSQ and BAS-J5; (b) Goal-Drive Persistence and Drive; (c) Reward reactivity and Reward Responsiveness; (d) SR, Fun Seeking and Impulsivity. These four latent variables were labelled as BAS-Wanting, BAS-Striving, BAS-Liking and BAS-Capture, respectively. Along with these four BAS latent variables, the BIS, Flight/Freeze and Fight latent variables are entered in the model. The goodness of fit has been significantly improved in compare to the models with the unidimensional BAS latent variable. In addition, to achieve better fit indices of the model, we tested the model without the SR, and one without Fun Seeking. The results show that the best fit indices are achieved with the model without Fun Seeking. Data presented in the Fig. 2. shows that all scales are well saturated in the model, except some-what lower saturated the SR. For the better readability of the results, correlations between the latent variables from the Fig. 2 are represented in the Table 2. The BAS latent variables are highly intercorrelated, ranging from $r = .64$ to $.85$. Notwithstanding the high correlations, they show different correlational pattern with avoidance scales, which evidences their divergent validity. The BAS-Wanting and BAS-Striving correlates negatively, the BAS-Liking positively, and the BAS-Capture do not

correlates with the BIS and Flight/Freeze factors. Further, the BAS-Capture highly correlates with Fight, while the rest of the BAS factors correlated moderately. The Fight factor do not correlate with the BIS, and correlate negatively with the Flight/Freeze factors. These results show the discrepancy between the theoretical and operational definition of the construct. Finally, the BIS and Flight/ Freeze were highly correlated ($r = .85$).

Table 1

Goodness of fit indices for BIS/BAS, SPSRQ-20, Jackson-5, RST-PQ and RSQ and for theory-driven models for assessing convergent validity.

	χ^2 (df)	CFI	RMSEA	AIC
Questionnaire				
BIS/BAS Scales (Carver & White, 1994)	592.03 (164)	.949	.056	–
SPSRQ-20 (Aluja & Blanch, 2011)	386.89 (169)	.944	.040	–
Jackson 5 (Jackson, 2009)	1519.45 (395)	.931	.059	–
RSQ (Smederevac et al., 2014)	1198.70 (367)	.946	.053	–
RST-PQ (Corr & Cooper, 2016)	6898.90 (2000)	.931	.055	–
Models				
The BAS, BIS and FFFS	4737.90 (227)	.82	.156	4283.90
The BAS, BIS, Flight/Freeze and separate Fight	2724.81 (203)	.90	.123	2318.08
The BAS, BIS and Flight/Freeze	2377.82 (203)	.91	.114	1971.82
The BAS higher order, BIS, Flight/Freeze and Fight	1594.78 (176)	.86	.099	1704.78
Four separate the BAS subscales, BIS, Flight/Freeze and Fight	1376.42 (185)	.89	.089	1512.42
Four separate the BAS subscales, BIS, Flight/Freeze and Fight (-SR)	1254.54 (165)	.90	.090	1386.54
Four separate the BAS subscales, BIS, Flight/Freeze and Fight (-FS)	1168.19 (165)	.90	.086	1300.19

Table 2

Correlational matrix of the latent variables from the model of the RST questionnaires.

	BAS striving	BAS liking	BAS capture	BIS	Fight	Flight/Freeze
BAS wanting	.76	.64	.85	-.40	.33	-.33
BAS striving		.80	.73	-.16	.36	-.08
BAS liking			.77	.17	.34	.18
BAS capture				.03	.80	.04
BIS					.01	.85
Fight						-.11

4. Discussion

We had two main aims in this paper. First, examination of the factor structure for all RST questionnaires. The CFA results showed adequate model fit for all RST questionnaires used in this study. These results are generally congruent with previous validation studies (Aluja & Blanch, 2011; Carver & White, 1994; Corr & Cooper, 2016; Jackson, 2009; Smederevac et al., 2014). The second, and major aim of the paper concerns convergent validity of all RST questionnaires. Overall data indicate certain problems with generalization of the studies conducted with various RST questionnaires. The results of this study for convergent validity of RST questionnaires are the first to show complex relation between all the questionnaires currently in use. This opens space to discuss on some unresolved RST psychometrical issues.

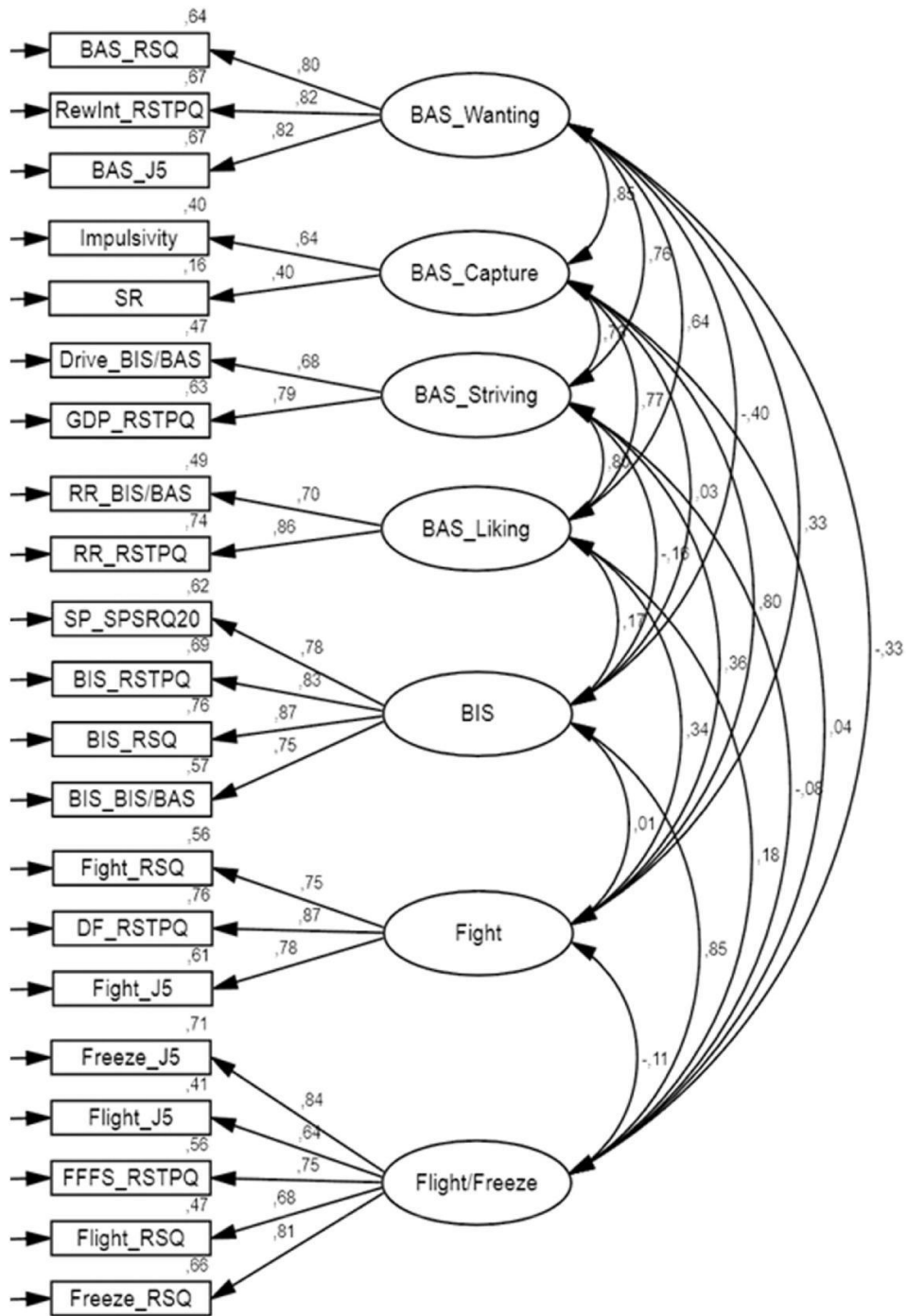

Fig. 2. The final model consisted of the five RST questionnaires.

4.1. Whether the BAS can be studied as unidimensional construct?

None of the models assuming one BAS latent variable achieved an adequate fit indices. The confirmation of the alternative models that recognises the differences between the BAS scales suggests not to use the BAS as a unidimensional construct, which can be frequently found in studies conducted with the BIS/BAS Scales. Moreover, this is especially relevant due to differences in correlation between the four BAS factors and the avoidance scales that may lead to different conclusion in the studies conducted with different RST questionnaires.

Diversity of the BAS scales presents a challenge in further development of RST, and the nature of their differences are yet to be established. The theory should be able to explain differences in various BAS processes and provide set of testable prediction that could explain differences in findings among different scales. Corr and Cooper (2016) provide theoretical explanation of the RST-PQ-BAS scales. Reward Interest measures identification of the biological reinforcer, Goal-Drive Persistence planning behaviour, while Impulsivity captures final execution of the plan, and Reward reactivity measures emotional reactions on receiving reward. The available data evidences the usefulness of studying the separate BAS scales (e.g. Krupić, Gračanin, & Corr, 2016).

4.2. How to interpret the findings from the previous RST studies conducted with various RST questionnaires?

In order to provide continuation of the findings from previous and future studies, it is important to detect which the BAS scales converge, and which do not. On the basis of our data, the BAS-J5 and BAS-RSQ highly converge with Reward Interest; Drive with Goal-Drive Persistence; Reward responsiveness with Reward reactivity; and, finally, Impulsivity with the SR. However, low square multiple correlations of the SR suggests more alienated operational definition from the rest of the BAS scales. Fun Seeking is the only scale that did not fit in the model. Lower convergence of Fun Seeking might result because of more narrowed content of the scales focusing on fun activities, which can be influenced by various factors such as age. Since our sample was in age range from 16 to 54, it might be that it affected the results, and decreased correlation with other the BAS scales. Taken all together, these findings may contribute to interpreting and evaluating findings of studies conducted with various RST questionnaire.

4.3. Is Fight approach or avoidance construct?

Our data show that the Fight factor represents approach rather than avoidance construct, since it correlates with BAS, not the Flight and Freeze scales. This may be due to poor operationalization of the scale or due to lack of language expressions that may provide a lack of differentiation between defensive and instrumental types of aggression (Corr, 2013). Furthermore, the fight scales do not correlate with Flight and Freeze, while these scales should represent the Fight/Flight/Freeze System. Thus, the data given with fight scales could suggest conclusions that are not congruent with the theory.

4.4. Divergence and generalisability of the BIS and Flight/Freeze scales

Notwithstanding the fact that the correlation between the BIS and Flight/Freeze latent variable is very high ($r = .85$), Krupić, Križanić, and Corr (2016) showed incremental validity of these scales in predicting defensive behaviours, which supports RST perspective of two highly correlated but still separate avoidance mechanisms (see also Corr & Cooper, 2016).

Concerning the generalizability of studies, BIS and Flight/Freeze scales showed a high level of congruence. However, although the BIS scales highly converge and they can be used interchangeable, the major exception is the BIS-J5. This is not a surprise, since the content validity of the scale is obviously different from the rest of RST questionnaires. Hence, generalizability of the studies conducted with different RST questionnaires may not be jeopardized with BIS (except BIS-J5) and Flight/Freeze and Fight scales.

There is an important conceptual point to be considered, which emerged from limitations of the study. We have not shown validity in terms of the association of these RST scales with external criteria. It would be a mistake to assume that the psychometric structure of different RST questionnaires can uncover the ‘true’ structures of RST. The most important criterion of the validity of these scales will come in the form of correlations with carefully chosen behavioural and neurophysiological data, for example, this research could entail EEG — in relation to the BIS (e.g. McNaughton, Swart, Neo, Bates, & Glue, 2013) and BAS (e.g. Cooper, Duke, Pickering, & Smillie, 2014; Gable & Harmon-Jones, 2013). What we have shown is that the different RST questionnaire measures of personality are not isomorphic with each other. However, there is a possibility that future experimental studies may cause us to revise this

conclusion. Finally, this study was conducted on questionnaires translated into Croatian, which could diminish generalizability of the findings for the RST questionnaires in other languages.

To conclude, our study indicates acceptable internal validity for all RST questionnaires, and convergent validity with few exceptions (the BIS-J5, Fun Seeking, and SR should be interpreted with caution). This reflects in a lower level of generalizability of results conducted with different questionnaires – important information in interpreting results of the studies within RST. Overall, we hope that our results summarized in Fig. 2 would help to control potential biases in the future RST studies, and to increase generalizability of the findings. Nevertheless, much work is needed to prove validity of the existing RST questionnaires.

References

- Akaike, H. (1987). Factor analysis and AIC. *Psychometrika*, *52*, 317–332. <http://dx.doi.org/10.1007/BF02294359>.
- Aluja, A., & Blanch, A. (2011). Neuropsychological behavioral inhibition system (BIS) and behavioral approach system (BAS) assessment: A shortened sensitivity to punishment and sensitivity to reward questionnaire version (SPSRQ–20). *Journal of Personality Assessment*, *93*(6), 628–636. <http://dx.doi.org/10.1080/00223891.2011.608760>.
- Amodio, D. M., Master, S. L., Yee, C. M., & Taylor, S. E. (2008). Neurocognitive components of the behavioral inhibition and activation systems: Implications for theories of self-regulation. *Psychophysiology*, *45*(1), 11–19. <http://dx.doi.org/10.1111/j.1469-8986.2007.00609.x>.
- Bentler, P. M. (2006). *EQS 6 Structural Equations Program Manual*. Encino: Multivariate Software, Inc.
- Caci, H., Deschaux, O., & Baylé, F. J. (2007). Psychometric properties of the French versions of the BIS/BAS scales and the SPSRQ. *Personality and Individual Differences*, *42*(6), 987–998. <http://dx.doi.org/10.1016/j.paid.2006.09.008>.
- Carver, C. S., & White, T. L. (1994). Behavioral inhibition, behavioral activation, and affective responses to impending reward and punishment: The BIS/BAS Scales. *Journal of Personality and Social Psychology*, *67*(2), 319–333. <http://dx.doi.org/10.1037/0022-3514.67.2.319>.
- Caseras, X., Avila, C., & Torrubia, R. (2003). The measurement of individual differences in behavioural inhibition and behavioural activation systems: A comparison of personality

- scales. *Personality and Individual Differences*, 34(6), 999–1013. [http://dx.doi.org/10.1016/S0191-8869\(02\)00084-3](http://dx.doi.org/10.1016/S0191-8869(02)00084-3).
- Cogswell, A., Alloy, L. B., van Dulmen, M. H., & Fresco, D. M. (2006). A psychometric evaluation of behavioral inhibition and approach self-report measures. *Personality and Individual Differences*, 40(8), 1649–1658. <http://dx.doi.org/10.1016/j.paid.2005.12.008>.
- Cooper, A. J., Duke, E., Pickering, A. D., & Smillie, L. D. (2014). Individual differences in re-ward prediction error: Contrasting relations between feedback related negativity and trait measures of extraversion, impulsivity and reward sensitivity. *Frontiers in Human Neuroscience*, 8, 248. <http://dx.doi.org/10.3389/fnhum.2014.00248>.
- Corr, P. J. (2008). Reinforcement sensitivity theory (RST): Introduction. In P. J. Corr (Ed.), *The Reinforcement Sensitivity Theory and Personality* (pp. 1–43). Cambridge: Cambridge University Press. <http://dx.doi.org/10.1017/CBO9780511819384.002>.
- Corr, P. J. (2013). Approach and avoidance behavior: Multiple systems and their interactions. *Emotion Review*, 5(3), 286–291. <http://dx.doi.org/10.1177/1754073913477507>.
- Corr, P. J. (2016). Reinforcement sensitivity theory of personality questionnaires: Structural survey with recommendations. *Personality and Individual Differences*, 89, 60–64. <http://dx.doi.org/10.1016/j.paid.2015.09.045>.
- Corr, P. J., & Cooper, A. (2016). The reinforcement sensitivity theory personality scales (RST-PQ): Development and validation. *Psychological Assessment*, Feb. 4, advanced online publication. <http://dx.doi.org/10.1037/pas0000273>.
- Corr, P. J., & McNaughton, N. (2008). Reinforcement sensitivity theory and personality. In P. J. Corr (Ed.), *The Reinforcement Sensitivity Theory of Personality* (pp. 155–187). Cambridge: Cambridge University Press. <http://dx.doi.org/10.1017/CBO9780511819384.006>.
- Corr, P. J., & McNaughton, N. (2012). Neuroscience and approach/avoidance personality traits: A two stage (valuation-motivation) approach. *Neuroscience and Biobehavioral Reviews*, 36(10), 2339–2354. <http://dx.doi.org/10.1016/j.neubiorev.2012.09.013>.
- Davis, C., Patte, K., Levitan, R., Reid, C., Tweed, S., & Curtis, C. (2007). From motivation to behaviour: A model of reward sensitivity, overeating, and food preferences in the risk profile for obesity. *Appetite*, 48(1), 12–19. <http://dx.doi.org/10.1016/j.appet.2006.05.016>.
- Depue, R. A., & Collins, P. F. (1999). Neurobiology of the structure of personality: Dopamine, facilitation of incentive motivation, and extraversion. *Behavioral and Brain Sciences*, 22(03), 491–517. <http://dx.doi.org/10.1017/S0140525X99002046>.

- Dufey, M., Fernández, A. M., & Mourgues, C. (2011). Assessment of the behavioral inhibition system and the behavioral approach system: Adaptation and validation of the sensitivity to punishment and sensitivity to reward questionnaire (SPSRQ) in a Chilean sample. *The Spanish Journal of Psychology*, *14*(01), 432–440. http://dx.doi.org/10.5209/rev_SJOP.2011.v14.n1.39.
- Gable, P. A., & Harmon-Jones, E. (2013). Trait behavioral approach sensitivity (BAS) relates to early (b150 ms) electrocortical responses to appetitive stimuli. *Social Cognitive and Affective Neuroscience*, *8*(7), 795–798. <http://dx.doi.org/10.1093/scan/nss072>.
- Gray, J. A. (1982). *The neuropsychology of anxiety: An investigation into the functions of the septo-hippocampal system*. Oxford, England: Oxford University Press.
- Gray, J. A., & McNaughton, N. (2003). *The Neuropsychology of anxiety: An enquiry into the function of the septo-hippocampal system* (No. 33). Oxford University Press.
- Harmon-Jones, E., & Allen, J. J. (1997). Behavioral activation sensitivity and resting frontal EEG asymmetry: Covariation of putative indicators related to risk for mood disorders. *Journal of abnormal psychology*, *106*(1), 159 – 163.
- Hu, L. T., & Bentler, P. M. (1999). Cutoff criteria for fit indexes in covariance structure analysis: Conventional criteria versus new alternatives. *Structural Equation Modeling: A Multidisciplinary Journal*, *6*(1), 1–55. <http://dx.doi.org/10.1080/10705519909540118>.
- Jackson, C. J. (2009). Jackson-5 scales of revised Reinforcement Sensitivity Theory (r-RST) and their application to dysfunctional real world outcomes. *Journal of Research in Personality*, *43*(4), 556–569. <http://dx.doi.org/10.1016/j.jrp.2009.02.007>.
- Knyazev, G. G., Slobodskaya, H. R., & Wilson, G. D. (2004). Comparison of the construct validity of the Gray–Wilson Personality questionnaire and the BIS/BAS scales. *Personality and Individual Differences*, *37*(8), 1565–1582. <http://dx.doi.org/10.1016/j.paid.2004.02.013>.
- Križanić, V., Greblo, Z., & Knezović, Z. (2015). Mjere osjetljivosti bihevioralnoga inhibicijskog i aktivacijskoga sustava kao prediktori dimenzija petofaktorskoga modela ličnosti. *Psychological Topics*, *24*(2), 305–324. (<http://hrcak.srce.hr/file/209682>).
- Krupić, D., & Corr, P. J. (2014). Individual differences in emotion elicitation in university examinations: A quasi-experimental study. *Personality and Individual Differences*, *71*, 176–180. <http://dx.doi.org/10.1016/j.paid.2014.08.001>.
- Krupić, D., Gračanin, A., & Corr, P. J. (2016). The evolution of the behavioural approach system (BAS): Cooperative and competitive resource acquisition strategies. *Personality and Individual Differences*, *94*, 223–227. <http://dx.doi.org/10.1016/j.paid.2016.01.044>.

- Krupić, D., Križanić, V., & Corr, P. J. (2016). Personality and defensive behaviour: A factor analytic approach to threat scenario choices. *Personality and Individual Differences, 94*, 303–308. <http://dx.doi.org/10.1016/j.paid.2016.01.045>.
- Lardi, C., Billieux, J., d'Acremont, M., & Van der Linden, M. (2008). A French adaptation of a short version of the sensitivity to punishment and sensitivity to reward questionnaire (SPSRQ). *Personality and Individual Differences, 45*, 722–725. <http://dx.doi.org/10.1016/j.paid.2008.07.019>.
- Levita, L., Bois, C., Healey, A., Smyllie, E., Papakonstantinou, E., Hartley, T., & Lever, C. (2014). The behavioural inhibition system, anxiety and hippocampal volume in a non-clinical population. *Biology of Mood & Anxiety Disorders, 4*(1), 1. <http://dx.doi.org/10.1186/2045-5380-4-4>.
- McNaughton, N., & Corr, P. J. (2008). The neuropsychology of fear and anxiety: A foundation for Reinforcement Sensitivity Theory. In P. J. Corr (Ed.), *The Reinforcement Sensitivity Theory of Personality* (pp. 44–94). Cambridge: Cambridge University Press. <http://dx.doi.org/10.1017/CBO9780511819384.003>.
- McNaughton, N., Swart, C., Neo, P., Bates, V., & Glue, P. (2013). Anti-anxiety drugs reduce conflict-specific “theta”: A possible human anxiety-specific biomarker. *Journal of Affective Disorders, 15*, 104–111. <http://dx.doi.org/10.1016/j.jad.2012.11.057>.
- Reuter, M., Cooper, A. J., Smillie, L. D., Markett, S., & Montag, C. (2015). A new measure for the revised reinforcement sensitivity theory: Psychometric criteria and genetic validation. *Frontiers in Systems Neuroscience, 9*, 38. <http://dx.doi.org/10.3389/fnsys.2015.00038>.
- Satorra, A., & Bentler, P. M. (2001). A scaled difference chi-square test statistic for moment structure analysis. *Psychometrika, 66*(4), 507–514. <http://dx.doi.org/10.1007/BF02296192>.
- Sava, F. A., & Sperneac, A. M. (2006). Sensitivity to reward and sensitivity to punishment rating scales: A validation study on the Romanian population. *Personality and Individual Differences, 41*(8), 1445–1456. <http://dx.doi.org/10.1016/j.paid.2006.04.024>.
- Smederevac, S., Mitrović, D., Čolović, P., & Nikolašević, Ž. (2014). Validation of the measure of revised reinforcement sensitivity theory constructs. *Journal of Individual Differences, 35*(1), 12–21. <http://dx.doi.org/10.1027/1614-0001/a000121>.
- Smillie, L. D., & Jackson, C. J. (2005). The appetitive motivation scale and other BAS measures in the prediction of approach and active avoidance. *Personality and Individual Differences, 38*(4), 981–994. <http://dx.doi.org/10.1016/j.paid.2004.09.013>.

- Smillie, L. D., Jackson, C. J., & Dalgleish, L. I. (2006a). Conceptual distinctions among Carver and White's (1994) BAS scales: A reward-reactivity versus trait impulsivity perspective. *Personality and Individual Differences, 40*(5), 1039–1050. <http://dx.doi.org/10.1016/j.paid.2005.10.012>.
- Smillie, L. D., Pickering, A. D., & Jackson, C. J. (2006b). The new reinforcement sensitivity theory: Implications for personality measurement. *Personality and Social Psychology Review, 10*(4), 320–335. http://dx.doi.org/10.1207/s15327957pspr1004_3.
- Steiger, J. H. (2000). Point estimation, hypothesis testing, and interval estimation using the RMSEA: Some comments and a reply to Hayduk and Glaser. *Structural Equation Modelling, 7*(2), 149–162. http://dx.doi.org/10.1207/S15328007SEM0702_1.
- Tal Gonen, H. S., Pearlson, G., & Hendler, T. (2014). Moods as ups and downs of the motivation pendulum: Revisiting reinforcement sensitivity theory (RST) in bipolar disorder. *Frontiers in Behavioral Neuroscience, 8*. <http://dx.doi.org/10.3389/fnbeh.2014.00378>.
- Torrubia, R., Ávila, C., & Caseras, X. (2008). Reinforcement sensitivity scales. In P. J. Corr (Ed.), *The Reinforcement Sensitivity Theory of Personality* (pp. 188–227). New York: Cambridge University Press. <http://dx.doi.org/10.1017/CBO9780511819384.007>.
- Torrubia, R., Avila, C., Moltó, J., & Caseras, X. (2001). The sensitivity to punishment and sensitivity to reward questionnaire (SPSRQ) as a measure of Gray's anxiety and impulsivity dimensions. *Personality and Individual Differences, 31*(6), 837–862. [http://dx.doi.org/10.1016/S0191-8869\(00\)00183-5](http://dx.doi.org/10.1016/S0191-8869(00)00183-5).
- Wallace, J. F., Malterer, M. B., & Newman, J. P. (2009). Mapping Gray's BIS and BAS constructs onto factor 1 and factor 2 of Hare's psychopathy checklist–revised. *Personality and Individual Differences, 47*(8), 812–816. <http://dx.doi.org/10.1016/j.paid.2009.06.019>.

7.2

Personality and defensive behaviour: A factor analytic approach to threat scenario choices

Krupić, D., Križanić, V., Corr, P.J. (2016)

Personality and Individual Differences, 94, 303-308.

7.2. Personality and defensive behaviour: A factor analytic approach to threat scenario choices

Abstract

Although people tend to react in specific ways in threatening situations, research points to the importance of individual differences in these defensive behaviours. From the perspective of reinforcement sensitivity theory (RST), this study examined the role of personality traits in defensive behaviours. Four RST questionnaires and Blanchards' threat scenarios were used, with a total of 1019 participants. The threat scenarios were modified and examined by exploratory factor analysis (EFA), while their relationship with the RST questionnaires was explored by correlational and regression analyses. The EFA revealed an orthogonal two-dimensional structure of defensive direction: defensive direction towards threat and defensive direction away from threat, while defensive intensity was not separately extracted. The results revealed that different operationalizations of the BAS, BIS and FFFS, from the various RST questionnaires, produced different associations with Blanchards' threat scenarios. In general, the BIS, Flight and Freezing scales predicted tendencies to move away from the threat, while Fight and some BAS Scales predicted tendencies to move towards the threat, in dangerous situations. These findings challenge some aspects of RST, especially their lack of association between the BIS and defensive direction towards threat. Directions for further research are indicated.

Keywords: Reinforcement sensitivity theory, Personality, Threat, Defensive behaviour

1. Introduction

Imagine you are walking alone in the street. Suddenly a man with a knife starts running in your direction. How will you react? Would you fight or flee? If there are no individual differences in defensive behaviour, all people should behave in the same manner in such a life-threatening situation. Certainly, when the influences of situations and traits are compared, the situation has the greater impact at the behavioural level (Ein-Dor & Perry-Paldi, 2014). Still, people differ in their levels of fear and anxiety, and, as shown below, these differences should

be expected to relate to differences in defensive reactions. For example, in occupational life some people have a preference for being soldiers and fire-fighters, and during leisure activities some have a preference towards dangerous hobbies such as free climbing and paragliding. Other people would not dream of engaging in these occupations or activities. In the clinical domain, people who suffer from phobic disorders can perceive even walking in a neighbourhood as a life-threatening activity. Hence it seems that, indeed, people do differ in the way they perceive and behave in potentially threatening situations.

Currently, RST is the most prominent theory explaining the role of individual differences in fear- and anxiety-related behaviours, and also approach-related behaviours. It is a neuropsychological theory of personality that assumes the existence of three emotion-motivation systems: one approach system (Behavioural Approach System, BAS); and two avoidance systems (Behavioural Inhibition System, BIS; and Fight, Flight, Freezing System, FFFS). The most distinctive features of the two avoidance systems are emotional output and defensive direction: the BIS activates behavioural repertoire when moving towards a threat, eliciting the emotional state of anxiety; while the FFFS activates behaviour that moves the individual away from the threat and elicits the emotional state of fear (Corr, 2008, 2011, 2013; Gray & McNaughton, 2000; McNaughton & Corr, 2004).

FFFS-related fear should occur in the context of much clearer danger, eliciting avoidance and escape behaviours, whereas BIS-related anxiety should occur in ambiguous threat situations, leading to risk assessment (checking out, exploration, investigation) (Blanchard, Hynd, Minke, Minemoto, & Blanchard, 2001). In the prediction of specific defensive behaviour, situational factors need to be taken into account. When a place of concealment/protection is present in a clearly dangerous situation, hiding is elicited; but, in the context of inescapable dangerous situations, two distinct defensive behaviours could be elicited: freezing or attack (defensive fight). If the source of threat is in the near spatio-temporal distance, and escape is not possible, then freezing ('playing dead') is an adaptive form of immobilization in order to evade detection. However, if spotted by the threat, then the only viable behavioural reaction is to attack the source of threat in order (a) to protect oneself and (b) escape the situation. There are now extensive experimental animal studies supporting these statements (Blanchard et al., 2001; Blanchard, Griebel, Pobbe, & Blanchard, 2011; Corr & McNaughton, 2008; Shuhama, Del-Ben, Loureiro, & Graeff, 2007).

In marked contrast to animal studies, examination of human defensive behaviour typically relies on self-report data, which is reasonable from the points of view of ethics and convenience. Although self-report methodology has limitations, it still provides an invaluable source of

information (Pappens et al., 2013). However, issues are raised concerning the compatibility of behavioural and questionnaire data, and how each set of data relates to findings from experimental animals.

The best-known self-report instrument for measuring defensive behavioural repertoire in humans was developed by Blanchard et al. (2001) on the basis of their extensive rodent studies. Twelve scenarios, presenting different threatening situations, are modelled on distance to threat and situational factors of avoidance/escapability. Additionally, ten behaviours are provided from which participants must choose to match the 12 threat scenarios: hide; freeze, immobilization; run away, try to escape; threaten to scream or call for help; yell, scream, or call for help; threaten to attack; attack or struggle; check out, approach, or investigate; look for something to use as a weapon; and beg, plead for mercy, or negotiate. Studies have indicated that threat scenarios can predict (Erber, Szuchman, & Prager, 2001) or even elicit emotional and physiological reactions (Bernat, Calhoun, & Adams, 1999; Conklin, Tiffany, & Vrana, 2000). Hence, findings suggest that they can be used as a roughly fair measure of defensive behavioural repertoire.

Previous data indicate that personality explains a significant portion of individual variances in Blanchards' threat scenarios. Perkins and Corr (2006) developed a coding system to assess defensive direction and defensive intensity (see Fig. 1). These constructs present an important way to understand individual differences in defensive behaviours (Corr & McNaughton, 2012; Gray & McNaughton, 2000; McNaughton & Corr, 2004). Defensive intensity presents a perceived spatio-temporal distance of the threat, while defensive direction presents behavioural tendencies that can be divided into direction towards or direction away from the threat. Studies have shown that anxious and fear-prone individuals have shorter defensive distance (i.e., they experience threatening stimuli as being more intense than others). In relation to personality, Spielberger's trait anxiety is associated with a tendency to orientate towards the threat (Perkins & Corr, 2006); psychoticism (tough-mindedness) negatively relates to defensive intensity; while the BIS scale positively correlates with both defensive intensity and direction (Perkins, Cooper, Abdelall, Smillie, & Corr, 2010; Perkins & Corr, 2006).

Studies showing the importance of personality in these threat scenarios pose some methodological problems and unresolved issues. First, threat scenarios provide responses at a nominal measurement level, which limits the possible range of available statistical procedures to analyse defensive behaviours. The first attempt to calculate total scores from threat scenarios came from Perkins and Corr (2006). They developed a coding system for defensive direction and distance upon theoretical assumptions of RST, but it has not yet been empirically tested by

means of exploratory factor analysis (EFA). Secondly, a recent study suggests differences in operationalization of the BIS and FFFS scales between various RST purpose-built questionnaires (Krupić, Corr, Ručević, Križanić, & Gračanin submitted for publication). Hence, both the threat scenarios and personality questionnaires deserve further empirical examination, before a relation between personality and threat scenarios can be firmly established.

The aim of this study is to test the relevance of personality traits in threat scenarios. Bearing in mind these methodological problems, the coding system will be examined, and several RST questionnaires that contain separate BIS and FFFS scales will be compared.

Psychometric examination of the coding system requires a slight methodological modification of the threat scenarios. In addition to the original procedure for the threat scenarios, five-point rating scales are provided for each of the 10 defensive behaviours for the 12 threat scenarios. This modification in procedure allows the computing of total scores for the 10 defensive behaviours across the 12 threat situations, which in addition allows closer examination by exploratory factor analysis (EFA). These results may support or suggest modifications to the operationalization of defensive intensity and defensive direction. Furthermore, administering four RST questionnaires alongside the threat scenarios allows detection of operational differences between competing questionnaires in relation to the statistically derived factors of defensive behaviour.

On the basis of previous studies, we expected to replicate past findings: (a) the BIS and FFFS correlate with defensive intensity, reflecting greater overall threat sensitivity; (b) the FFFS positively correlates with defensive direction (moving away from the source of threat); and (c) the BIS negatively correlates with defensive direction (moving towards the source of threat).

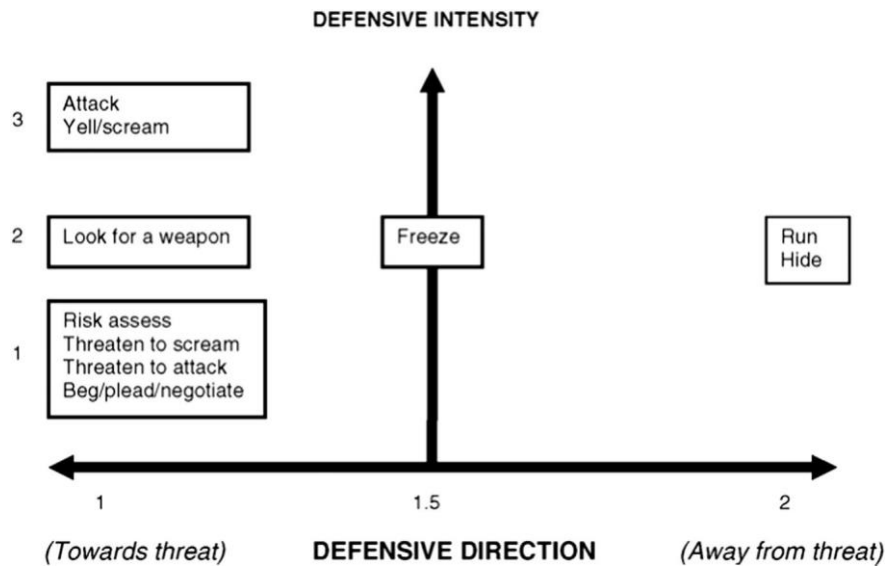

Fig. 1. Threat-scenario response choices coded for defensive intensity and defensive direction (Perkins & Corr, 2006).

2. Method

2.1. Participants and procedure

A total of 1019 participants (412 males) ranging in age from 12 to 68 ($M = 23.78$, $SD = 8.23$) completed a battery of questionnaires online via Limesurvey software.

2.2. Instruments

Threat scenarios (Blanchard et al., 2001) have been studied previously (Mesquita et al., 2011; Perkins & Corr, 2006; Perkins et al., 2010; Shuhama et al., 2007). They are designed to measure 10 defensive behaviours in 12 threatening situations. This instrument was administered using the original procedure as in Blanchard et al. (2001). Defensive behaviours were rated on a 5-point Likert-type scale. Furthermore, scores for defensive direction and defensive intensity were computed in accordance with the procedure detailed by Perkins and Corr (2006) using these formulae: Defensive intensity = (Risk assessment + Threaten to scream + Threaten to attack + Begging) + 2 × (Looking for a weapon + Freezing + Run + Hide) + 3 × (Attack +

Yell/Scream); and Defensive direction = (Risk assessment + Threaten to scream + Threaten to attack + Begging + Looking for a weapon + Attack + Yell / Scream) + 1.5 × Freezing + 2 × (Run + Hide).

All subscales computed with the modified procedure achieved Cronbach's alpha greater than .80, with defensive intensity and direction below .70, at $\alpha = .66$ and $.62$, respectively (see Table 2).

Four RST questionnaires were administered to obtain measures of the BAS, BIS and FFFS. The most widely used RST questionnaire, the 20-item BIS/BAS Scales (Carver & White, 1994) contains the BIS scale and three BAS subscales: Drive, Fun-seeking and Reward responsiveness. Later, Corr and McNaughton (2008) suggested splitting the BIS scale into BIS and FFFS scales, which is applied in this study. Items “Even if something bad is about to happen to me, I rarely experience fear or nervousness” and “I have few fears compared to my friends” formed FFFS, whereas the other five formed the BIS scale, as used in Beck, Smits, Claes, Vandereycken, and Bijttebier (2009). One of the most recent RST questionnaires, the 30-item Jackson 5 (Jackson, 2009), contains five scales: BAS, BIS, Fight, Flight and Freezing, the same as the 29-item Reinforcement Sensitivity Questionnaire (RSQ; Smederevac, Mitrović, Čolović, & Nikolašević, 2014). Finally, a 79-item version of the Reinforcement Sensitivity Theory Personality Questionnaire (RST-PQ; Corr & Cooper, 2016) was used (5 items were fillers). This has four scales: BAS (with four subscales: Reward Interest, Goal-Drive Persistence, Reward reactivity, and Impulsivity), BIS and FFFS, accompanied by a separate measure of Defensive fight. All of the four RST questionnaires are well-studied and possess adequate psychometric characteristics. All questionnaires are translated into, and validated in, the Croatian language (Krupić, et al., submitted for publication).

3. Results

The results of EFA, examining the factor structure of Blanchards' threat scenarios, are presented in Table 1, and descriptive statistics and correlations with personality questionnaires in Table 2, while correlation between four RST questionnaires can be found in Supplementary materials. The KMO measurement adequacy coefficient was $.79$. We used principal-axis factoring as a method of extraction with oblique rotation. Upon three criteria (eigenvalue greater than one, scree plot and parallel analysis) we decided for a two-factor solution that explained

59.61% of the variance. Correlation between the two axes was $r = .02$. The two factors are labelled defensive direction away from threat and defensive direction towards threat.

Table 1

Pattern matrix of defensive behaviour scales from the threat scenarios.

	Factor		h²
	Defensive direction away from threat	Defensive direction towards threat	
Yell/scream	.869	.085	.759
Threaten to scream	.849	.162	.740
Run	.795	-.167	.666
Hide	.741	.015	.549
Freezing	.694	-.231	.543
Beg/plead/negotiate	.644	.168	.437
Attack	-.028	.907	.824
Threaten to attack	.076	.876	.770
Look for a weapon	.188	.639	.438
Risk assessment	-.252	.408	.235

Loadings above 0.30 are bolded. The eigenvalue of the third, unretained, factor was 0.84. $h^2 =$ communality coefficient.

For comparability with previous studies, defensive intensity and defensive direction were computed upon the original coding system. Defensive direction away from threat and defensive direction towards threat are reliable scales, achieving a Cronbach's α reliability coefficient of .78 and .89, respectively, while defensive intensity and defensive direction have somewhat lower reliability coefficients, $\alpha = .66$ and .62, respectively. Correlations of defensive direction with defensive direction away from threat and defensive direction towards threat were $r = .52$ and $r = -.48$, respectively, while defensive intensity correlated only with defensive direction away from threat ($r = .39$). Finally, defensive direction and defensive intensity correlated

positively ($r = .41$), which is very similar to what was obtained in Perkins and Corr (2006) and Perkins et al. (2010).

All correlation coefficients were significant at $p < .01$. These results suggest that defensive direction is not unidimensional, but rather a two-dimensional and orthogonal construct, while defensive intensity is not uniquely captured by the modified threat scenarios.

The correlations between personality and behavioural defensive tendencies are presented in a 14 x 22 correlation matrix. Two main patterns of correlation are most relevant. First, the scales of BIS, Flight and Freezing correlate positively with defensive direction away from threat, and negatively with defensive direction towards threat. The only exception is the BIS of Jackson 5, which correlated very poorly with all defensive behaviours. Secondly, all fight scales correlated positively with defensive direction towards threat. Correlations with defensive direction away from threat were all very small and negative. Hence, individuals high on BIS, Flight and Freezing have greater tendencies to move away from the threat in potentially life-threatening situations. The BIS of Jackson 5 is the only scale that shows a different pattern of correlation. It achieves a very low correlation with all defensive behaviours. In contrast, individuals high on Fight scales have a tendency to actively defend themselves by attacking in the same situations.

Additionally, there are two patterns of correlation between BAS Scales and defensive direction away from threat and defensive direction towards threat. The BAS Scales that correlate positively with defensive direction towards threat and not with defensive direction away from threat are: Drive, Fun seeking, BAS (Jackson 5), Reward Interest and Impulsivity (RST-PQ), and BAS (RSQ). A near-opposite pattern of correlation was observed with Reward responsiveness, Goal-Drive Persistence and Reward reactivity. These results support previous findings of the existence of two BAS types of scale (Krupić & Corr, 2014; Krupić, Gračanin, & Corr, 2016; Smillie, Jackson, & Dalgleish, 2006).

Predictive validity of RST questionnaires was further examined using hierarchical regression analysis, controlling for the effects of gender and age (Table 3). In the first block we entered gender and age, and in the second block we entered scales for each RST questionnaire separately. R^2 change was used to compare predictive validity among different RST questionnaires. They explained between 4.5 and 18.50% of the variance of defensive direction away from threat, and 3.7–16.7% of the variance of defensive direction towards threat. The Jackson 5 explained the most variance, then RST-PQ and RSQ, while significantly lower predictive validity was shown by the BIS/BAS Scales.

Both BIS scales of the BIS/BAS Scales correlated positively with defensive direction away from threat, as did the BIS scales of Jackson 5 and RST-PQ, and only the BIS of RST-PQ correlated negatively with defensive direction towards threat. All Flight/Freezing scales predicted defensive direction away from threat, while only RST-PQ predicted defensive direction towards threat. All Fight scales predicted defensive direction towards threat. Finally, the BAS of RSQ, Impulsivity and Drive predicted defensive direction towards threat, while the rest of the BAS subscales were not significant predictors.

4. Discussion

The main aim of this study was to examine the role of personality traits in predicting defensive behavioural repertoire in the threat scenarios of Blanchard et al. (2001) using a new methodological approach. The second aim was to explore potential bias in results due to differences between various RST purpose-built questionnaires. Using a 5-point scale, and measuring 10 threat reactions for all 12 scenarios, defensive intensity and defensive directions as defined by nominal measurement were replaced by two orthogonal dimensions of defensive direction towards threat and defensive direction away from threat. This modified procedure revealed a different set of results: originally, defensive direction represented a bipolar continuum, while our data indicate that the two sides of the continuum reflect two orthogonal dimensions.

In line with our first hypothesis, we replicated the findings using the original coding system of defensive intensity and defensive direction. Specifically, the BIS and FFFS of all four RST questionnaires correlated positively with defensive intensity and defensive direction, which is line with the previous findings (Perkins & Corr, 2006; Perkins et al., 2010). Furthermore, there are theoretically congruent findings in the correlations between fight/flight/freezing behavioural reactions and their personality-trait namesakes, indicating good predictive validity.

Table 2

Correlation matrix for the four RST questionnaires and defensive intensity, defensive direction, defensive tendency away from and towards the threat and the ten distinct defensive behaviours of the threat scenarios, and descriptive data for the threat scenarios.

	1	2	3	4	5	6	7	8	9	10	11	12	13	14
BIS/BAS Scales														
Drive	.02	-.05	-.05	-.06	.01	.04	.03	.01	-.00	.10*	.08	.09*	.11*	.14**
Fun-seeking	.02	-.01	-.05	-.06	.02	-.01	.01	-.02	-.02	.07	.08	.07	.09	.10*
Reward														
responsiveness	.09*	.15**	.04	.08	.19**	.10*	.14**	.03	.13**	-.07	-.10*	-.04	.08	-.04
BIS-anxiety	.17**	.26**	.24**	.33**	.28**	.20**	.27**	.13*	.32**	-.14**	-.15**	-.16**	.01	-.15**
BIS-fear	.20**	.27**	.19**	.31**	.22**	.16**	.22**	.14**	.25**	-.11*	-.13*	-.22**	-.03	-.18**
Jackson 5														
BAS	-.03	-.02	-.05	-.07	.02	.00	.02	.00	-.01	.04	.04	.15**	.07	.11*
BIS	.06	.09*	.07	.11*	.16**	.10*	.13*	.07	.14**	.01	-.04	.05	.10*	.07
Fight	.04	-.24**	-.11**	-.18**	-.14**	-.05	-.05	-.09*	-.14**	.36**	.38**	.16**	.37**	.44**
Flight	.32**	.36**	.39**	.43**	.40**	.38**	.44**	.30**	.53**	-.05	-.08	-.27**	.07	-.11*
Freezing	.28**	.35**	.40**	.52**	.36**	.32**	.36**	.31**	.50**	-.07	-.12*	-.28**	.03	-.16**
RST-PQ														
Reward interest	-.07	-.08	-.08	-.09*	-.04	-.01	-.02	-.02	-.06	.07	.06	.16**	.02	.11*

Goal-Drive														
persistence	-.00	.05	-.02	.02	.09*	.07	.07	.02	.06	-.04	-.05	.05	.02	.02
Reward reactivity	.09*	.10*	.09*	.13**	.18**	.14**	.18**	.09*	.18**	.05	.01	.03	.11*	.07
Impulsivity	.07	-.02	-.01	.03	.02	.10*	.08	.00	.05	.20	.15	.08	.16	.18**
BIS	.21**	.32**	.28**	.38**	.29**	.24**	.26**	.18**	.36*	-.06	-.10*	-.20**	.04	-.12*
FFFS	.33**	.43**	.38**	.52**	.42**	.37**	.42**	.27**	.53**	-.10*	-.15**	-.31**	.01	-.19**
Defensive fight	.01	-.20**	-.12**	-.14**	-.12*	-.07	-.08	-.11*	-.14**	.29**	.29**	.19**	.27**	.35**
RSQ														
BAS	-.04	-.14**	-.09*	-.14**	-.08	-.01	-.04	-.05	-.08	.19**	.17**	.19**	.10*	.22**
BIS	.21**	.27**	.29**	.39**	.26**	.24**	.27**	.23**	.37**	-.06	-.10*	-.23**	-.01	-.15**
Fight	.09*	-.19**	-.07	-.10*	-.09*	.02	.01	-.06	-.07	.30**	.30**	.12*	.28**	.33**
Flight	.19**	.39**	.35**	.38**	.44**	.29**	.34**	.26**	.45**	-.16**	-.20**	-.23**	.02	-.20**
Freezing	.26**	.30**	.35**	.53**	.31**	.29**	.32**	.28*	.46**	-.09*	-.14**	-.25**	-.05	-.20**
Cronbach's α	.66	.62	.85	.93	.86	.90	.89	.92	.78	.88	.88	.86	.89	.89
M	20.67	16.16	22.78	26.99	36.54	27.69	30.08	22.04	166.10	28.24	29.14	37.40	34.57	129.18
SD	3.26	2.31	7.86	10.97	9.78	10.01	10.31	9.10	46.85	9.53	9.25	9.98	10.03	30.14
Skewness	.12	.00	.71	.40	-.50	.13	-.06	.83	.02	.23	.34	-.08	-.12	.21
Kurtosis	1.29	.12	.29	-.71	-.14	-.79	-.77	-.00	-.43	.34	-.20	-.32	-.60	-.27

Note: 1 — Defensive intensity; 2 — Defensive direction; 3 — Hide; 4 — Freezing; 5 — Run; 6 — Threaten to scream; 7 — Yell/scream; 8 — Beg/plead/negotiate; 9 — Total, defensive direction away from threat; 10 — Threaten to attack; 11 — Attack; 12 — Risk assessment; 13 — Look for a weapon; 14 — Total, defensive direction towards threat.

However, the BIS of all four questionnaires did not correlate with either risk assessment or defensive direction towards threat; this does not meet the predictions of RST, and it also confirms previous findings (Perkins & Corr, 2006; Perkins et al., 2010). The BIS and Flight and Freezing scales represent defensive behaviour that moves away from the threat, while the Fight scales represent defensive behaviour that moves the individual towards the threat. According to the theory, the BIS should show an opposite pattern. The one crumb of comfort was the higher correlation of RST-PQ fear with defensive direction away from threat, as compared with RST-PQ anxiety. Overall, the results provide partial support for the theoretical assumptions. The Flight/Freezing scales predict defensive direction away from threat, while the Fight scales predict defensive direction towards threat.

The most problematic finding is the positive correlation between the BIS and defensive direction away from threat, instead of with defensive direction towards threat (particularly with risk assessment), as was predicted. This finding is not in line with the pharmacologic study of Perkins et al. (2013), where the anxiolytic drug lorazepam had decreased risk-assessment behaviour in anxious individuals. This discrepancy may be caused by the difference between self-report and behavioural experiments. However, in the same study, Perkins et al. (2013) also discuss joint effects of lorazepam on panic and anxiety symptoms. They explain that it is possible that anxiolytic drugs affect threat perception, which can trigger both anxiety and phobia. This may be relevant for evaluation of the items in the RST questionnaires in this study. Items in the BIS scales in all four RST questionnaires refer to end states of anxiety that are very similar to end states of fear. It may be more appropriate if the BIS scales focus on situations that trigger anxiety and related defensive behaviours. According to RST, anxiety rises when approaching a threat, and in the end it will result in a similar emotional state of fear (high arousal). On the other hand, fear should rise moment after the presence of the threat and should result in moving away from the threat. According to this view, highly anxious individuals should have a lower threshold of experiencing anxiety when entering threat situations, while more fearful individuals should express more intense behavioural reaction when the threat is already present. Similarly, this argument also applies for Blanchards' threat scenarios. All items describe final behavioural manifestations, without describing the processes that precede the final behavioural output. In light of this, the BIS and FFFS, both predicting defensive direction away from threat, can be interpreted as being consistent with RST if we assume that they concern end states. Therefore, before coming to any final conclusions concerning defensive direction of anxiety, it may be more suitable to use behavioural tasks or more carefully planned experimental studies that could operationalize processes underlying the BIS.

Table 3. Hierarchical regression analysis for RST questionnaires in prediction of Defensive direction away threat and Defensive direction toward threat controlled for effects of gender and age

		Defensive direction away threat				Defensive direction toward threat			
Predictors and step		β	R ²	ΔR^2	ΔF	β	R ²	ΔR^2	ΔF
<i>BIS/BAS Scales</i>									
1	Gender	-.498**	.265	.265	173.488**	.295**	.087	.087	45.899**
	Age	-.096**				.000			
2	Gender	-.433**	.310	.045	12.602**	.268**	.124	.037	8.073**
	Age	-.092**				.000			
	Drive	-.001				.143**			
	Fun Seeking	-.030				.066			
	Reward responsiveness	-.003				-.069			
	BIS-Anxiety	.150**				-.024			
	BIS-Fear	.115**				-.078*			
<i>Jackson -5</i>									
Predictors and step		β	R ²	ΔR^2	ΔF	β	R ²	ΔR^2	ΔF
1	Gender	-.498**	.265	.265	173.488**	.295**	.087	.087	45.899**
	Age	-.096**			64.166**	.000			
2	Gender	-.341**	.450	.185		.207**	.254	.167	42.903**
	Age	-.067**				-.017			
	BAS	.000				.017			
	BIS	.080**				-.052			
	Fight	-.112**				.415**			
	Flight	.273**				-.014			

		<i>RST-PQ</i>				<i>RSQ</i>			
Freezing									
		β	R ²	ΔR^2	ΔF	β	R ²	ΔR^2	ΔF
		.197**				-.069			
<i>RST-PQ</i>									
Predictors and step		β	R ²	ΔR^2	ΔF	β	R ²	ΔR^2	ΔF
1	Gender	-.498**	.265	.265	173.488**	.295**	.087	.087	45.899**
	Age	-.096**				.000			
2	Gender	-.336**	.424	.158	37.498**	.232**	.216	.129	22.404**
	Age	-.061*				-.013			
	Reward Interest	-.020				-.030			
	Goal Drive Persistence	-.007				-.053			
	Reward reactivity	.077*				.047			
	Impulsivity	-.004				.092**			
	BIS	.072*				-.081*			
	FFFS	.346**				-.089*			
	Defensive fight	-.144**				.297**			
<i>RSQ</i>									
Predictors and step		β	R ²	ΔR^2	ΔF	β	R ²	ΔR^2	ΔF
1	Gender	-.498**	.265	.265	173.488**	.295**	.087	.087	45.899**
	Age	-.096**				.000			
2	Gender	-.374**	.409	.143	46.435**	.248**	.206	.119	28.678**
	Age	-.073**				.003			
	BAS	-.035				.100**			
	BIS	.027				.003			
	Fight	.021				.271**			
	Flight	.210**				-.034			
	Freezing	.229**				-.078*			

To conclude, three of the four RST questionnaires (BIS/BAS Scales, RSQ and RST-PQ) highly converge in the BIS scales. The exception is the BIS of Jackson 5, which has the most distinct correlations with the threat scenarios (for more details, see Corr, 2016; Krupić, et al., submitted for publication). Furthermore, the BIS/BAS Scales show the lowest predictive validity for defensive behaviours. Although the BIS of the BIS/BAS Scales correlates highly with the BIS of RSQ and of RST-PQ, separating the 7-item scale into two very small subscales (BIS-anxiety and BIS-fear) can result in reduced variance and a lower reliability coefficient. These two can significantly attenuate correlation with external variables. Thus, it should be more suitable to use RSQ and RST-PQ in the study of defensive behaviour. Finally, Blanchard's threat scenarios differentiate two defensive behaviours that are distinguished by direction, and this is not appropriate as an instrument of defensive intensity.

References

- Beck, I., Smits, D.J.M., Claes, L., Vandereycken, W., & Bijttebier, P. (2009). Psychometric evaluation of the behavioral inhibition/behavioral activation system scales and the sensitivity to punishment and sensitivity to reward questionnaire in a sample of eating disordered patients. *Personality and Individual Differences, 47*, 407–412. <http://dx.doi.org/10.1016/j.paid.2009.04.007>.
- Bernat, J.A., Calhoun, K.S., & Adams, H.E. (1999). Sexually aggressive and nonaggressive men: Sexual arousal and judgments in response to acquaintance rape and consensual analogues. *Journal of Abnormal Psychology, 108*, 662–673. <http://dx.doi.org/10.1037/0021-843X.108.4.662>.
- Blanchard, C.D., Hynd, A.L., Minke, K.A., Minemoto, T., & Blanchard, R.J. (2001). Human defensive behaviors to threat scenarios show parallels to fear- and anxiety-related defense patterns of non-human mammals. *Neuroscience and Biobehavioral Reviews, 25*, 761–770. [http://dx.doi.org/10.1016/S0149-7634\(01\)00056-2](http://dx.doi.org/10.1016/S0149-7634(01)00056-2).
- Blanchard, D.C., Griebel, G., Pobbe, R., & Blanchard, R.J. (2011). Risk assessment as an evolved threat detection and analysis process. *Neuroscience and Biobehavioral Reviews, 35*(4), 991–998. <http://dx.doi.org/10.1016/j.neubiorev.2010.10.016>.
- Carver, C.S., & White, T.L. (1994). Behavioral inhibition, behavioral activation, and affective responses to impending reward and punishment: The BIS/BAS Scales. *Journal of*

- Personality and Social Psychology*, 67(2), 319–333. <http://dx.doi.org/10.1037/0022-3514.67.2.319>.
- Conklin, C.A., Tiffany, S.T., & Vrana, S.R. (2000). The impact of imagining completed versus interrupted smoking on cigarette craving. *Experimental and Clinical Psychopharmacology*, 8, 68–74. <http://dx.doi.org/10.1037/1064-1297.8.1.68>.
- Corr, P.J. (2008). Reinforcement sensitivity theory (RST): Introduction. In P.J. Corr (Ed.), *The reinforcement sensitivity theory and personality* (pp. 1–28). Cambridge: Cambridge University Press. <http://dx.doi.org/10.1017/CBO9780511819384.002>.
- Corr, P. J. (2013). Approach and avoidance behavior: Multiple systems and their interactions. *Emotion Review*, 5, 286–291. <http://dx.doi.org/10.1177/1754073913477507>.
- Corr, P. J. (2016). Reinforcement sensitivity theory of personality questionnaires: Structural survey with recommendations. *Personality and Individual Differences*, 89, 60–64. <http://dx.doi.org/10.1016/j.paid.2015.09.045>.
- Corr, P. J., & Cooper, A. (2016). The Corr-Cooper Reinforcement Sensitivity Theory Personality Questionnaire (RST-PQ): Development and validation. *Psychological Assessment*. <http://dx.doi.org/10.1037/pas0000273>. *In press*.
- Corr, P.J. (2011). Anxiety: Splitting the phenomenological atom. *Personality and Individual Differences*, 50, 889–897. <http://dx.doi.org/10.1016/j.paid.2010.09.013>.
- Corr, P.J., & McNaughton, N. (2008). Reinforcement sensitivity theory and personality. In P.J. Corr (Ed.), *The Reinforcement Sensitivity Theory of Personality* (pp. 155–187). Cambridge: Cambridge University Press. <http://dx.doi.org/10.1017/CBO9780511819384.003>.
- Corr, P.J., & McNaughton, N. (2012). Neuroscience and approach/avoidance personality traits: A two stage (valuation–motivation) approach. *Neuroscience and Biobehavioral Reviews*, 36, 2339–2354. <http://dx.doi.org/10.1016/j.neubiorev.2012.09.013>.
- Ein-Dor, T., & Perry-Paldi, A. (2014). Human reaction to threat: Examining the interplay between personality dispositions and situational features. *Psychological Research*, 4, 599–622 (Retrieved from http://www.researchgate.net/profile/Tsachi_Ein-Dor/publication/269053771_Human_Reaction_to_Threat_Examining_the_Interplay_Between_Personality_Dispositions_and_Situational_Features/links/547ebd8f0cf2c1e3d2dc240a.pdf).
- Erber, J.T., Szuchman, L.T., & Prager, I.G. (2001). Ain't misbehavin': The effects of age and intentionality on judgments about misconduct. *Psychology and Aging*, 16, 85–95. <http://dx.doi.org/10.1037/0882-7974.16.1.85>.

- Gray, J.A., & McNaughton, N. (2000). *The neuropsychology of anxiety (2nd ed.)*. New York: Oxford University Press.
- Jackson, C.J. (2009). Jackson-5 scales of revised Reinforcement Sensitivity Theory (r-RST) and their application to dysfunctional real world outcomes. *Journal of Research in Personality*, 43, 556–569. <http://dx.doi.org/10.1016/j.jrp.2009.02.007>.
- Krupić, D., & Corr, P.J. (2014). Individual differences in emotion elicitation in university examinations: A quasi-experimental study. *Personality and Individual Differences*, 71, 176–180. <http://dx.doi.org/10.1016/j.paid.2014.08.001>.
- Krupić, D., Gračanin, A., & Corr, P.J. (2016). The evolution of the behavioural approach system (BAS): Cooperative and competitive resource acquisition strategies. *Personality and Individual Differences*. <http://dx.doi.org/10.1016/j.paid.2016.01.044> (in press).
- Krupić, D., Križanić, V., Ručević, S., Gračanin, A., & Corr, P.J. (2016). Reinforcement Sensitivity Theory (RST) of personality questionnaires: Comparison, validity and generalization. (*submitted for publication*).
- McNaughton, N., & Corr, P.J. (2004). A two-dimensional neuropsychology of defense: Fear/anxiety and defensive distance. *Neuroscience and Biobehavioral Reviews*, 28(3), 285–305. <http://dx.doi.org/10.1016/j.neubiorev.2004.03.005>.
- Mesquita, S.C.V., Shuhama, R., Osorio, F.L., Crippa, J.A.S., Loureiro, S.R., Landeira-Fernandez, J., & Del-Ben, C.M. (2011). The response of social anxiety disorder patients to threat scenarios differs from that of healthy controls. *Brazilian Journal of Medical and Biological Research*, 44(12), 1261–1268. <http://dx.doi.org/10.1590/S0100-879X2011007500137>.
- Pappens, M., Claes, L., Versleegers, T., Vansteenwegen, D., Van den Bergh, O., & Van Diest, I. (2013). Disentangling fear and anxiety in self-reported responses to situational scripts. *Psychological Topics*, 22(2), 221–236 (Retrieved from: <http://hrcak.srce.hr/file/159879>).
- Perkins, A.M., & Corr, P.J. (2006). Reactions to threat and personality: Psychometric differentiation of intensity and direction dimensions of human defensive behaviour. *Behavioural Brain Research*, 169(1), 21–28. <http://dx.doi.org/10.1016/j.bbr.2005.11.027>.
- Perkins, A.M., Cooper, A., Abdelall, M., Smillie, L.D., & Corr, P.J. (2010). Personality and defensive reactions: Fear, trait anxiety, and threat magnification. *Journal of Personality*, 78(3), 1071–1090. <http://dx.doi.org/10.1111/j.1467-6494.2010.00643.x>.
- Perkins, A.M., Ettinger, U., Weaver, K., Schmechtig, A., Schranter, A., Morrison, P.D., ... Corr, P.J. (2013). Advancing the defensive explanation for anxiety disorders: Lorazepam effects on human defense are systematically modulated by personality and threat-type. *Translational Psychiatry*, 3(4), e246 <http://doi.org/10.1038/tp.2013.20>.

- Shuhama, R., Del-Ben, C.M., Loureiro, S.R., & Graeff, F.G. (2007). Animal defense strategies and anxiety disorders. *Anais da Academia Brasileira de Ciências*, 79(1), 97–109. <http://dx.doi.org/10.1590/S0001-37652007000100012>.
- Smederevac, S., Mitrović, D., Čolović, P., & Nikolašević, Ž. (2014). Validation of the measure of revised reinforcement sensitivity theory constructs. *Journal of Individual Differences*, 35(1), 12–21. <http://dx.doi.org/10.1027/1614-0001/a000121>.
- Smillie, L.D., Jackson, C.J., & Dalgleish, L.I. (2006). Conceptual distinctions among Carver and White's (1994) BAS scales: A reward-reactivity versus trait impulsivity perspective. *Personality and Individual Differences*, 40(5), 1039–1050. <http://dx.doi.org/10.1016/j.paid.2005.10.012>.

7.3

Individual differences in emotion induction in university examinations

Krupić, D., Corr, P.J. (2014)

Personality and Individual Differences, 71, 176-180.

7.3. Individual differences in emotion elicitation in university examinations: A quasi-experimental study

Abstract

In a quasi-experimental study, we examined the role of individual differences in the elicitation of emotional states in university examinations. Specifically, we assessed emotional states (a) before the first examination (baseline), (b) after receiving positive or negative feedback, and (c) then, again, before a series of subsequent examinations. We also measured effort in examination preparation and interest for studying. Data were collected during a university course that consisted of seven examinations in one semester; and 94 female students completed the BIS/BAS scales and SPSRQ (to measure sensitivity to punishment, SP, and reward, SR). Results revealed that higher BAS, but not SR, individuals experienced higher positive affect (PA) following positive feedback and they also showed higher levels of interest in studying. More generally, higher BIS and SP individuals experienced higher level of negative affect (NA) and they invested more effort in examination preparation; and both higher levels of SP and SR correlated positively with NA after receiving negative feedback. In addition, following negative feedback, higher BAS individuals experienced lower levels of PA, and higher SR individuals invested less effort in examination preparation. Results are discussed in terms of the reinforcement sensitivity theory (RST) of personality and directions for future research.

Keywords: Test anxiety, Reinforcement sensitivity theory, Individual differences, Examination performance, Personality, Reward Punishment

1. Introduction

Academic tasks are prone to evoke a variety of emotions in students, and these emotional experiences impact academic performance. In this context, test anxiety is one of the most common emotional experiences (Pekrun, Goetz, Titz, & Perry, 2002), and it correlates negatively with: (a) cumulative grades-point average (Diener, Schwarz, & Nickerson, 2011); (b) academic performance (Pekrun, Elliot, & Maier, 2009); and (c) students' health (Conley & Lehman, 2012). Test anxiety and emotional reactivity to test feedback are influenced by both

situational and trait factors (Putwain, Woods, & Symes, 2010). In addition to the main effect of examination-related situational anxiety, individual differences in reactions involve achievement goals (Putwain & Daniels, 2010; Putwain & Symes, 2012; Putwain et al., 2010), neuroticism (Chamorro-Premuzic, Ahmetoglu, & Furnham, 2008), perfectionism (Stoeber, Feast, & Hayward, 2009), locus of control (Davis & Davis, 1972), and even a birth order (Sarason, 1969).

Test anxiety is a multidimensional construct consisting of cognitive and emotional factors (Cassidy & Johnson, 2002), with worry being the most important cognitive feature (Øktedalen & Hagtvet, 2011). Recent studies call attention to the role played by metacognitive aspects, such as beliefs about cognitive competence, uncontrollability and danger, and cognitive self-consciousness or automatic thoughts, such as fear of failure and fear of disappointing parents (Zivcic-Becirevic, Juretic, & Miljevic, 2009). Besides metacognitive factors in test anxiety, the most studied and important personality factors are neuroticism (Chamorro-Premuzic et al., 2008; Dobson, 2000; Halamandaris & Power, 1999) and trait anxiety (Beidel & Turner, 1988; Elliot & McGregor, 1999). Moreover, it seems that personality traits play the most important role in test anxiety. Specifically, neuroticism is a better predictor of test anxiety than core self-evaluation (Chamorro-Premuzic et al., 2008), such as self-efficiency, self-esteem and locus of control (Judge & Bono, 2002). This is not surprising given that general anxiety is one of facets of neuroticism in the five-factor model (Costa & McCrae, 1992). Thus, as test anxiety shares many conceptual characteristics with traits reflecting anxiety or negative emotionality, correlations between them may be a result of conceptual similarities rather than an effect of some explanatory mechanism.

There are a number of unresolved issues in the test anxiety literature. First, there has been little research on other emotional states experienced during situations that evoke test anxiety, specifically broader positive and negative affectivity. Secondly, little attention has been paid to the role of individual differences that could explain variation in these states. Thirdly, we do not know how past test feedback influences emotion elicitation in subsequent examinations – this is likely to be important in terms of emotional and motivational knock-on effects. To address these issues, we explore: (a) the role of trait individual differences in emotional states prior to an examination (test anxiety); (b) after the examination feedback is provided; and (c) once again just before the student sits subsequent examinations.

One lens through which to view individual difference in such emotional states is afforded by the reinforcement sensitivity theory (RST) of personality (Corr, 2013). RST was originally based on the studies of reactions to punishment and reward in typical animal learning

paradigms. In its current form (Corr & McNaughton, 2008, 2012) it postulates three general domain systems explaining reactions to reward, punishment, and their conflict. The Behavioral Approach System (BAS) mediates reactions to all appetitive stimuli (which include relief from nonpunishment). The Fight/Flight/ Freezing System (FFFS) mediates reactions to all aversive stimuli (which include frustrative non-reward). The Behavioral Inhibition System (BIS) is hypothesized to be active in conflict situations that entail specific opposing approach (BAS) and avoidance (FFFS) goals, as well as goal-conflict more generally. Individuals higher on the BAS are proposed to be higher on extraversion and impulsivity; whereas individuals higher on the BIS are proposed to be higher on neuroticism and anxiety; and finally, the FFFS is a defensive mechanism that underlies fear and panic and, like the BIS, is related to neuroticism (Corr, DeYoung, & McNaughton, 2013). In general terms, variation in BAS reflects sensitivity to reward, while the variations in BIS and FFFS together reflect sensitivity to punishment (Corr, 2008; this provides a summary of RST). In this study, we do not differentiate the FFFS and BIS, but treat both as reflections of different aspects of punishment sensitivity.

The first aim of this study is to explore the role of sensitivity to reward and sensitivity to punishment in examination test settings in terms of the elicitation of positive and negative emotional states; and the second aim is to examine the emotions evoked by knowledge of previous examination performance (feedback). From an RST perspective, individuals higher on BIS and FFFS should be more reactive to cues of punishment and conflict. Two general hypotheses are tested. First, as the BIS (including the FFFS) mediates emotion and behavior in punishing situations, we expect a positive correlation with degree of negative affectivity generated following negative examination feedback. Secondly, sensitivity to reward (SR) or BAS should mediate reactions to both to reward and non-punishment stimuli and, thus, we expect that individuals higher on BAS and SR should feel more positive affect following favourable examination feedback.

When measuring emotional states in an academic context, there is the opportunity to conduct studies with real life observation, what Wallbott and Scherer (1989) describe as an ideal setting to study emotional experience. However, studies conducted in such settings entail methodological and ethical concerns. The strength of experimental studies is their internal validity, while for self-report studies (such as diary method sampling or correlation studies) the strength is external, or ecological, validity. In real life observation, internal validity can be diminished due to many uncontrollable factors that increase measurement error. On the other hand, mood induction in experimental studies is typically done by creating an artificial situation through presentation of stimuli, such as movie clips (Schaefer, Nils, Sanchez, & Philippot,

2010), pictures (Lang, Bradley, & Cuthbert, 2008), or music (Coutinho & Cangelosi, 2011) that provide a greater degree of experimental control, which gains much in terms of internal validity but loses in terms of external validity: this represents an important shortcoming in comparison to those studies conducted with diary experience sampling method.

The question is how findings from more artificial mood induction procedures can be generalized to test anxiety in more realistic academic settings. For this reason, we conducted a real life, quasi-experimental, study, since this methodology provides the greatest degree of ecological validity. In addition, there are ethical concerns with studies when the lecturer is performing a study on his or her students. In order to prevent this ethical concern, it is important to ensure anonymity of the participants' data. This also has a beneficial impact on the validity of data collected because it goes a long way to avoiding socially desirable responding. Our quasi-experimental study was designed with these theoretical and methodological considerations in mind.

2. Method

2.1. Participants

A total of 94 female university students, ranging in age from 19 to 24 years ($M = 21.86$ and $SD = 1.43$), participated in the study during an obligatory courses in their first and second academic years at the Department of psychology, University of J.J. Strossmayer, Croatia. All students participated in exchange to course credit.

2.2. Materials

Two questionnaires measuring personality traits, one assessing emotions, and one an evaluation list, designed specifically for this study, were administered. They were administered in the Croatian language.

2.2.1. BIS/BAS Scales

BIS/BAS Scales (Carver & White, 1994) consist of 13 items to assess reactivity of the BAS, which can be measured either on a unidimensional scale or divided into three subscales:

BAS Drive (4 items; example item “When I want something, I usually go all-out to get it”), BAS Fun seeking (4 items; example item “I crave excitement and new sensations”) and BAS Reward responsiveness (5 items; example item “It would excite me to win a contest”); and 7 items to assess reactivity of the BIS (example item “I worry about making mistakes”) measured on a unidimensional scale. Items are answered on 4-point Likert scale ranging from 1 (Strongly disagree) to 4 (Strongly agree).

In this study, Cronbach alpha reliability coefficients for BAS Total, Drive, Fun-Seeking, Reward responsiveness and BIS were .81, .80, .72, .68, and .80, respectively.

2.2.2. Sensitivity to Punishment and Sensitivity to Reward Questionnaire (SPSRQ)

SPSRQ (Torrubia, Avila, Moltó, & Caseras, 2001) consists of 48 items, 24 items measuring Sensitivity to Reward (SR; example item “Does the good prospect of obtaining money motivate you strongly to do some things?”) and 24 items measuring Sensitivity to Punishment (SP; example item “Are you often afraid of new or unexpected situations?”). All items are answered on dichotomous scale of Yes/ No format. In this study, Cronbach alphas for SP and SR were .85 and .77, respectively.

Both, the BIS/BAS scales and SPSRQ are translated and validated in Croatian (Krupić, Corr, Ručević, Križanić, & Gračanin, 2014).

2.2.3. Positive Affect and Negative Affect Schedule (PANAS)

PANAS (Watson, Clark, & Tellegen, 1988) consists of 20 items: 10 measuring Positive Affect (PA) and 10 measuring Negative Affect (NA). All items are answered on 5 point Likert scale. In this study, Cronbach alphas for PA and NA ranged from .78 to .84, and .80 to .87, respectively. The questionnaire was translated and validated in the Croatian language (Knezović & Križanić, 2011).

2.2.4. Evaluation list (EL)

EL consists of 14 questions of different contexts, and served generally as a method to mask the hypothesis of the study. From the list, we used three items referring to: (a) the level of effort invested in examination preparation; (b) level of interest for the test; and (c) level of satisfaction with received grade. Since they were not related to the topic of this study, other items were not used in data analysis (the list can be found in Appendix A).

2.3. Design and procedure

In order to measure emotional states in a real life situation, a quasi-experimental study was conducted during an obligatory university course. The course included seven tests during one semester. No intervention or manipulations were employed. Participants completed the PANAS: just before they started their first examination (baseline); after they received their test results; and then before each of the subsequent examinations.

Conditions for positive and negative test feedback were operationalized by: (a) the relationship between received and expected grade; and (b) the level of satisfaction with the received grade obtained as assessed by the self-report evaluation list. If the received grade was lower than expected, then this condition was classified as negative test feedback. If the received grade was higher than expected, then this condition was categorized as a positive test feedback. In the case where there was no difference between received and expected grade, an additional criterion was used (e.g., if a student was expecting to receive 4 and she received a 4, then the variable of satisfaction with the received grade was used to determine measurement condition). On the 5-point scale of the variable, we interpreted answers 1 or 2 as dissatisfaction with a grade indicating negative test outcome, while answers 4 and 5 were interpreted as satisfaction with a grade, indicating positive test outcome (see Appendix B).

Emotional states for all conditions were calculated as arithmetic means for PA and NA. In this way, there are six dependent variables: PA and NA taken just before the first examination (baseline); PA and NA just after students received their examination feedback; and, then, PA and NA on each of the subsequent testing sessions. For subsequent examinations, mean PA and NA were subtracted from baseline PA/NA to derive a change score.

Procedures to avoid the problem of demand characteristics were employed (Klein et al., 2012). First, students participated under an anonymous password in order to ensure they more

freely reported their emotional states. Secondly, along with PANAS before and after examinations, the evaluation list with several fillers was administered in order to mask the aims of the study.

The ethical board of Department of psychology in Osijek gave the ethical approval for this study.

3. Results

Table 1 presents the descriptive statistics for the two emotional states before the first examination (baseline) and then after receiving feedback. These data were subjected to repeated-measures ANOVA on total of 80 participants who had complete data. First, we tested requirements for repeated ANOVA by Mauchly's test of sphericity, which was not significant ($p > 0.05$) for both PA and NA. Both independent variables and their interaction were statistically significant at the $p < 0.001$, level: $F(2,158) = 27.85$ with $g^2 = .261$ for Condition; $F(1,77) = 15.53$ and $g^2 = .164$ for Affect; and finally $F(2,158) = 206.98$ and $g^2 = .724$ for the Condition Affect interaction. g^2 indicates strong effects of conditions on students' emotional states. In the positive test feedback group, PA was much higher than NA; and this pattern was reversed in the negative test feedback group; and both feedback-related emotional states differed from baseline.

3.1. Emotional states

Correlations revealed that students higher on BIS, SP and SR experienced a higher level of NA. Students higher on Drive experienced a higher level of PA in positive test feedback, while in the same group students higher on Reward responsiveness experienced a lower level of NA. Finally, students higher on SP and SR experienced higher level of NA following negative test feedback (see Table 2).

3.2. Motivational variables

Students higher on BIS and SP reported higher levels of effort invested in examination preparation; and students higher on SR showed lower, while those higher on Drive, showed higher levels of interest for the topic of the course.

Correlations revealed relations between RST scales and changes in level of PA and NA following positive and negative test feedback (Table 3). After negative test outcome, individuals higher on BAS Total (but especially Reward responsiveness) experienced lower levels of PA. There were no statistically significant correlations between personality scales and changes of emotional states after positive test feedback.

Finally, on a motivational level, there were no individual differences in effort after negative test feedback, while after positive test feedback there was decreased level of effort in examination preparation for individuals higher on SR.

Table 1

Descriptive statistics for PANAS in all three experimental conditions.

		r	n	M	SD	Min	Max
Baseline	PA	.11	94	25.36	6.28	13.00	48.43
	NA			25.89	6.35	12.14	41.50
Positive test feedback	PA	.18	91	32.95	7.09	18.00	48.67
	NA			16.14	5.27	10.00	28.00
Negative test feedback	PA	.09	84	19.46	5.45	10.00	34.00
	NA			26.29	7.42	10.75	43.00

Note. [†]p < .05, ^{**}p < .01, two-tailed. n = number of participants.

4. Discussion

As expected, punishment sensitivity, as measured by BIS and SP, correlated positively with NA just before the first test, at baseline. Additionally, we examined the role of individual differences in motivational aspects defined as effort invested in examination preparation and level of interest to study. Individuals higher on BIS and SP invested more effort. This was expected on the basis of the RST operationalization of BIS behavioral repertoire when an

individual is approaching aversive situation with caution (Corr, 2008). An alternative explanation of these results can be related to fear of failure construct. Further studies are needed to tease apart these two different possibilities.

Consistent with expectation, individuals higher on the BAS experienced higher PA after positive test feedback. The same result was expected for SR, but not observed. Furthermore, SR, but not BAS, correlated positively with NA just before the test and then again after negative test feedback. Similar findings can be found in previous studies (Dufey, Fernández, & Mourgues, 2011; Smillie & Jackson, 2005), where BAS but not SR correlated with PA, and SR but not BAS correlated with NA.

Table 2. Correlations between PA and NA in all three situations with SPSRQ and BIS/BAS scales

	Baseline		Positive test feedback		Negative test feedback		Motivation	
	PA	NA	PA	NA	PA	NA	GLE	GLI
BAS Total	.01	.06	.21*	-.21*	-.03	.08	.00	.15
BAS Drive	.07	-.07	.20*	-.18	.02	-.10	.05	.27*
BAS Fun seeking	-.07	.11	.10	-.08	.03	.15	-.11	-.08
BAS Reward responsiveness	.03	.10	.16	-.24*	-.17	.16	.09	.16
BIS	-.02	.23*	.05	.07	-.06	.11	.29**	-.09
SR	.12	.33**	.18	.14	.02	.45**	.03	-.20*
SP	-.13	.35**	-.04	.22*	-.11	.21*	.26**	-.15

GLE – general level of effort; GLI – general level of interest; * $p < .05$.; ** $p < .01$.

These differences can be explained by different views of the underlying personality trait of the BAS. Torrubia et al. (2001) suggest impulsivity, while Depue and Collins (1999) propose extraversion, as underlying personality trait. Based on our results, the Carver and White (1994) BAS scale seems conceptually more similar to extraversion, since extraversion correlates positively only with PA (Larsen & Ketelaar, 1991). Additional analyses related to motivational variables of effort also confirmed differences between these SR and BAS scales.

It was expected that, over the series of examinations, negative test feedback would increase the level of NA, especially for individuals higher on BIS or SP, but that was not observed. Table 3 shows only a near significant positive correlation with PA. One explanation can be that high BIS individuals after negative test feedback invest more effort in examination preparation, and in that way they feel more secure or prepared for the next examination. Additional analysis supported this interpretation: there was a significant correlation between effort invested in examination preparation after negative test feedback.

Table 3. Correlation matrix for personality scales and changes (compared to baseline) of PA and NA after positive and negative test feedback

	Negative test outcome			Positive test outcome		
	PA	NA	Effort	PA	NA	Effort
BAS Total	-.25*	.10	-.04	.14	-.05	-.02
BAS Drive	-.13	.09	-.04	.16	.05	-.07
BAS Fun seeking	-.16	.08	.02	.15	-.19	-.01
BAS Reward responsiveness	-.30**	.06	-.09	-.03	.06	.07
BIS	.19	-.05	.07	-.08	.07	.11
SP	.13	-.09	-.04	-.01	.06	.05
SR	-.17	-.03	.01	.09	-.12	-.26*

* $p < .05$.; ** $p < .01$.

A somewhat unexpected finding was that individuals higher on Reward responsiveness experienced lower levels of PA after negative test feedback. Finally, additional motivational variables indicated another conceptual difference between BAS and SR scales. With regard to SR, there was a negative correlation with effort change after receiving positive test feedback while BAS individuals did not show this tendency.

4.1. Limitation of the study

In real life studies, effects sizes are usually smaller than in true experiments, which is a result of uncontrolled factors influencing the dependent variables. Hence, in future studies with more controlled conditions and with more participants, even stronger effects can be expected. Furthermore, as single items can reduce variability and, therefore, correlations with external variables, in future studies it would be appropriate to use an approximate measure of effort such as time spent in examination preparation (e.g. in hours) instead of estimation of invested effort on 5-point Likert-type response scale.

We did not differentiate the FFFS and BIS as currently there are no agreed scales for these constructs within RST. An important focus of future research should be to compare the roles played by these two major defensive systems in emotion elicitation in educational settings. Appropriate scales are starting to emerge that should facilitate this research objective (Corr & Cooper, 2014), but their value awaits empirical scrutiny. Thus, having in mind methodological weakness of this real life study, future studies in more controllable conditions are required to confirm or replicate findings of this study.

In conclusion, our study provides insight into students' emotional experiences in real-life academic settings, and the roles played by systems of sensitivity to reward and punishment. They show significant effects of examination feedback on emotional elicitation and reveal that personality differences predict these states. On the basis of our findings, the interaction of sensitivity to reinforcement and personality deserves much more attention than it has hitherto received in the higher educational literature.

Appendix A. Evaluation list administered immediately after finishing the test

- | | | | | | | |
|---|--|---|---|---|---|---|
| 1 | Was this test hard or complicated for you | 1 | 2 | 3 | 4 | 5 |
| 2 | How much effort in preparation have you been invested in preparation for this test | 1 | 2 | 3 | 4 | 5 |
| 3 | Are you satisfied with how your test has turned out | 1 | 2 | 3 | 4 | 5 |
| 4 | Do you see this test as challenging | 1 | 2 | 3 | 4 | 5 |
| 5 | Do you think you can further improve your knowledge of methodology and statistics | 1 | 2 | 3 | 4 | 5 |
| 6 | Did you find topic of test interesting | 1 | 2 | 3 | 4 | 5 |
| 7 | Do you think you are ready to make your own study by yourself | 1 | 2 | 3 | 4 | 5 |
| 8 | Do you like the way of work in this course | 1 | 2 | 3 | 4 | 5 |
| 9 | Do you think that you gave your best in this test | 1 | 2 | 3 | 4 | 5 |

*1 – Not at all; 2 – A little bit; 3 – Moderate; 4 – Quite yes; 5 – Definitely yes.

10 Which mark (or grade) you are expecting to get for this report: _____

Appendix B. Evaluation list administered immediately after receiving evaluated report

1	What mark did you received: _____					
2	Are you satisfied with the received mark	1	2	3	4	5
3	Are you satisfied with the quality of corrector's feedback	1	2	3	4	5
4	Are you satisfied with your report in global	1	2	3	4	5
5	Do you believe that you could do better in next report	1	2	3	4	5

*1 – Not at all; 2 – A little bit; 3 – Moderate; 4 – Quite yes; 5 – Definitely yes.

References

- Beidel, D. C., & Turner, S. M. (1988). Comorbidity of test anxiety and other anxiety disorders in children. *Journal of Abnormal Child Psychology*, *16*, 275–287.
- Carver, C. S., & White, T. L. (1994). Behavioral inhibition, behavioral activation, and affective responses to impending reward and punishment: The BIS/BAS Scales. *Journal of Personality and Social Psychology*, *67*, 319–333.
- Cassidy, J. C., & Johnson, R. E. (2002). The influence of cognitive test anxiety across the learning testing cycle. *Learning and Instruction*, *14*, 569–592.
- Chamorro-Premuzic, T., Ahmetoglu, G., & Furnham, A. (2008). Little more than personality: Dispositional determinants of test anxiety (the Big Five, core self-evaluations, and self-assessed intelligence). *Learning and Individual Differences*, *18*, 258–263.
- Conley, K. M., & Lehman, B. J. (2012). Test anxiety and cardiovascular responses to daily academic stressors. *Stress and Health*, *28*, 41–50.
- Corr, P. J. (2008). Reinforcement sensitivity theory (RST): Introduction. In P. J. Corr (Ed.), *The Reinforcement Sensitivity Theory of Personality* (pp. 1–43). Cambridge: Cambridge University Press.
- Corr, P. J. (2013). Approach and avoidance behavior: Multiple systems and their interactions. *Emotion Review*, *5*, 286–291.
- Corr, P. J., & Cooper, A. (2014). The Reinforcement Sensitivity Theory Personality Scales (RST-PQ): Development and validation. *In submission*.
- Corr, P. J., & McNaughton, N. (2008). Reinforcement Sensitivity Theory and personality. In P. J. Corr (Ed.), *The Reinforcement Sensitivity Theory of Personality* (pp. 155–187). Cambridge: Cambridge University Press.
- Corr, P. J., & McNaughton, N. (2012). Neuroscience and approach/avoidance personality traits: A two stage (valuation–motivation) approach. *Neuroscience and Biobehavioral Reviews*, *36*, 2339–2354.
- Corr, P. J., DeYoung, C. G., & McNaughton, N. (2013). Motivation and personality: A neuropsychological perspective. *Social and Personality Psychology Compass*, *7*, 158–175.
- Costa, P. T., & McCrae, R. R. (1992). *NEO personality inventory – revised: Manual*. Lutz, FL: Psychological Assessment Resources.
- Coutinho, E., & Cangelosi, A. (2011). Musical emotions: Predicting second-by-second subjective feelings of emotion from low-level psychoacoustic features and physiological measurements. *Emotion*, *11*, 921–937.

- Davis, W. L., & Davis, D. E. (1972). Internal external control and attribution of responsibility for success and failure. *Journal of Personality, 40*, 123–136.
- Depue, R. A., & Collins, P. F. (1999). Neurobiology of the structure of personality: Dopamine, facilitation of incentive motivation, and extraversion. *Behavioral and Brain Sciences, 22*, 518–569.
- Diener, E., Schwarz, N., & Nickerson, C. (2011). Positive affect and college success. *Journal of Happiness Studies, 12*, 717–726.
- Dobson, P. (2000). An investigation into the relationship between neuroticism, extraversion and cognitive test performance in selection. *International Journal of Selection and Assessment, 8*, 99–109.
- Dufey, M., Fernández, A. M., & Mourgues, C. (2011). Assessment of the behavioral inhibition system and the behavioral approach system: Adaptation and validation of the Sensitivity to Punishment and Sensitivity to Reward Questionnaire (SPSRQ) in a Chilean sample. *The Spanish Journal of Psychology, 14*, 432–440.
- Elliot, A. J., & McGregor, H. A. (1999). Test anxiety and the hierarchical model of approach and avoidance achievement motivation. *Journal of Personality and Social Psychology, 76*, 628–644.
- Halamandaris, K. F., & Power, K. G. (1999). Individual differences, social support and coping with the examination stress: A study of the psychosocial and academic adjustment of first year home students. *Personality and Individual Differences, 26*, 665–685.
- Judge, T. A., & Bono, J. E. (2002). A rose by any other name: Are self-esteem, generalized self-efficacy, neuroticism, and locus of control indicators of a common construct? In B. W. Roberts & R. T. Hogan (Eds.), *Personality Psychology in the Workplace* (pp. 93–118). Washington, DC: American Psychological Association.
- Klein, O., Doyen, S., Leys, C., Miller, S., Questienne, L., & Cleeremans, A. (2012). Low hopes, high expectations expectancy effects and the replicability of behavioral experiments. *Perspectives on Psychological Science, 7*, 572–584.
- Knezović, Z., & Križanić, V. (2011). Croatian validation of PANAS-X. *Unpublished manuscript*.
- Krupić, D., Corr, P. J., Ručević, S., Križanić, V., & Gračanin, A. (2014). Reinforcement Sensitivity Theory (RST) of Personality Questionnaires: Comparison, Validity and Generalization. *In submission*.

- Lang, P. J., Bradley, M. M., & Cuthbert, B. N. (2008). *International affective picture system (IAPS): Affective ratings of pictures and instruction manual*. Technical Report A-8. University of Florida, Gainesville, FL.
- Larsen, R. J., & Ketelaar, T. (1991). Personality and susceptibility to positive and negative emotional states. *Journal of Personality and Social Psychology*, *61*, 132–140.
- Øktedalen, T., & Hagtvet, K. A. (2011). A revised version of the Norwegian Adaptation of the Test Anxiety Inventory in a heterogeneous population. *Scandinavian Journal of Educational Research*, *55*, 475–487.
- Pekrun, R., Elliot, A. J., & Maier, M. A. (2009). Achievement goals and achievement emotions: Testing a model of their joint relations with academic performance. *Journal of Educational Psychology*, *101*, 115–135.
- Pekrun, R., Goetz, T., Titz, W., & Perry, R. P. (2002). Academic emotions in students' self-regulated learning and achievement: A program of qualitative and quantitative research. *Educational Psychologist*, *37*, 95–105.
- Putwain, D. W., & Daniels, R. A. (2010). Is the relationship between competence beliefs and test anxiety influenced by goal orientation? *Learning and Individual Differences*, *20*, 8–13.
- Putwain, D. W., & Symes, W. (2012). Achievement goals as mediators of the relationship between competence beliefs and test anxiety. *British Journal of Educational Psychology*, *82*, 207–224.
- Putwain, D. W., Woods, K. A., & Symes, W. (2010). Personal and situational predictors of test anxiety of students in post-compulsory education. *British Journal of Educational Psychology*, *80*, 137–160.
- Sarason, I. G. (1969). Birth order, test anxiety, and learning. *Journal of Personality*, *37*, 171–177.
- Schaefer, A., Nils, F., Sanchez, X., & Philippot, P. (2010). Assessing the effectiveness of a large database of emotion-eliciting films: A new tool for emotion researchers. *Cognition and Emotion*, *24*, 1153–1172.
- Smillie, L. D., & Jackson, C. J. (2005). The appetitive motivation scale and other BAS measures in the prediction of approach and active avoidance. *Personality and Individual Differences*, *38*, 981–994.
- Stoeber, J., Feast, A. R., & Hayward, J. A. (2009). Self-oriented and socially prescribed perfectionism: Differential relationships with intrinsic and extrinsic motivation and test anxiety. *Personality and Individual Differences*, *47*, 423–428.

- Torrubia, R., Avila, C., Moltó, J., & Caseras, X. (2001). The Sensitivity to Punishment and Sensitivity to Reward Questionnaire (SPSRQ) as a measure of Gray's anxiety and impulsivity dimensions. *Personality and Individual Differences, 31*, 837–862.
- Wallbott, H. G., & Scherer, K. R. (1989). Assessing emotion by questionnaire. *Emotion: Theory, Research, and Experience, 4*, 55–82.
- Watson, D., Clark, L. A., & Tellegen, A. (1988). Development and validation of brief measures of positive and negative affect: The PANAS scales. *Journal of Personality and Social Psychology, 54*, 1063–1070.
- Živcic-Bečirević, I., Juretić, J., & Miljević, M. (2009). The role of metacognitive beliefs, automatic thoughts during learning and attribution of success in students' test anxiety and academic achievement. *Psychological Topics, 18*, 119–136.

7.4

High BAS and low BIS in overconfidence, and their impact on motivation and self-efficacy after feedback

Krupić, D. (2017)

Primenjena psihologija. 10(3), 297-312.

7.4. High BAS and low BIS in overconfidence, and their impact on motivation and self-efficacy after positive and negative performance

Self-confidence, motivation, and performance outcome are vital for goal-directed behaviour. However, people do not react to a positive and negative performance in the same way. This study examines (a) the relationship between self-confidence and approach/avoidance motivation, and (b) how approach- and avoidance-oriented individuals respond to a performance outcome. The study was conducted on 93 participants. The first part of the study examined the relationship between self-confidence and approach/avoidance motivation within RST, while the second part examined changes in motivation and self-efficacy in overconfident, avoidance- and approach-oriented individuals, following the positive and negative performance. Approach and avoidance tendencies were assessed by Reinforcement Sensitivity Questionnaire (RSQ) and Sensitivity to Punishment Sensitivity to Reward Questionnaire (SPSRQ). Correlational analysis showed that the Behavioural Approach System (BAS) and Sensitivity to Reward (SR) correlated positively, while Behavioural Inhibition System (BIS) and Sensitivity to Punishment (SP) correlated negatively with confidence. In addition, moderated regression analysis showed that (a) high BIS, SP and SR individuals were strongly demotivated following the negative performance, (b) while overconfident and high BAS individuals maintained their initial motivation. On the other hand, motivation in high SR, but not in the high BAS and overconfident individuals, increased after the positive performance. None of the scales predicted the change of self-efficacy either after the positive or negative performance. High BAS and low BIS in overconfident individuals may explain why they strive more toward the final goal despite drawbacks. The theoretical and practical implications of findings are discussed in the paper.

Keywords: Reinforcement Sensitivity Theory, motivation, self-efficacy, performance, experiment

1. Introduction

Important goals are often complex ones. To accomplish them, one can face with potential drawbacks and obstacles. The way how one cope with these drawbacks, may have a crucial importance for the outcome. This paper examines the role of approach and avoidance motivation in overconfidence, and their impact on self-efficacy and motivation after a positive and negative performance.

1.1. Overconfidence

Overconfidence manifests in three ways. First, overestimation is the case of overconfidence when one predicts greater success or performance in a task than one truly achieves. Overplacement is the second case of overconfidence, when one mistakenly believes that he or she will perform better than the others will. Finally, overprecision manifests in giving overly precise prognoses of the future events (Moore & Healy, 2008; Williams & Gilovich, 2008).

Overconfidence and its impact on the economy have been extensively studied in the context of managerial decision-making processes. For example, Patel and Cooper (2014) have found that overconfident CEOs are more driven by potential gains and less by avoiding potential losses, which may enhance the recovery of firms in the post-crisis period (Kilduff & Galinsky, 2013), but might be fatal during the crises (Foster, Reidy, Misra, & Goff, 2011). Further, overconfident individuals tend to have higher aspiration for a high social status (Anderson, Brion, Moore, & Kennedy, 2012). They are more risk-prone and entrepreneurship-oriented (e.g. Malmendier & Tate, 2005; Sadi, Asl, Rostami, Gholipour, & Gholipour, 2011), attracted by external motives (Sheldon, Gunz, Nichols, & Ferguson, 2010). At the same time they work less (Stone, 1994), and make more mistakes, which often result in poorer performance (Dunlosky & Rawson, 2012; Miller & Geraci, 2011). On the top of that, their overconfidence is highly persistent (e.g. Grossman & Owens, 2012). For example, Chen, Crossland, and Luo (2015) showed that overconfident CEOs are not willing to correct projections of corporate earnings after previously poor forecasting. Such individuals show the tendency to keep the same level of optimism (and act accordingly) notwithstanding previous poor performance.

The key question is how (and why) overconfident individuals persevere in achieving the final goal, despite the higher rate of experiencing a negative performance? This is an important issue, especially since it seems that this makes them more successful in a long run

(Anderson et al., 2012), and that such individuals are usually those whose decisions have a strong impact on society (e.g. corporate CEOs, policy makers, etc.). Moreover, it seems that overconfidence of people in power is inevitable, since the position of power itself makes people overconfident (see for details Guinote, 2017).

Overconfident individuals perceive themselves as more open and extraverted (Buratti & Allwood, 2012; Sadi et al., 2011), proactive (Pallier et al., 2002), and, what was the most frequently studied, they appear to be narcissistic (Campbell, Goodie, & Foster, 2004). Just as overconfident individuals, narcissistic individuals are highly motivated by positive reinforcers, and weakly motivated by negative reinforcers (Foster & Trimm, 2008). In addition, many studies have shown that narcissism correlates positively with approach, and negatively with avoidance motivation (Foster & Brennan, 2012). Thus, the case of narcissism implies that overconfidence might be explained within the approach/avoidance motivation, which has not yet been empirically examined, and therefore presents the aim of this study.

1.2. Reinforcement sensitivity theory

One of the most prominent approach/avoidance theories, Reinforcement Sensitivity Theory (RST), postulates three brain-behavioural circuits that represent general emotion-motivational systems. Behavioural approach system (BAS) mediates all appetitive motives, and in evolutionary terms, it represents the resource acquisition mechanism. The Fight-Flight-Freeze System (FFFS) serves as a defensive mechanism important for survival, being triggered by life-threatening situations. At the end, Behavioural Inhibition System (BIS) acts as a conflict resolution mechanism in ambiguous situations when both the BAS and the FFFS are active. It elevates the level of anxiety, which urges an individual to choose between approaching to and escaping from the conflicting stimulus (Corr, 2008; Gray & McNaughton, 2003).

The aim of this study is to examine whether the BAS and the BIS may explain overconfidence. Although the FFFS along with the BIS represents the avoidance mechanism, its functions are more important in the life-threatening situations, while the BIS is more important in dealing with daily stressors. Thus, the FFFS is not discussed in this study. The first hypothesis is that confidence should positively correlate with the BAS, and negatively with the BIS. This is expected since narcissism correlates positively to overconfidence (e.g. Campbell et al., 2004) and approach, whereas it correlates negatively to avoidance motivation (Foster & Brennan, 2012). The second hypothesis is that the confidence and the BAS should positively predict the number of mistakes, while the BIS negatively predicts the number of mistakes, what

is found in overconfident (e.g. Dunlowsky & Rawson, 2012), narcissistic (e.g. Campbell et al., 2004), and high BAS and low BIS individuals (Kim & Lee, 2011). Third, overconfident and high BAS individuals should maintain motivation and self-efficacy after a negative feedback, what is found in overconfident individuals (e.g. Grossman & Owens, 2012). In addition, Kim and Lee (2011) in their gambling study have found that (a) low BAS and high BIS individuals make less risky decisions after a losing condition, whereas in the same condition (b) high BAS individuals bet larger amounts. On the contrary, high BIS individuals experience higher negative affect following the negative performance (Ilies, Judge, & Wagner, 2010; Krupić & Corr, 2014), which may decrease their self-efficiency. Hence, high BIS individuals should be less motivated and should feel less self-efficient after the negative performance.

Overview of the study

This study focuses on the overestimation type of overconfidence, measured by subtracting obtained score from the expected one. However, some task-characteristics in a study of overconfidence can bias interpretation of the data. First, the answer format may bias the estimate (Loftus, 1975). Hence, participants' estimation of performance score will be assessed by an open-ended question format. Secondly, the outcome of the task depends on the difficulty and complexity of the task (Klayman & Soll, 1999; Larrick, Burson, & Soll, 2007). However, this issue is more relevant for experimental designs examining overconfidence across tasks/domains, but in a study of individual differences in overconfidence, it is important that all participants are observed in the same conditions, i.e. by the same task.

The hypotheses will be examined by two behavioural tasks. The first task will test the first two hypotheses predicting that the BAS would positively predict the number of mistakes, while the BIS would negatively correlate with overconfidence and with the number of mistakes. The second task examines the role of the confidence (obtained by the first task), and the BAS and the BIS on the effects of positive and negative performance on motivation and self-efficacy. Finally, due to the existence of several competing RST questionnaires (Corr, 2016), two brief RST questionnaires will be used to improve the generalisability of the findings.

2. Method

2.1. Participants

In exchange for the experimental hours, 97 Psychology students in the age range from 19 to 29 ($M = 20.01$, $SD = 1.39$) participated in two serial tasks. Since there were only four male participants in the study, their data were not analysed, which reduced the final sample to 93.

2.2. Instruments

Sensitivity to Punishment and Sensitivity to Reward Questionnaire 20 (SPSRQ-20: Aluja & Blanch, 2011). SPSRQ-20 is a 20-dichotomous-item version of the SPSRQ (Torrubia, Avila, Molto, & Cesares, 2001). It contains two 10-item scales – Sensitivity to Punishment (SP) and Sensitivity to Reward (SR).

Reinforcement Sensitivity Questionnaire (RSQ: Smederevac, Mitrović, Čolović, & Nikolašević, 2014). RSQ is a 29-item questionnaire that contains five scales – Behavioural Approach System (BAS), Behavioural Inhibition System (BIS), Fight, Flight, and Freezing. Items are answered on a four-point Likert-type scale.

Both questionnaires are validated in Croatian language (Krupić, Corr, Ručević, Križanić, & Gračanin, 2016).

2.3. Procedure

Behavioural tasks and personality data were obtained independently. First, participants fulfilled personality questionnaires. A few days later, they enrolled in the first task labelled Throwing disks, and later in the second task labelled Learning labyrinth. The score of confidence from the Throwing disks task was used as the predictor of motivation and self-efficacy after the performance in Learning labyrinth task. The relationship between personality traits and behavioural tasks were not explained to the participants in order to keep them unaware of the hypotheses. All measurements were conducted individually. After the data collection, all participants were thanked and fully debriefed. In order to assure that the participants were hypothesis-naïve during measurement, they were asked for the purpose of the study during the debriefing after the measurement. In general, the implicit hypotheses may inflate an error variance, and therefore increase the chance of the Type II error, while knowing the hypothesis may increase the Type I error. Since none of the participants saw the connection between personality data and two behavioural tasks, the results of this study are more likely under influence of Type II error rather than Type I.

Throwing disks. In the first behavioural task, participants had to hit the target with DVD disks from ten equidistant places. The nearest place was 30 cm, while the most distant place were 3 m away from the target. The target, which was of four A4 format papers, was placed on the floor. Participants had ten throws, and were instructed to collect as many points as possible. During the throwing phase, they could change their distances, i.e. move closer or away from the target. Points were coded according to the distance from which the participant had hit the target, while misses were coded by zero. Hence, the lowest possible score was 0 (if the participant had all ten misses), and the highest 100 (if the participant hit the target ten times from the farthest distance), which was explained to the participants. Before the throwing phase, the participants had to estimate the amount of points which they expected to collect (i.e. an expected score). The number of hits, chosen distances, and points were recorded by the experimenter, while the level of confidence was calculated by subtracting the expected minus from the obtained score. The measurement was conducted individually, and it lasted from five to ten minutes per participant.

Learning labyrinth. The measurement was also conducted individually, and lasted from 15 to 45 minutes, depending on the participant's performance. At the beginning of the task, the participants were blindfolded, and guided to the table with the hand-maze or labyrinth. They were informed that the labyrinth-learning phase was limited to 30 attempts. The labyrinth was considered as learned if the participant underwent the labyrinth twice in a row without a mistake (entering into the blind alley). After the instruction, and just before the first attempt of learning the labyrinth, the participants were asked to rate their motivation ("Rate your motivation for the task on a scale from 1 = Completely unmotivated to 10 = Highly motivated") and self-efficacy ("Having in mind that you have a total of 30 attempts to learn the labyrinth, can you predict how many attempts will it take until you learn the labyrinth?"). If the participant reached the 30th attempt of learning, the learning was stopped, and the participant was informed that he/she did not learn the labyrinth (negative performance). Otherwise, he/she was informed that the labyrinth was learned successfully (positive performance). Afterwards, still blindfolded participants were told that they learnt the second labyrinth, and they were asked the same two questions from the beginning of the task (motivation₂ and self-efficacy₂). When the participant answered these questions, the measurement was stopped, and the participant was thanked and debriefed. The change in motivation (Δ Motivation) and self-efficacy (Δ Self-efficacy) was calculated by subtracting motivation₂ – motivation₁ and self-efficacy₂ – self-efficacy₁, respectively. In order to rule out the potential role of the experimenter's gender, and minimise the social desirable responding, experimental demands, and expectancies, this task was

conducted by female psychology students for the experimental hours. They were instructed how to conduct the measurement, but the same as participants, they were not aware of the hypotheses of the study. The Ethical Board of the Department of Psychology in Rijeka, Croatia, gave the consent for the study.

3. Results

The BAS and SR correlated positively, and the BIS and SP correlated negatively with confidence, what supported the first hypothesis. In addition, confidence and the BIS, but not the BAS, SR and SP, predicted the number of hits, in the first task (Table 1). This indicated that overconfident had more misses, while the high BIS individuals had fewer misses. Also, as it could be seen from the table, confidence and the BAS correlated positively, and the BIS correlated negatively with the average distance from which the participants were aiming the target.

In the second task, two separate mixed ANOVAs were conducted to test the effects of performance on motivation and self-efficacy. Forty-five students performed successfully, and forty-eight students were not successful, indicating that this task was moderately difficult. An average number of learning attempts in the successful group was 14.75 ($SD = 6.78$). Box's test of equality of covariance matrices was not significant at $p < .05$ in either case. Since the main effects were not informative, only interactions were reported. Interactions were significant for motivation ($F(1, 77) = 11.03, p < .01, \eta^2 = .13$) and for self-efficacy ($F(1, 77) = 7.83, p < .01, \eta^2 = .09$). The Figure 1 shows that the negative performance decreased motivation and self-efficacy (which is seen in the increase of estimated attempts for learning the new labyrinth), while the positive performance produced no effects.

The role of personality and confidence (obtained in the Throwing disks task) in changing motivation (Δ Motivation) and self-efficiency (Δ Self-efficacy) after the performance was tested by moderated regression analysis, where the performance was treated as a dichotomous moderator variable. The BIS, SP, SR, and confidence were found to interact with performance on motivation, while there were no significant interactions concerning the self-efficacy (Table 2). Interactions concerning only motivation are presented in Figure 2. The results showed that the high SR (but not the BAS) students were more motivated for the next task following the positive performance. In line with the third hypothesis, the BIS correlated negatively, and confidence correlated positively with motivation after the negative

performance, while no effects were found for the BAS. In addition, the interaction of the BAS and BIS in correspondence to the performance outcome was not significant.

Table 1

Descriptive statistics, Pearson's correlation coefficients for “throwing disk” behavioural tasks and personality traits

	α	M	SD	Over-confidence	Expected result	Total score	Number of hits	Average distance
Confidence		7.73	15.29	-	-	-	-.52**	.25*
RSQ								
BAS	.77	15.97	3.34	.39**(.44)	.40**(.46)	-.12(-.14)	-.22(-.25)	.30**(.34)
BIS	.74	17.21	3.78	-.27*(-.31)	-.24*(-.28)	.15(.17)	.26*(.30)	-.35**(-.40)
SPSRQ-20								
SP	.73	4.81	2.60	-.24*(-.28)	-.29*(-.34)	.00(.00)	.08(.09)	-.22(-.26)
SR	.62	4.48	2.02	.36**(.46)	.38**(.48)	-.09(-.11)	-.05(-.06)	.10(.13)

Note. Correlation coefficients corrected for attenuation in brackets. M = arithmetic mean; SD = standard deviation; BAS = Behavioural Approach System; BIS = Behavioural Inhibition System; SP = Sensitivity to Punishment; SR = Sensitivity to Reward.

* $p < .05$. ** $p < .01$.

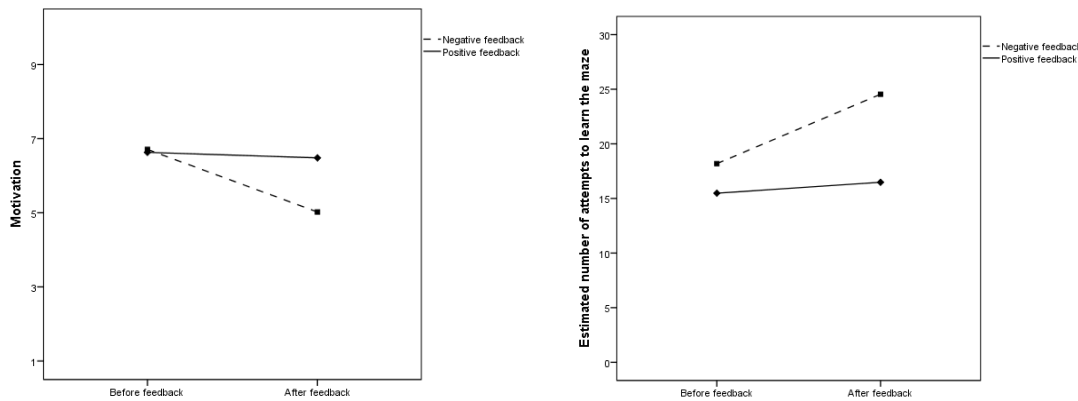

Figure 1. Arithmetic means of motivation and self-efficacy in two measurement point.

Table 2

Moderated regression analyses for RST scales in predicting changes in motivation after the positive and negative performance

	RSQ				SPSRQ-20		
	β	SE	<i>t</i>		β	SE	<i>t</i>
Constant	-0.73**	0.19	-3.92	Constant	-	0.18	-4.84
BAS	-0.04	0.06	-0.80	SR	-0.06	0.09	-0.67
BIS	-0.1	0.06	-1.76	SP	-0.08	0.07	-1.22
BIS X BAS	0.02	0.01	1.70	SP X SR	-0.02	0.03	-0.58
Performance	1.49**	0.37	4.01	Performance	1.71**	0.36	4.79
BIS X Performance	0.25*	0.11	2.26	SP X Performance	0.28*	0.13	2.15
BAS X Performance	0.08	0.11	0.76	SR X Performance	0.46*	0.19	2.46
BIS X BAS X Performance	-0.02	0.03	-0.64	SP X SR X Performance	0.00	0.07	-0.02
<i>R</i> = .58				<i>R</i> = .56			
<i>R</i> ² = .33				<i>R</i> ² = .31			
<i>F</i> (7, 82) = 5.25**				<i>F</i> (7, 83) = 4.88**			

Note. β = unstandardized beta coefficient; Performance = negative performance coded by 0, and positive by 1; BAS = Behavioural Approach System; BIS = Behavioural Inhibition System; SP = Sensitivity to Punishment; SR = Sensitivity to Reward.

* $p < .05$. ** $p < .01$.

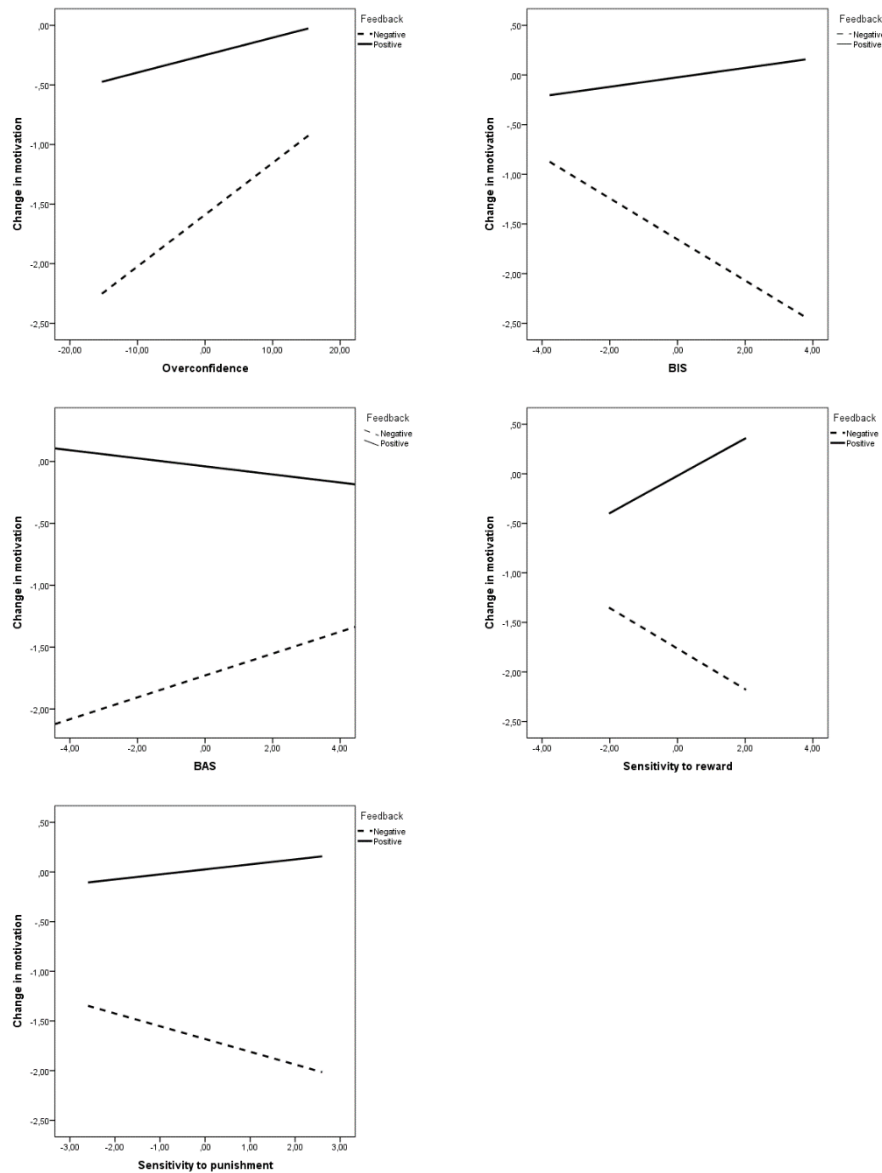

Figure 2. Role of individual differences in predicting change in motivation after the positive and negative performance.

4. Discussion

The aim of this study was to examine the relationship between individual differences in the activity of brain-behavioural systems (the BAS and the BIS) and confidence, as well as to examine the role of these individual differences in changing motivation and self-efficacy after the positive and negative performance.

This study has confirmed earlier findings, obtained from a real-world studies exploring e.g. corporate investment decision-making (e.g. Barber & Odean, 2000), that the overconfident

individuals make more mistakes and take higher risks. These findings have been confirmed in this study by laboratory tasks with no real reinforcement, which evidence the ecological validity of the results. Furthermore, the BAS/SR and the BIS/SP correlated with overconfidence, whereas only the BIS correlated with the number of misses as predicted in the first hypothesis. The BAS did not achieve significant correlation to the number of hits, but it correlated with other aspects of overconfidence. Namely, the high BAS individuals had higher expectations, and were ready to risk more. Reasonably, due to higher average distance in the throwing disks task, overconfident individuals had more misses, while the high BIS individuals performed the opposite. An additional analysis, which was not provided in the result section, revealed that the overconfidence was not the result of mutually effects of the BAS/BIS or the SR/SP, predicted by the joint subsystem hypothesis.

In the second task, the high SR, but not the BAS, individuals reported the increase in motivation following the positive performance, while motivation of the high BIS (anxious) individuals remained the same. When faced with the negative performance, the anxious individuals tended to be more demotivated, while motivation in the high BAS individuals remained approximately the same. As expected, the overconfident individuals tended to increase their motivation after the negative performance, what might increase their chances for the success in a long run. As it could be seen from the Figure 2, the high BAS individuals tended to display a similar pattern, but the effect was not strong enough to achieve the significance level.

To summarise the key findings of this study, data suggest that the high BAS and the low BIS in overconfident individuals may explain their persistence after the negative performance.

How to explain the divergent findings between the BAS and SR, the scales designed to measure the same construct? Currently, there are several competing RST questionnaires (for more details see Corr, 2016), which complicate the interpretation of the data. Krupić, Corr and associates (2016) have found that the RST questionnaires differ in operationalisation of the BAS, which may bias the interpretation of the findings about the core features of RST dimensions (for example see Krupić, Gračanin, & Corr, 2016). The BAS from RSQ reflects the incentive motivation part, while the SR reflects the wanting part of the reward system. In the recent article, Krupić and Corr (2017) argue that these scales may reflect activities of different biological factors. Specifically, the BAS scale from the RSQ (reflecting incentive motivation) is related to the activities of dopaminergic system, while the SR (reflecting the wanting part of the reward system) is related to testosterone (for details see Krupić & Corr, 2017). Hence,

distinct predictions of the SR and BAS scales may reflect activities of different aspects of the approach motivation.

The finding that the high SR individuals are more motivated following the positive performance while the high BIS individuals are less motivated after the negative performance, is in accordance with the original version of RST, upon which the SPSRQ has been designed. The results of the SR are in line with the findings of the increased levels of testosterone after reward (Stanton, Beehner, Saini, Kuhn, & LaBar, 2009), reflecting the extrinsic motivation. On the contrary, the BAS and overconfidence have achieved almost the opposite effects, which could be explained within the goal orientation theory. Namely, a general task orientation includes a number of related beliefs about the purposes, competence, success, ability, effort, errors, and standards (Pintrich, 2000). Dweck and Elliot (1983) distinguish performance and learning goal-orientations. Individuals concerned by gaining favourable judgments on their competence are focused on the performance goals, while individuals focused on improving competences are focused on learning (mastery) goals. Later, Elliot and McGregor (2001) have introduced the extended 2×2 framework of purpose goals, covering: (a) mastery-approach goals – learning and achieving personal growth; (b) performance-approach goals – motivation to outperform others; (c) mastery-avoidance goals – avoiding deterioration or losing skills; (d) performance-avoidance goals – avoiding failure and looking incompetent (Elliot, 1999; Senko, Hulleman, & Harackiewicz, 2011). Elliot and Thrash (2002) argue that learning goal-orientation mediates the temperamental traits in the prediction of education-related outcomes, where the BAS positively correlates with mastery-approach goals, and the BIS positively correlates with mastery and performance avoidance-goals (Bjørnebekk, 2007; Elliot & Thrash, 2002). There are no changes in motivation and self-efficacy in the high BAS and overconfident individuals after the positive performance, and a slight increase of both after negative performance is typical for individuals adopting mastery approach goal orientation. Such individuals seek for new and challenging tasks (Senko et al., 2011), and persist in tasks after a negative feedback (Sideridis & Kaplan, 2011). Thus, it is most likely that the high BAS, but not SR, individuals adopt more mastery approach goal-orientation, something that should be empirically examined in the future studies.

Before conclusion, it is important to emphasise that this study was conducted on relatively small and non-representative sample. In the light of these limitations, the contribution of this study should be seen in presenting a promising avenue for the research in RST, especially in the field of motivation (see Corr & Krupić, 2017). Nevertheless, the study was conducted in the manner to favour Type II error. First, data for personality and both behavioural tasks were

obtained separately, which reduced the measurement error that could artificially inflate the correlations between variables measured at the same time and place (see Podsakoff, McKenzie, Lee, & Podsakoff, 2003). Secondly, variables in behavioural task represented single item measure, which reduced variability and reliability, and therefore attenuated correlations between variables. Thereby, despite the higher level of Type II error, significant and, in some cases, moderate correlations present a strong argument that observed effects truly exist, and could be the most likely replicated in the future studies.

To sum up, approach and avoidance motivation play an important role in overconfidence. Furthermore, the negative performance has a stronger negative effect on motivation in anxious individuals, but not in approach-oriented individuals, which is important in accomplishing complex and/or long-term goals. According to this study, the anxious individuals would benefit if the complex task is decomposed into a number of less difficult subtasks, which would lower their chance of the negative performance, while for the high BAS and overconfident individuals challenging tasks may have positive effects on their motivation.

5. References

- Aluja, A., & Blanch, A. (2011). Neuropsychological behavioral inhibition system (BIS) and behavioral approach system (BAS) assessment: A shortened sensitivity to punishment and sensitivity to reward questionnaire version (SPSRQ-20). *Journal of Personality Assessment, 93*, 628–636. [doi:10.1080/00223891.2011.608760](https://doi.org/10.1080/00223891.2011.608760)
- Anderson, C., Brion, S., Moore, D. A., & Kennedy, J. A. (2012). A status-enhancement account of overconfidence. *Journal of Personality and Social Psychology, 103*, 718–735. [doi:10.1037/a0029395](https://doi.org/10.1037/a0029395)
- Barber, B. M., & Odean, T. (2000). Trading is hazardous to your wealth: The common stock investment performance of individual investors. *The Journal of Finance, 55*, 773–806. [doi:10.2139/ssrn.219228](https://doi.org/10.2139/ssrn.219228)
- Bjørnebekk, G. (2007). Reinforcement sensitivity theory and major motivational and self-regulatory processes in children. *Personality and Individual Differences, 43*, 1980–1990. [doi:10.1016/j.paid.2007.06.010](https://doi.org/10.1016/j.paid.2007.06.010)

- Buratti, S., & Allwood, C. (2012). Improved realism of confidence for an episodic memory event. *Judgment and Decision Making*, 7, 590–601. Retrieved from <http://journal.sjdm.org/11/111121a/jdm111121a.html>
- Campbell, W. K., Goodie, A. S., & Foster, J. D. (2004). Narcissism, confidence, and risk attitude. *Journal of Behavioral Decision Making*, 17, 297–311. [doi:10.1002/bdm.475](https://doi.org/10.1002/bdm.475)
- Chen, G., Crossland, C., & Luo, S. (2015). Making the same mistake all over again: CEO overconfidence and corporate resistance to corrective feedback. *Strategic Management Journal*, 36, 1513–1535. [doi:10.1002/smj.2291](https://doi.org/10.1002/smj.2291)
- Corr, P. J. (2008). Reinforcement sensitivity theory (RST): Introduction. In P. J. Corr (Ed.), *The reinforcement sensitivity theory and personality* (pp. 1–28). Cambridge: Cambridge University Press. [doi:10.1017/CBO9780511819384.002](https://doi.org/10.1017/CBO9780511819384.002)
- Corr, P. J. (2016). Reinforcement Sensitivity Theory of Personality Questionnaires: Structural survey with recommendations. *Personality and Individual Differences*, 89, 60–64. [doi:10.1016/j.paid.2015.09.045](https://doi.org/10.1016/j.paid.2015.09.045)
- Corr, P. J., & Krupić, D. (2017). Motivating personality: Approach, avoidance, and their conflict. In A. Elliot (Ed.), *Advances in Motivation Science*, Volume 4 (pp. 39-90). London: Elsevier. <http://dx.doi.org/10.1016/bs.adms.2017.02.003>
- Dunlosky, J., & Rawson, K. A. (2012). Overconfidence produces underachievement: Inaccurate self evaluations undermine students' learning and retention. *Learning and Instruction*, 22, 271–280. [doi:10.1016/j.learninstruc.2011.08.003](https://doi.org/10.1016/j.learninstruc.2011.08.003)
- Dweck, C. S., & Elliott, E. S. (1983). Achievement motivation. In P. Mussen, & E. M. Hetherington (Ed.), *Handbook of Child Psychology: Socialisation, Personality and Social Development* (Vol. 4, pp. 643–691). New York: Wiley. [doi:10.1016/B978-0-12-373951-3.00002-8](https://doi.org/10.1016/B978-0-12-373951-3.00002-8)
- Elliot, A. J. (1999). Approach and avoidance motivation and achievement goals. *Educational Psychologist*, 34, 169–189. [doi:10.1207/s15326985ep3403](https://doi.org/10.1207/s15326985ep3403)
- Elliot, A. J., & McGregor, H. A. (2001). A 2×2 achievement goal framework. *Journal of Personality and Social Psychology*, 80, 501–519. [doi:10.1037/0022-3514.80.3.501](https://doi.org/10.1037/0022-3514.80.3.501)

- Elliot, A. J., & Thrash, T. M. (2002). Approach-avoidance motivation in personality: Approach and avoidance temperaments and goals. *Journal of Personality and Social Psychology*, 82, 804–818. [doi:10.1037/0022-3514.82.5.804](https://doi.org/10.1037/0022-3514.82.5.804)
- Foster, J. D., & Brennan, J. C. (2012). Narcissism, the agency model, and approach-avoidance motivation. In W. K., Campbell & J. D., Miller (Eds.), *The handbook of narcissism and narcissistic personality disorder: Theoretical approaches, empirical findings, and treatments* (pp. 89–100). Hoboken, NJ: John Wiley & Sons Inc. [doi:10.1002/9781118093108.ch8](https://doi.org/10.1002/9781118093108.ch8)
- Foster, J. D., & Trimm, R. F. (2008). On being eager and uninhibited: Narcissism and approach-avoidance motivation. *Personality and Social Psychology Bulletin*, 34, 1004–1017. [doi:10.1177/0146167208316688](https://doi.org/10.1177/0146167208316688)
- Foster, J. D., Reidy, D. E., Misra, T. A., & Goff, J. S. (2011). Narcissism and stock market investing: Correlates and consequences of cocksure investing. *Personality and Individual Differences*, 50, 816–821. [doi:10.1016/j.paid.2011.01.002](https://doi.org/10.1016/j.paid.2011.01.002)
- Gray, J. A., & McNaughton, N. (2003). *The neuropsychology of anxiety: An enquiry into the function of the septo-hippocampal system* (No. 33). Oxford: Oxford University Press. <http://dx.doi.org/10.1093/acprof:oso/9780198522713.001.0001>
- Grossman, Z., & Owens, D. (2012). An unlucky feeling: Overconfidence and noisy feedback. *Journal of Economic Behavior & Organization*, 84, 510–524. <http://dx.doi.org/10.1016/j.jebo.2012.08.006>
- Guinote, A. (2017). How power affects people: Activating, wanting, and goal seeking. *Annual Review of Psychology*, 68, 353–381. [doi:10.1146/annurev-psych-010416-044153](https://doi.org/10.1146/annurev-psych-010416-044153)
- Ilies, R., Judge, T. A., & Wagner, D. T. (2010). The influence of cognitive and affective reactions to feedback on subsequent goals. *European Psychologist*, 15, 121–131. <http://dx.doi.org/10.1027/1016-9040/a000011>
- Kilduff, G. J., & Galinsky, A. D. (2013). From the ephemeral to the enduring: How approach-oriented mindsets lead to greater status. *Journal of Personality and Social Psychology*, 105, 816–831. [doi:10.1037/a0033667](https://doi.org/10.1037/a0033667)

- Kim, D. Y., & Lee, J. H. (2011). Effects of the BAS and BIS on decision-making in a gambling task. *Personality and Individual Differences, 50*, 1131–1135.
[doi:10.1016/j.paid.2011.01.041](https://doi.org/10.1016/j.paid.2011.01.041)
- Klayman, J., & Soll, J. (1999). Overconfidence: It depends on how, what, and whom you ask. *Organizational Behavior and Human Decision Processes, 79*, 216–247.
<http://dx.doi.org/10.1006/obhd.1999.2847>
- Krupić, D., & Corr, P. J. (2017). Moving forward with the BAS: Toward neurobiology of multidimensional model of approach motivation. *Manuscript submitted for publication*.
- Krupić, D., & Corr, P. J. (2014). Individual differences in emotion elicitation in university examinations: A quasi-experimental study. *Personality and Individual Differences, 71*, 176–180. [doi:10.1016/j.paid.2014.08.001](https://doi.org/10.1016/j.paid.2014.08.001)
- Krupić, D., Corr, P. J., Ručević, S., Križanić, V., & Gračanin, A. (2016). Five Reinforcement Sensitivity Theory (RST) of personality questionnaires: Comparison, validity, and generalization. *Personality and Individual Differences, 97*, 19–24.
[doi:10.1016/j.paid.2016.03.012](https://doi.org/10.1016/j.paid.2016.03.012)
- Krupić, D., Gračanin, A., & Corr, P. J. (2016). The evolution of the Behavioural Approach System (BAS): Cooperative and competitive resource acquisition strategies. *Personality and Individual Differences, 94*, 223–227. [doi:10.1016/j.paid.2016.01.044](https://doi.org/10.1016/j.paid.2016.01.044)
- Larrick, R. P., Burson, K. A., & Soll, J. B. (2007). Social comparison and confidence: When thinking you're better than average predicts overconfidence (and when it does not). *Organizational Behavior and Human Decision Processes, 102*, 76–94.
[doi:10.1016/j.obhdp.2006.10.002](https://doi.org/10.1016/j.obhdp.2006.10.002)
- Loftus, E. F. (1975). Leading questions and the eyewitness report. *Cognitive Psychology, 7*, 560–572. [doi:10.1016/0010-0285\(75\)90023-7](https://doi.org/10.1016/0010-0285(75)90023-7)
- Malmendier, U., & Tate, G. (2005). Does overconfidence affect corporate investment? CEO overconfidence measures revisited. *European Financial Management, 11*, 649–659.
[doi:10.1111/j.1354-7798.2005.00302.x](https://doi.org/10.1111/j.1354-7798.2005.00302.x)

- Miller, T. M., & Geraci, L. (2011). Unskilled but aware: Reinterpreting overconfidence in low-performing students. *Journal of Experimental Psychology. Learning, Memory, and Cognition*, *37*, 502–506. [doi:10.1037/a0021802](https://doi.org/10.1037/a0021802)
- Moore, D. A., & Healy, P. J. (2008). The trouble with overconfidence. *Psychological Review*, *115*, 502–517. [doi:10.1037/0033-295X.115.2.502](https://doi.org/10.1037/0033-295X.115.2.502)
- Pallier, G., Wilkinson, R., Danthiir, V., Kleitman, S., Knezevic, G., Stankov, L., & Roberts, R. D. (2002). The role of individual differences in the accuracy of confidence judgments. *Journal of General Psychology*, *129*, 257–299. [doi:10.1080/00221300209602099](https://doi.org/10.1080/00221300209602099)
- Patel, P. C., & Cooper, D. (2014). The harder they fall, the faster they rise: Approach and avoidance focus in narcissistic CEOs. *Strategic Management Journal*, *35*, 1528–1540. [doi:10.1002/smj.2162](https://doi.org/10.1002/smj.2162)
- Pintrich, P. (2000). An achievement goal theory perspective on issues in motivation terminology, theory, and research. *Contemporary Educational Psychology*, *25*, 92–104. [doi:10.1006/ceps.1999.1017](https://doi.org/10.1006/ceps.1999.1017)
- Podsakoff, P. M., MacKenzie, S. B., Lee, J. Y., & Podsakoff, N. P. (2003). Common method biases in behavioral research: A critical review of the literature and recommended remedies. *Journal of Applied Psychology*, *88*, 879–903. <http://dx.doi.org/10.1037/0021-9010.88.5.879>
- Sadi, R., Asl, H. G., Rostami, M. R., Gholipour, A., & Gholipour, F. (2011). Behavioral finance: The explanation of investors' personality and perceptual biases effects on financial decisions. *International Journal of Economics and Finance*, *3*, 234–241. [doi:10.5539/ijef.v3n5p234](https://doi.org/10.5539/ijef.v3n5p234)
- Senko, C., Hulleman, C. S., & Harackiewicz, J. M. (2011). Achievement goal theory at the crossroads: Old controversies, current challenges, and new directions. *Educational Psychologist*, *46*, 26–47. [doi:10.1080/00461520.2011.538646](https://doi.org/10.1080/00461520.2011.538646)

- Sheldon, K. M., Gunz, A., Nichols, C. P., & Ferguson, Y. (2010). Extrinsic value orientation and affective forecasting: Overestimating the rewards, underestimating the costs. *Journal of Personality*, 78, 149–178. [doi:10.1111/j.1467-6494.2009.00612.x](https://doi.org/10.1111/j.1467-6494.2009.00612.x)
- Sideridis, G. D., & Kaplan, A. (2011). Achievement goals and persistence across tasks: The roles of failure and success. *The Journal of Experimental Education*, 79, 429–451. [doi:10.1080/00220973.2010.539634](https://doi.org/10.1080/00220973.2010.539634)
- Smederevac, S., Mitrović, D., Čolović, P., & Nikolašević, Ž. (2014). Validation of the measure of Revised Reinforcement Sensitivity Theory constructs. *Journal of Individual Differences*, 35, 12–21. [doi:10.1027/1614-0001/a000121](https://doi.org/10.1027/1614-0001/a000121)
- Stanton, S. J., Beehner, J. C., Saini, E. K., Kuhn, C. M., & LaBar, K. S. (2009). Dominance, politics, and physiology: Voters' testosterone changes on the night of the 2008 United States presidential election. *PLoS One*, 4, e7543. <http://dx.doi.org/10.1371/journal.pone.0007543>
- Stone, D. N. (1994). Overconfidence in initial self-efficacy judgments: Effects on decision processes and performance. *Organizational Behavior and Human Decision Processes*, 59, 452–474. [doi:10.1006/obhd.1994.1069](https://doi.org/10.1006/obhd.1994.1069)
- Torrubia, R., Avila, C., Moltó, J., & Caseras, X. (2001). The Sensitivity to Punishment and Sensitivity to Reward Questionnaire (SPSRQ) as a measure of Gray's anxiety and impulsivity dimensions. *Personality and Individual Differences*, 31, 837–862. [doi:10.1016/S0191-8869\(00\)00183-5](https://doi.org/10.1016/S0191-8869(00)00183-5)
- Williams, E. F., & Gilovich, T. (2008). Do people really believe they are above average? *Journal of Experimental Social Psychology*, 44, 1121–1128. [doi:10.1016/j.jesp.2008.01.002](https://doi.org/10.1016/j.jesp.2008.01.002)

7.5

The evolution of the Behavioural Approach System (BAS): Cooperative and competitive resource acquisition strategies.

Krupić, D., Gračanin, A., & Corr, P.J. (2016).

Personality and Individual Differences, 94, 223-227.

7.5. The evolution of the Behavioural Approach System (BAS): Cooperative and competitive resource acquisition strategies

Abstract

The nature of approach motivation has not yet been adequately defined. Some authors view it as a unidimensional construct, while others consider it to be multidimensional. Its psychometric nature is explored in this study, which tests empirically the motivational account of the Behavioural Approach System (BAS) within an evolutionary context. In a sample of 394 participants, we administered the Assessment of Individual Motives questionnaire (AIM-Q), the Reinforcement Sensitivity Theory Personality Questionnaire (RST-PQ) and a short version of the Sensitivity to Punishment and Sensitivity to Reward (SPSRQ-20). The results of set correlation analysis indicated that different BAS scales relate to different motives, thus supporting the multidimensional perspective on approach motivation. Specifically, Reward Interest relates to various types of motives that generally reflect sensitivity to social rewards; Goal-Drive Persistence relates to social exchange; Reward reactivity to safety and commitment; while Impulsivity and Sensitivity to Reward (SR) relate to competitive motives. These results are discussed within an evolutionary framework for the multidimensionality of the BAS.

Keywords: Reinforcement sensitivity theory, Motivation, Personality, Evolution, Set correlation analysis

1. Introduction

The Behavioural Approach System (BAS) is one of the three major systems in the neuropsychological theory of personality known as the reinforcement sensitivity theory (RST), which includes two additional defensive systems: the Fight–Flight–Freeze System (FFFS), responsible for the active avoidance of, and escape from, aversive stimuli; and the Behavioural Inhibition System (BIS), responsible for passive avoidance and the detection and resolution of goal-conflict. It is assumed that the BAS represents a general domain approach mechanism designed to solve the important evolutionary adaptive problem of attaining critical resources, such as food, water, sex and social status (Berridge, 2004; Berridge & Robinson, 2003; Kenrick

& Shiota, 2008). In general terms, the BAS mediates reactions to reward and non-punishment. Its outputs serve to motivate approach behaviours toward biological reinforcers and to engage in activities that lead to consummatory behaviour (Corr, 2008; Gray & McNaughton, 2000). Despite the popularity and long history of this theory, the obvious evolutionary importance of the BAS has not yet been explored empirically.

1.1. Evolutionary explanations of individual differences

Within evolutionary psychology, individual differences in personality and/or temperament are interpreted as variations in adaptive mechanisms that evolved to provide solutions to problems concerning reproduction and survival (Buss, 2008, 2009). Since environmental conditions were not equal for the entire human population, it may be assumed that some phenotypic variations were more adaptive in one environment than in another. Thus, there is no “gold standard” for a personality trait that could provide the best possible fitness in every environment (Penke, 2010; Penke, Denissen, & Miller, 2007). Therefore, it is reasonable to assume the existence of a variety of resource acquisition strategies which could ensure flexible and adaptive behaviour in different environmental conditions.

We can distinguish two main groups of resource acquisition strategies developed in social species: competition (e.g., stealing, trickery, aggression) and cooperation (e.g., social exchange, altruism) (Buss, 1999). Competitive strategies are mostly related to questions of social hierarchy, status, or power, with individuals ranking higher on the social scale having access to more resources whilst facing lower risks and required effort. In contrast, cooperative strategies are seen as mutually beneficial (Scott-Phillips, Dickins, & West, 2011). On a proximal level, cooperation can be manifested as volunteering, social exchange, reciprocal altruism, and so on (Buss, 1999; Tooby & Cosmides, 1988). We can assume that cooperative behaviour is driven by the need for social approval, which is a very powerful incentive (e.g., Izuma, Saito, & Sadato, 2010), and it serves the function of attaining social status. In economics, this is known as the ‘public good’ benefit. As such, helping others may be seen as an investment or even buying insurance for future events in which one would seek help from the same individuals. Which of these two strategies would be used, depends upon environmental conditions and individual differences.

The aim of this study is to examine empirically, for the first time, which of these two evolved resource acquisition strategies are related to individual differences in the BAS. We

expect the BAS to correlate with variation in both cooperative and competitive strategies, as reflected in different motives that are expected to fuel the exertion of these strategies.

The heterogeneity of the BAS may derive from the ‘arms race’ between predator and prey. The ‘Life-Dinner Principle’ (Dawkins & Krebs, 1979) suggests that the evolutionary selective pressure on the prey is much stronger than on the predator: if a predator fails to kill its prey, it has lost its dinner, but if the prey fails to avoid/escape being the predator's dinner, then it has lost its life. Although defensive behaviours, principally freezing, fleeing and defensive attack, are themselves relatively complex (Eilam, 2005), it is nonetheless true that the behaviour of the prey is intrinsically simpler than that of the predator: all it has to do is avoid/escape, making it, quite literally, life-or-death behaviour (Corr, 2008). In contrast, the predator has to develop counter-strategies to meet its BAS aims, which entail a higher degree of cognitive and behavioural sophistication over the prey's defensive behavioural repertoire. Another reason for the complexity of the BAS comes from heterogeneity of appetitive goals (e.g., securing food and finding/keeping a sexual mate), which demand a corresponding heterogeneity of BAS-related strategies.

The putative multidimensional nature of the BAS is also grounded in the neurobiology of personality, which recognizes two approach related traits: impulsivity and extraversion, that are related to different neurotransmitters. Impulsivity is associated with dopamine, serotonin (Dalley & Roiser, 2012), and testosterone (Montoya, Terburg, Bos, & van Honk, 2012). Testosterone has been found important in attaining social status in number of cross-species studies (e.g., Beaver & Amoss, 1982; Coe, Mendoza, & Levine, 1979; Elofsson, Mayer, Damsgård, & Winberg, 2000). In human studies, testosterone is linked with domination (Sellers, Mehl, & Josephs, 2007), choice of risky carriers (Sapienza, Zingales, & Maestripieri, 2009), aggression (Archer, 2006), and level of reproductive effort (Alvergne, Jokela, Faurie, & Lummaa, 2010), which all correspond to competitive motives. Thus, we may expect that the RST scales reflecting impulsivity (the SR and RST-Impulsivity) should correlate with competitive motives.

Neurobiologically, nurturance/cooperativeness is based on oxytocin system functions (e.g., Feldman, 2012; Yamasue et al., 2008). The second candidate for the neurobiological underpinnings of nurturance/cooperation are endogenous opiates, which are involved in the positive emotions that follow attainment or consumption of reward. This is a key feature of Reward reactivity, and is important in social affiliation, making opiates likely candidates for a biological substrate of Extraversion and Social Closeness (Berridge, 2012; Depue & Morrone-Strupinsky, 2005). Thus, we may expect that the RST-PQ scales designed closely to

extraversion (Reward Interest, Goal-Drive Persistence, and Reward reactivity) should correlate more with the cooperative motives.

2. Materials and methods

2.1. Participants and procedure

A total of 394 (208 male and 186 female) participants ($M_{AGE} = 27.99$; $SD = 9.70$, range from 16 to 54) completed three questionnaires online using LimeSurvey web application. Only complete data were recorded. The Ethics Committee of Faculty of Humanities and Social Sciences in Rijeka gave approval for the study.

2.2. Measures

We administered two RST questionnaires: Reinforcement Sensitivity Theory Personality Questionnaire (RST-PQ; Corr & Cooper, 2016), and the Sensitivity to Punishment and Sensitivity to Reward Questionnaire-20 (SPSRQ-20; Aluja & Blanch, 2011; Torrubia, Avila, Molto, & Caseras, 2001). We also administered the Assessment of Individual Motives (AIM-Q; Bernard, 2013) which provides a measure for cooperative and competitive resource acquisition strategies and integrity motives.

The RST-PQ (Corr & Cooper, 2016) contains 65 items for measuring the BAS, the Behavioural Inhibition System (BIS) and Fight/Flight/Freeze System (FFFS). The BAS consists of four subscales. People that score high on Reward Interest scale (seven items) are more likely to engage in anticipatory approach, exploration of new objects, places and people (e.g., “I regularly try new activities just to see if I enjoy them”). Goal-Drive-Persistence (seven items) measures the persistence in achieving the ultimate aim of obtaining a reward (e.g., “I put in a big effort to accomplish important goals in my life”). Reward reactivity (ten items) relates to the level of experiencing emotional reaction to reward (i.e., ‘pleasure’) and provides the positive reinforcement for BAS behaviour (e.g., “Good news makes me feel over-joyed”). Finally, Impulsivity (eight items) refers to the final stage of catching the biological reinforcer, where non-planning and fast reactions are more appropriate (e.g., “I think I should ‘stop and think’ more instead of jumping into things too quickly”). Using the criterion of Hu and Bentler (1999),

the four-factor model of the BAS in this study showed adequate goodness of fit indices ($\chi^2/df = 2.71$, CFI = .903; RMSEA = .066). Internal reliability coefficients (Cronbach's alpha) are 0.75 for Reward Interest, 0.83 for Goal-Drive Persistence, 0.75 for Reward reactivity, and 0.67 for Impulsivity.

The SPSRQ-20 (Aluja & Blanch, 2011; Torrubia et al., 2001) measures Sensitivity to Reward (SR; e.g., “Do you like being the centre of attention at a party or a social meeting”) and Sensitivity to Punishment (SP; e.g., “Are you often afraid of new or unexpected situations?”); each scale containing 10 items. Reliability coefficients are 0.66 for SR and 0.82 for SP.

The Croatian translation of both questionnaires was validated earlier (Krupić, Križanić, Ručević, Gračanin, & Corr, 2016). Data for the defensive BIS, FFFS, Defensive fight (for the RST-PQ) and the SP (for the SPSRQ) were also collected, but as they are out of scope of this study they were not analysed.

AIM-Q (Bernard, 2013) is a 60-item questionnaire that measures 15 human-specific motives (Bernard, 2009, 2010) within the evolutionary theory of human motivation (Bernard, Mills, Swenson, & Walsh, 2005). Each motive is represented by four items answered on a seven point Likert-type scale. Bernard (2013) distinguishes three types of motives: (a) motives facilitating individual integrity (Environmental Inquisitiveness, Threat Avoidance, Illness Avoidance); (b) motives facilitating competition for resources and mates (Interpersonal Inquisitiveness, Aggression, Appearance, Mental, Physical, Wealth, Sex); and (c) motives facilitating cooperation in order to gain resources (Commitment, Kin Altruism, Social exchange, Legacy and Meaning). Full description of the questionnaire and constructs can be found in Bernard and Lac (2014). Reliability coefficients are presented in Table 1. Generally, all except Illness avoidance achieve reliability above .70.

2.3. Analytic plan

Relationships between the BAS scales and AIM-Q motives were analysed by set correlation analysis (SCA), which provides the statistical control for a set of research factors (in our case gender and age), when relating one set of variables (in our case the BAS scales) to another (in our case 15 AIM-Q motives). In this way, confounding variables are held under control, and the likelihood of Type I error is reduced, which promotes the uniqueness of relationship between variables (Cohen, Cohen, Aiken, & West, 2003). Statistical control of gender and age is important in determining the unique adaptive account of the BAS, since they represent an important source of variation within the evolutionary psychology. Additionally,

we used Bonferroni correction in determining the statistical significance in order to reduce further Type I error due to a larger number of correlations tested.

3. Results

Descriptive statistics for AIM-Q and results of SCA are shown in Table 1, while zero order correlation matrices between and within questionnaires are available in Supplementary materials. All analyses were conducted using R version 3.2.2 (R Development Core Team, 2013), using package psych version 1.5.8 (Revelle, 2015).

Using set correlation, all canonical variates in the data set were taken into account in one index to provide an overall estimate of association. The overall relationship between personality traits and motives using Cohen's Set Correlation was $R^2 = .82$, which was statistically significant $F(6.75, 105) = 2294.39$, $p < 0.01$. Weak to moderate relationships ($R^2 = .05-.32$) were found between discrete motives and personality traits. Further, different patterns of partial correlations for AIM-Q motives, controlled for gender and age, were shown among BAS scales. In general, the SR and Impulsivity were more related with competitive, while Reward Interest, Goal-Drive Persistence and Reward reactivity were more related with cooperative motives, as expected. Reward interest was related with Kin Altruism, Meaning, Legacy, but also with Physical and Environmental Inquisitiveness, that belongs to competitive and integrity motives, respectively. Goal-Drive Persistence was related with Social exchange, while Reward reactivity showed links with Commitment from cooperative group of motives, and Threat avoidance from Integrity motives.

Table 1. Descriptive statistics and results of set correlations analysis between AIM-Q motives and approach dimensions of SPSRQ-20 and RST-PQ controlled for gender and age

	Motives facilitating individual integrity			Motives facilitating cooperation				
	THA	ILA	EIQ	COM	KIN	SOC	LEG	MEA
Gender	.01	-.03	.24**	.09	-.07	.05	.12	.11
Age	.06	.05	.01	-.04	-.09	.06	.05	.05
Reward Interest	-.08	-.11	.44**	-.02	.22**	.15	.32**	.32**
Goal-Drive Persistence	.07	.02	.07	.02	-.04	.23**	-.03	-.08
Reward reactivity	.26**	.14	-.00	.18**	.02	.14	.04	-.06
Impulsivity	-.04	.02	.07	.08	.12	-.07	.06	.03
Sensitivity to reward	-.19**	.17**	-.11	-.13	-.10	-.23**	-.09	-.00
M	15.49	12.29	17.96	18.11	16.03	20.25	12.36	11.98
SD	4.217	3.738	4.025	4.987	4.033	2.621	4.966	5.822
α	.73	.58	.87	.91	.75	.72	.87	.93
R	.29	.23	.56	.26	.28	.44	.38	.29
R ²	.086	.053	.318	.067	.079	.197	.143	.084
F (7, 386)	5.20**	3.09**	25.71**	3.98**	4.74**	13.51**	9.19**	5.05**

* $p < 0.05$; ** $p < 0.01$; α – Cronbach alpha; R – multiple correlation coefficient; R² – multiple determination coefficient; THA – Threat Avoidance; ILA – Illness Avoidance; EIQ - Environmental Inquisitiveness; COM – Commitment; KIN – Kin Altruism; SOC – Social; Exchange; LEG – Legacy; MEA – Meaning; positive correlation for Gender indicates higher score for males.

Table 1. (continued) Descriptive statistics and results of set correlations analysis between AIM-Q motives and approach dimensions of SPSRQ-20 and RST-PQ controlled for gender and age

	Motives facilitating competition for resources and mates						
	AGG	INI	SEX	APP	WEA	MEN	PHY
Gender	-.01	-.08	-.27**	.18**	-.11	.02	-.17**
Age	-.07	-.11	.06	.04	-.00	-.07	.02
Reward Interest	-.01	-.07	.00	.04	-.10	-.01	.25**
Goal Drive Persistence	-.05	-.08	-.14	-.03	.01	.10	.06
Reward reactivity	-.11	.03	-.02	-.04	.05	.01	-.04
Impulsivity	.21**	.22**	.17**	.06	.12	.01	-.11
Sensitivity to reward	.32**	.24**	.19**	.37**	.41**	.49**	.36**
M	6.84	10.53	8.60	6.64	6.75	10.63	10.97
SD	3.357	5.161	4.218	3.446	3.554	4.552	5.257
α	.80	.91	.85	.80	.84	.83	.89
R	.43	.42	.43	.38	.49	.53	.51
R ²	.183	.176	.186	.148	.239	.283	.262
F (7, 386)	12.37**	11.74**	12.60**	9.57**	17.29**	21.75**	19.58**

** $p < 0.01$; α – Cronbach alpha; R – multiple correlation coefficient; R² – multiple determination coefficient; AGG – Aggression; INI - Interpersonal Inquisitiveness; SEX – Sex; APP – Appearance; WEA – Wealth; MN – Mental; PH – Physical; positive correlation for Gender indicates higher score for males.

4. Discussion

In order to provide an evolutionary account of the BAS, we examined the relationships between interindividual variation on different BAS scales and different types of motives, including (a) motives facilitating individual integrity, (b) motives facilitating competition for resources and mates, and (c) motives facilitating cooperation. Overall, the BAS scales correlated with both resource acquisition strategies and, additionally, with the integrity motives. More specifically, discrete motives are found to correlate with different aspects of the BAS functioning. This suggests that different aspects of the BAS were shaped throughout evolutionary history in order to confront specific adaptive problems. Put simply, while the AIM-Q detects what were the adaptive goals, the BAS explains how these goals were obtained.

Weak to moderate relationships were found between discrete motives and personality traits, which is reasonable since motives and personality traits are not equivalent constructs. Motives are defined as a predisposition to behave in a directed fashion, focusing on behaviour solely, while personality traits are defined as complex constructs combining stable behavioural, cognitive and emotional characteristics (for details see Bernard & Lac, 2014). Thus, low to moderate correlations between the BAS scales and motives are expected.

Reward Interest correlated with the tendency of exploring the environment (Environmental inquisitiveness), participating in competitions that signal gender-appropriate physical ascendancy (Physical), caring for relatives (Kin Altruism), and with reciprocation among non-kin (Legacy and Meaning). In general, individuals that score high on Reward Interest scale show a tendency to act prosocially, or to contribute to society.

The next finding relates Goal-Drive Persistence with tendency to enter into reciprocal, mutually beneficial exchanges of resources with non-kin (Social Exchange). The cooperation is more of a long-term strategy (Barclay, 2013; Stevens, Cushman, & Hauser, 2005). It takes time to build trust between people, and even then, it is not certain whether it will be mutually beneficial. Therefore, it is not surprising that many studies show that reward delay capacity is important in maintaining cooperative behaviour (Brosnan, Salwiczek, & Bshary, 2010; Kortenkamp & Moore, 2006; Rosati, Stevens, Hare, & Hauser, 2007), which is the core feature of Goal-Drive Persistence.

Individuals high on Reward reactivity scales show tendency toward maintaining one's safety (Threat Avoidance) and a greater capacity for developing tender, intimate, supportive attachments with mates and off-spring (Commitment). Reward reactivity relates to emotional

reactions to the final attainment of a desired goal. It serves as “emotional fuel” for the previous BAS processes (Corr & Cooper, 2016). Positive outcome followed by positive emotional reaction serves as reinforcement of invested effort in attaining a desired goal. According to our results, these processes have the importance in maintaining safety and a relationship with others.

Compared to cooperation, competition as a resource acquisition strategy is a more short-term strategy (Barclay, 2013; Stevens et al., 2005). RST-PQ Impulsivity relates with motives such as achieving domination (Aggression), tendency of mocking others, being sarcastic (Interpersonal Inquisitiveness), and searching for mates (Sex). In addition, individuals high on SR are more willing to display intellectual and physical superiority (Mental and Physical, respectively), material resources (Wealth), and to invest resources in order to look well (Appearance). In general, a common feature of individuals that score high on RST-PQ Impulsivity and the SR is a tendency to represent themselves as better than others. However, it is important to emphasize the difference between SR and Impulsivity (RST-PQ), which appeared in our results. While Impulsivity relates exclusively to competitive motives, SR additionally correlates with integrity motives (Illness avoidance and Threat avoidance) and negatively with Social Exchange. Furthermore, the Impulsivity scale contains items that reflect tendencies of acting fast without thinking and not planning, thus reflecting poor executive function (e.g., “I think I should ‘stop and think’ more instead of jumping into things too quickly”). On the other hand, the SR contains items relating to behavioural tendencies (e.g., “When you are in a group, do you try to make your opinions the most intelligent or the funniest?”). The AIM-Q items are also designed to measure motivational tendencies on a behavioural level (e.g., “I show off my understanding of abstract or complex ideas so people will respect me”), which could result in common method variance with the SR, and thus spuriously increases correlation coefficients. Hence, we cannot discuss the relative importance of these two scales in competitiveness within this study, since they obviously measure different aspects of impulsivity.

The rest of associations were not significant, although zero-order correlation matrix in Supplementary materials might suggest the opposite. This discrepancy suggests that the BAS scales correlate with some other motives as well, but these relations are confounded, since both — the BAS scales and the motives — are highly inter-correlated. Thus, the discrepancy of the results represents the ability of SCA to detect confounding effects between two sets of variables. This way, the SCA provides a unique relationship between two variables, when many other variables are held under statistical control, and these effects are very likely to replicate.

Most of the empirical work in the original version of the RST was based on animal studies, particularly rodents. Upon these experiments, the idea of the unidimensional BAS could seem very plausible. However, as we can see, different adaptive goals demand different strategies of the BAS. We believe that the BAS complexity arises from highly complex human environment in comparison to rodents'— which has not been taken into account in the original version of RST.

The findings of this study hold significance in understanding the differences that are commonly observed between the various BAS scales (e.g. Jackson & Smillie, 2004; Krupić & Corr, 2014; Smillie, Jackson, & Dalgleish, 2006). Understanding the conceptual differences between the BAS scales could lead toward setting more precise hypotheses in RST studies. However, much work is needed in order to produce a complete picture of the evolutionary origins of the BAS. Further studies should focus on sex dimorphism and relationships between different aspects of the BAS functioning and variables such as relationship instability, sociosexuality, and parental effort, which are important for understanding its adaptive functions.

The major limitation of this study concerns the usage of only one psychometric measure for competitive and cooperative motives, and the study design that does not allow for causal interpretation. Furthermore, we did not include the BIS and FFFS scales in our study, what might have influenced the results. Currently, the theory is not clear whether the approach and avoidance system function separately, or they have mutually inhibitory effects, which is beyond the scope of this paper (however, reanalysed data can be found in Supplementary materials).

In conclusion, the results of this study show that impulsivity, as measured by RST-PQ and SR from SPSRQ, relates to competitive, Goal-Drive Persistence and Reward reactivity relate to cooperative, while Reward Interest relates to both resource acquisition strategies, which altogether represent a set of novel findings in RST research. Clearly, the evolutionary perspective provides a coherent theoretical account of the multidimensionality of approach motivation.

References

- Aluja, A., & Blanch, A. (2011). Neuropsychological Behavioral Inhibition System (BIS) and behavioral approach system (BAS) assessment: A shortened Sensitivity to Punishment and Sensitivity to Reward Questionnaire version (SPSRQ-20). *Journal of Personality Assessment, 93*(6), 628–636. <http://dx.doi.org/10.1080/00223891.2011.608760>.
- Alvergne, A., Jokela, M., Faurie, C., & Lummaa, V. (2010). Personality and testosterone in men from a high-fertility population. *Personality and Individual Differences, 49*, 840–844. <http://dx.doi.org/10.1016/j.paid.2010.07.006>.
- Archer, J. (2006). Testosterone and human aggression: An evaluation of the challenge hypothesis. *Neuroscience and Biobehavioral Reviews, 30*, 319–345. <http://dx.doi.org/10.1016/j.neubiorev.2004.12.007>.
- Barclay, P. (2013). Strategies for cooperation in biological markets, especially for humans. *Evolution and Human Behavior, 34*, 164–175. <http://dx.doi.org/10.1016/j.evolhumbehav.2013.02.002>.
- Beaver, B., & Amoss jr, M. (1982). Aggressive behavior associated with naturally elevated serum testosterone in mares. *Applied Animal Ethology, 8*, 425–428. [http://dx.doi.org/10.1016/0304-3762\(82\)90055-4](http://dx.doi.org/10.1016/0304-3762(82)90055-4).
- Bernard, L. C. (2009). Consensual and behavioral validity of a measure of adaptive individual differences dimensions in human motivation. *Motivation and Emotion, 33*, 303–319. <http://dx.doi.org/10.1007/s11031-009-9131-7>.
- Bernard, L. C. (2010). Motivation and personality: Relationships between putative motive dimensions and the five factor model of personality. *Psychological Reports, 106*, 613–631. <http://dx.doi.org/10.2466/PR0.106.2.613-631>.
- Bernard, L. C. (2013). *Manual for the Assessment of Individual Motives–Questionnaire*. Unpublished manuscript, Loyola Marymount University, Los Angeles, CA.
- Bernard, L. C., & Lac, A. (2014). The incremental validity of motive traits of action: Predicting behavior longitudinally. *Individual Differences Research, 12*, 79–100.
- Bernard, L. C., Mills, M., Swenson, L., & Walsh, R. P. (2005). An evolutionary theory of human motivation. *Genetic, Social, and General Psychology Monographs, 131*, 129–184. <http://dx.doi.org/10.3200/MONO.131.2.129-184>.
- Berridge, K. C. (2004). Motivation concepts in behavioral neuroscience. *Physiology and Behavior, 81*, 179–209. <http://dx.doi.org/10.1016/j.physbeh.2004.02.004>.

- Berridge, K. C. (2012). From prediction error to incentive salience: Mesolimbic computation of reward motivation. *European Journal of Neuroscience*, *35*, 1124–1143. <http://dx.doi.org/10.1111/j.1460-9568.2012.07990.x>.
- Berridge, K. C., & Robinson, T. E. (2003). Parsing reward. *Trends in Neurosciences*, *26*, 507–513. [http://dx.doi.org/10.1016/S0166-2236\(03\)00233-9](http://dx.doi.org/10.1016/S0166-2236(03)00233-9).
- Brosnan, S. F., Salwiczek, L., & Bshary, R. (2010). The interplay of cognition and cooperation. *Philosophical Transactions of the Royal Society, B: Biological Sciences*, *365*(1553), 2699–2710. <http://dx.doi.org/10.1098/rstb.2010.0154>.
- Buss, D. M. (1999). *Evolutionary psychology*. London: Allyn and Bacon.
- Buss, D. M. (2008). Human nature and individual differences: Evolution of human personality. In O. P. John, R. W. Robins, & L. A. Pervin (Eds.), *Handbook of personality theory and research* (pp. 29–60) (3rd ed.). New York: Guilford Press.
- Buss, D. M. (2009). How can evolutionary psychology successfully explain *Personality and Individual Differences?* *Perspectives on Psychological Science*, *4*, 359–366. <http://dx.doi.org/10.1111/j.1745-6924.2009.01138.x>.
- Coe, C. L., Mendoza, S. P., & Levine, S. (1979). Social status constrains the stress response in the squirrel monkey. *Physiology and Behavior*, *23*, 633–638. [http://dx.doi.org/10.1016/0031-9384\(79\)90151-3](http://dx.doi.org/10.1016/0031-9384(79)90151-3).
- Cohen, J., Cohen, P., Aiken, L. S., & West, S. G. (2003). *Applied multiple regression/correlation analysis for the behavioural sciences* (3rd ed.). London: Erlbaum.
- Corr, P. J. (2008). Reinforcement sensitivity theory (RST): Introduction. In P. J. Corr (Ed.), *The reinforcement sensitivity theory and personality* (pp. 1 - 43). Cambridge: Cambridge University Press.
- Corr, P. J., & Cooper, A. (2016). The Corr-Cooper Reinforcement Sensitivity Theory Personality Questionnaire (RST-PQ): Development and validation. *Psychological Assessment*. <http://dx.doi.org/10.1037/pas0000273> (in press).
- Dalley, J. W., & Roiser, J. P. (2012). Dopamine, serotonin and impulsivity. *Neuroscience*, *215*, 42–58. <http://dx.doi.org/10.1016/j.neuroscience.2012.03.065>.
- Dawkins, R., & Krebs, J. R. (1979). Arms races between and within species. Proceedings of the Royal Society of London. *Series B, Containing Papers of a Biological Character. Royal Society (Great Britain)*, *205*(1161), 489–511. <http://dx.doi.org/10.1098/rspb.1979.0081>.
- Depue, R. A., & Morrone-Strupinsky, J. V. (2005). A neurobehavioral model of affiliative bonding: implications for conceptualizing a human trait of affiliation. *Behavioral and*

- Brain Sciences*, 28, 313–350. <http://dx.doi.org/10.1017/S0140525X05000063>
(discussion 350–395).
- Eilam, D. (2005). Die hard: A blend of freezing and fleeing as a dynamic defense — Implications for the control of defensive behavior. *Neuroscience and Biobehavioral Reviews*, 29, 1181–1191. <http://dx.doi.org/10.1016/j.neubiorev.2005.03.027>.
- Elofsson, U. O., Mayer, I., Damsgård, B., & Winberg, S. (2000). Intermale competition in sexually mature arctic charr: Effects on brain monoamines, endocrine stress responses, sex hormone levels, and behavior. *General and Comparative Endocrinology*, 118, 450–460. <http://dx.doi.org/10.1006/gcen.2000.7487>.
- Feldman, R. (2012). Oxytocin and social affiliation in humans. *Hormones and Behavior*, 61, 380–391. <http://dx.doi.org/10.1016/j.yhbeh.2012.01.008>.
- Gray, J. A., & McNaughton, N. (2000). *The neuropsychology of anxiety: An enquiry into the functions of the septo-hippocampal system*. New York: Oxford University Press.
- Hu, L. T., & Bentler, P. M. (1999). Cutoff criteria for fit indexes in covariance structure analysis: Conventional criteria versus new alternatives. *Structural Equation Modeling: A Multidisciplinary Journal*, 6, 1–55. <http://dx.doi.org/10.1080/10705519909540118>.
- Izuma, K., Saito, D. N., & Sadato, N. (2010). Processing of the incentive for social approval in the ventral striatum during charitable donation. *Journal of Cognitive Neuroscience*, 22, 621–631. <http://dx.doi.org/10.1162/jocn.2009.21228>.
- Jackson, C. J., & Smillie, L. D. (2004). Appetitive motivation predicts the majority of personality and an ability measure: A comparison of BAS measures and a re-evaluation of the importance of RST. *Personality and Individual Differences*, 36, 1627–1636. <http://dx.doi.org/10.1016/j.paid.2003.06.010>.
- Kenrick, D. T., & Shiota, M. N. (2008). Approach and avoidance. In A. J. Elliot (Ed.), *Handbook of approach and avoidance motivation* (pp. 273–288). New York: Psychology Press.
- Kortenkamp, K. V., & Moore, C. F. (2006). Time, uncertainty, and individual differences in decisions to cooperate in resource dilemmas. *Personality and Social Psychology Bulletin*, 32, 603–615. <http://dx.doi.org/10.1177/0146167205284006>.
- Krupić, D., & Corr, P. J. (2014). Individual differences in emotion elicitation in university examinations: A quasi-experimental study. *Personality and Individual Differences*, 71, 176–180. <http://dx.doi.org/10.1016/j.paid.2014.08.001>.

- Krupić, D., Križanić, V., Ručević, S., Gračanin, A., & Corr, P. J. (2016). Five reinforcement sensitivity theory (RST) of personality questionnaires: Comparison, validity and generalization. (*in submission*).
- Montoya, E. R., Terburg, D., Bos, P. A., & van Honk, J. (2012). Testosterone, cortisol, and serotonin as key regulators of social aggression: A review and theoretical perspective. *Motivation and Emotion, 36*, 65–73. <http://dx.doi.org/10.1007/s11031-011-9264-3>.
- Penke, L. (2010). Bridging the gap between modern evolutionary psychology and the study of individual differences. In D. M. Buss, & P. H. Hawley (Eds.), *The evolution of Personality and Individual Differences* (pp. 243–279). New York: Oxford University Press. <http://dx.doi.org/10.1093/acprof:oso/9780195372090.003.0009>.
- Penke, L., Denissen, J. J. A., & Miller, G. F. (2007). The evolutionary genetics of personality. *European Journal of Personality, 21*, 549–587. <http://dx.doi.org/10.1002/per.629>.
- R Development Core Team (2013). *R: A language and environment for statistical computing*. R Foundation for Statistical Computing, Vienna, Austria. Vienna, Austria: R Foundation for Statistical Computing (URL <http://www.R-project.org/>).
- Revelle, W. (2015). *Psych: Procedures for Personality and Psychological Research*. Evanston, Illinois, USA: Northwestern University (<http://CRAN.R-project.org/package=psych>).
- Rosati, A. G., Stevens, J. R., Hare, B., & Hauser, M. D. (2007). The evolutionary origins of human patience: Temporal preferences in chimpanzees, bonobos, and human adults. *Current Biology, 17*, 1663–1668. <http://dx.doi.org/10.1016/j.cub.2007.08.033>.
- Sapienza, P., Zingales, L., & Maestripieri, D. (2009). Gender differences in financial risk aversion and career choices are affected by testosterone. *Proceedings of the National Academy of Sciences of the United States of America, 106*, 15268–15273. <http://dx.doi.org/10.1073/pnas.0907352106>.
- Scott-Phillips, T. C., Dickins, T. E., & West, S. A. (2011). Evolutionary theory and the ultimate–proximate distinction in the human behavioral sciences. *Perspectives on Psychological Science, 6*, 38–47. <http://dx.doi.org/10.1177/1745691610393528>.
- Sellers, J. G., Mehl, M. R., & Josephs, R. A. (2007). Hormones and personality: Testosterone as a marker of individual differences. *Journal of Research in Personality, 41*, 126–138. <http://dx.doi.org/10.1016/j.jrp.2006.02.004>.
- Smillie, L. D., Jackson, C. J., & Dalgleish, L. I. (2006). Conceptual distinctions among Carver and White's (1994) BAS scales: A reward-reactivity versus trait impulsivity perspective.

Personality and Individual Differences, 40, 1039–1050. <http://dx.doi.org/10.1016/j.paid.2005.10.012>.

Stevens, J. R., Cushman, F. A., & Hauser, M. D. (2005). Evolving the psychological mechanisms for cooperation. *Annual Review of Ecology, Evolution, and Systematics*, 36, 499–518. <http://dx.doi.org/10.1146/annurev.ecolsys.36.113004.083814>.

Tooby, J., & Cosmides, L. (1988). The evolution of war and its cognitive foundations. Institute for evolutionary studies technical report, 88(1). (pp. 1–15). Santa Barbara: Institute for Evolutionary Studies, University of California at Santa Barbara (Retrieved from <http://www.cep.ucsb.edu/papers/EvolutionofWar.pdf>).

Torrubia, R., Avila, C., Molto, J., & Caseras, X. (2001). The Sensitivity to Punishment and Sensitivity to Reward Questionnaire (SPSRQ) as a measure of Gray's anxiety and impulsivity dimensions. *Personality and Individual Differences*, 31(6), 837–862. doi:10.1016/S0191-8869(00)00183-5.

Yamasue, H., Abe, O., Suga, M., Yamada, H., Rogers, M. A., Aoki, S., ... Kasai, K. (2008). Sex-linked neuroanatomical basis of human altruistic cooperativeness. *Cerebral Cortex*, 18(10), 2331–2340. doi:10.1093/cercor/bhm254

7.6.

Slow and fast BAS: Interpretation of the behavioural approach system (BAS) within Life History Theory.

Krupić, D., Banai, B., Corr, P. J. (2017).

Journal of Individual Differences. Submitted.

7.6. Slow and fast BAS: Interpretation of the behavioural approach system (BAS) within Life History Theory

Abstract

The behavioural approach system (BAS) has been shown to be important in everyday life. However, its putative evolutionary origin has not been extensively studied. The purpose of this study is to explore the relationship between the BAS processes and life history strategies or lifestyles within life history theory. The BAS scales were assessed by RST-PQ and SPSRQ-20, while lifestyles with Mini-K. Data of four hundred and fifty-seven participants (173 male) were analysed by structural equation model to examine the relationship between the BAS scales and total score of the Mini-K, and set correlation analysis was conducted to establish relationship of the BAS with the Mini-K subscales. The structural model showed that Reward Interest, Goal-Drive Persistence and Reward reactivity from RST-PQ correlated with a slow lifestyle, while Impulsivity-RST-PQ and Sensitivity to Reward (SR) from SPSRQ-20 did not correlate with the Mini-K. However, set correlation analysis revealed that the SR correlate negatively only with the Mini-K subscale Experience in romantic relationship, and highlighted the importance of Insight, planning, and control in explaining the role of the BAS within slow lifestyle strategy. The findings are discussed in terms of possible evolutionary origin of the BAS and its components.

Keywords: Reinforcement sensitivity theory; evolution; life history theory; behavioural approach system

1. Introduction

Motivation psychology is concerned with two main questions: the *what* and the *how* of the direction and strength of behaviour (Kruglanski, Chernikova, & Kopetz, 2015). The *what* represents the list of motives that people perceive as attractive, and the *how* focuses on the fundamental processes of attaining motives from the list. Also, there is another question that has been less studied: *Why*. Why certain motives are more important than others, and what are their functions? Moreover, are there specific processes that serve to attain specific motives? Answers to those questions lie in the field of evolutionary psychology.

People have different needs and desires, that is, they differ in *what* they want and *how* strongly they want it (Baumeister, 2016). In general, individual differences are interpreted by evolutionary psychology as variations in adaptive mechanisms that evolved to provide solutions for problems concerning reproduction and survival (Buss, 2008). It is assumed that organisms are equipped with genetically encoded strategies that manifest differently in various environmental conditions. This flexibility ensures maximization of expected fitness (Hagen & Hammerstein, 2005). In this study, we explore the evolutionary origin of resource acquisition strategies that enable adjustment to environmental conditions and, therefore, enhance the chance of gaining resources relevant for survival and reproductive success. In this paper, we try to link the *how* with *what* aspect of motivation, and to provide the *why* of these links.

1.1 Approach motivation

Among others, appetitive or approach motivation is assumed to reflect the resource acquisition mechanism (Kenrick & Shiota, 2008). One of the most studied approach/avoidance motivation traits is the behavioural approach system (BAS) which is one of the systems within reinforcement sensitivity theory (RST; Corr 2008). This neuropsychological personality theory proposes the existence of three brain-behavioural circuits, which represent general emotional-motivational systems: BAS representing approach, and the behavioural inhibition system (BIS) and fight-flight-freezing system (FFFS) representing defensive systems (Corr, 2008; Gray & McNaughton, 2000). This study focuses only on a part of the theory concerning the BAS.

The BAS is defined as brain-behavioural system that mediates reaction to cues of reward and non-punishment, and its primary function is to move an organism up the temporo-spatial gradient (Gray & McNaughton, 2000). The BAS decomposes its primary function from a start state (e.g., the idea of, or the physical distance to a source of food) towards the final biological reinforcer (e.g., consumption of food) into four intertwined process: (a) identification of the biological important resource; (b) planning on how to attain the resource; (c) execution of the plan (consummation); and lastly, (d) activation of pleasure system following attainment of the resource that should maintain motivation for attaining the resource in the future (Corr, 2008, 2013; Corr, DeYoung, & McNaughton, 2013). Each of these stages play an important role in obtaining resources. In recent developments of RST instruments, these processes are operationalised as: Reward Interest, reflecting identification of the biological reinforcer; Goal-Drive Persistence, encompassing planning behaviour; Impulsivity, reflecting fast reaction at the final stage of execution of the plan; and Reward reactivity, representing emotional (and self-reinforcing) reactions on receiving the reward (Corr & Cooper, 2016). The main purpose of the study is to explore the importance of these functions in attaining certain types of goals.

Several authors have discussed the role of the BAS from evolutionary psychological perspective. For instance, MacDonald (1995; 2012) postulated the existence of two broad types of the BAS: Dominance/Sensation Seeking and Nurturance/Love. They present two qualitatively different aspects of the same system. The former is described as impulsive part of extraversion, concerned by establishing the social dominance, surgency and aggression, while the later presents mechanism of establishing supportive social network through maintaining good relationships in social environment. Later psychometric studies confirmed the existence of two conceptually similar subtypes of the BAS. Depue (2006) describes MacDonald's (1995) Dominance/Sensation Seeking and Nurturance/Love under labels “agency” and “affiliation”, respectively. Affiliation reflects enjoying and valuing close interpersonal bonds, while Agency reflects social dominance, enjoyment of leadership roles, assertiveness, and a subjective sense of potency in accomplishing goals. A similar perspective has been offered by DeYoung, Quilty, & Peterson, (2007) extracting two correlated subfactors within Extraversion: Assertiveness and Enthusiasm. Assertiveness encompasses traits related to drive, leadership, and dominance; and Enthusiasm encompasses both outgoing friendliness or sociability and the tendency to experience and express positive emotion.

In line with the above studies, a recent study (Krupić, Gračanin, & Corr, 2016) showed the different roles of the BAS subscales in predicting two kinds of resource acquisition

strategies, namely cooperation and competitiveness. Specifically, Goal-Drive Persistence and Reward reactivity were associated exclusively with cooperation; Impulsivity with competition; while Reward Interest has not been exclusively related to one particular strategy - the latter factor correlated with exploring the environment, participating in competitions that signal gender-appropriate physical ascendancy, caring for relatives, and with reciprocation among non-kin. Goal-Drive Persistence was related to social exchange, while Reward reactivity with tendency of nurturing intimate relationships. These findings showed the importance of the BAS processes in the two broad evolutionary domains.

To sum up, growing body of evidences suggest that the BAS has two broad functions: one primarily concerned with resource acquisition and the second oriented toward social environment. In this study we examine how the BAS functions correlate with life history theory (LHT) continuum.

1.2. Life history theory (LHT)

The LHT represents an evolutionary-economic framework to study the optimal allocation of bioenergetic and material resources (Sherman, Figueredo, & Funder, 2013). An organism distributes available resources between somatic effort (growth, maintenance and development) and reproductive effort (Geary, 2002). From the LHT perspective a fundamental trade-offs are made between current and future reproduction, between quality and quantity of offspring, and between mating and parenting effort (Del Giudice, 2014).

The LHT uses the fast-slow continuum for explaining differences between species (Del Giudice, Gangestad, & Kaplan, 2015). Species with “slow” life history strategy have late maturation and reproduction, characterized by slow growth, large body size, low fertility, long lifespan, and high investment in offspring, while “fast” species are characterized by early maturation and reproduction, fast growth, small body size, high fertility, short lifespan, and low investment in offspring quality (Figueredo et al., 2005). As a species, humans fall at the “slower” end of continuum (Kuzawa & Bragg, 2012).

The same continuum may be used to differentiate individuals within a species. The “fast” individuals are perceived as more exploitative/antisocial, bold, active, aggressive, less sociable, impulsive, prone to risk-taking, and dominant (Del Giudice, 2014; Sih & Del Giudice, 2012; Wolf, van Doorn, Leimar, & Weissing, 2007; Réale et al., 2010), while the individuals

at the "slow" end of continuum perceive themselves more agreeable, conscientious, and honest (Del Giudice et al., 2015).

There is a limited amount of energy or resources that an individual can absorb from the environment for his/her survival and reproduction during a lifetime. Generally, evolution favours individuals that most efficiently allocate limited resources in their distal genetic interests of reproduction and survival (Kaplan & Gangestad, 2005). It has been shown that psychological traits and behaviours related to slow life history strategy (such as maintaining close relationships with friends, parents and partners; or long-term planning and persistence in goal-achieving) load on modestly heritable general factor (Figueredo, Vásquez, Brumbach, & Schneider, 2004) However, expression of those traits, tend not to be genetically fixed. Environmental conditions (such as predation or diseases) highly influences adaptiveness of the two lifestyles (Quinlan, 2007; Ellis, Figueredo, Brumbach, & Schomler, 2009). For instance, in harsh environmental conditions it is more adaptive to start mating early and have low parental investment, to maximize reproductive success. These environmental factors in early childhood may shape the development of personality traits (see Simpson, Griskevicius, & Kim, 2011). For example, low parental investment, such as father absence, is related to adopting faster life history strategy in puberty (Belsky, Steinberg, & Draper, 1991; Ellis, 2004). Individuals that have grown under more uncertain environmental conditions tend to increase the quantity of offspring, by having earlier sexual intercourses and less stable romantic relationships. In contrast, slow lifestyle strategy may seem more adaptive in relatively predictable environments with low-risk mortality resulting in high parental effort, restricted sociosexuality, and prosocial/cooperative behaviours.

1.3 Present study

The aim of the present study is to establish the relationship between fast life history lifestyle and the BAS function oriented exclusively to resource acquisition, and slow lifestyle with the BAS function oriented toward maintaining social relations. Based on a previous study of Krupić, Gračanin, et al. (2016) we expect that Impulsivity should reflect "fast" lifestyle, while Reward reactivity and Goal-Drive Persistence should reflect "slow" lifestyle. In another words, we expect that "fast individuals" should score lower on Goal-Drive Persistence and Reward reactivity, and higher on Impulsivity, and vice versa for "slow individuals". In order to capture all aspects of the BAS functioning, the RST-PQ (Corr & Cooper, 2016) and SPSRQ-

20 (Aluja & Blanch, 2011) would be used. In our recent study (Krupić, Corr, Ručević, Križanić, & Gračanin, 2016) we compared five RST questionnaires. We extracted four types of the BAS scales. The only questionnaire that covers all four variants of the BAS scales is the RST-PQ. The SPSRQ in original version has shown many problems with construct validity, so Aluja and Blanch (2011) constructed a short version to improve its construct validity. Another reason for inclusion of the SPSRQ-20 is that the SR and RST-PQ show some dissimilarity. Namely, the SR focuses more on behavioural, while Impulsivity on cognitive aspect of impulsivity.

2. Methods

2.1. Participants and procedure

Four hundred and fifty-seven (173 male and 284 female) participants (MAGE = 31.51; SDAGE = 9.24) completed the three questionnaires online using Google Form web application. Ethical committee of Faculty of Humanities and Social Science in Osijek gave the approval for this study.

2.2. Measures

The RST-PQ (Corr & Cooper, 2016) contains four the BAS scales: seven-items Reward Interest (e.g., *“I regularly try new activities just to see if I enjoy them”*); seven-items Goal-Drive Persistence (e.g., *“I put in a big effort to accomplish important goals in my life”*); ten-items Reward reactivity (e.g., *“Good news makes me feel over-joyed”*), and; eight-items Impulsivity (e.g., *“I think I should ‘stop and think’ more instead of jumping into things too quickly”*). All items are answered on a four-point Likert scale. The Sensitivity to Reward (SR; e.g. *“Would you like to be a socially powerful person?”*) from Sensitivity to punishment Sensitivity to Reward Questionnaires - 20 (SPSRQ-20; Aluja & Blanch, 2011) contains ten dichotomous items with yes/no response format.

The Mini-K questionnaire is a 20-item single-scale measure of behavioural and cognitive aspects of life history strategies (Figueredo et al., 2006), based on more comprehensive Arizona Life History Battery (ALHB; Figueredo, 2007). Figueredo, de Baca

and Woodley (2013) recommend the use of this 20-item short-form when the principal focus of the research is not life history, per se, while the full 199-item Arizona Life History Battery should instead be used in studies primarily focused on life history strategy. CFA model displayed on the left side of the Figure 1 showed that the Mini-K scores can be used to represent the LHT on lower and general level. Details of the CFA results are provided in *Supplementary materials*. Participants responded on a 7-point Likert scale. Higher scores reflect slower lifestyle.

3. Results

Descriptive statistics, reliability coefficients and correlations between LHT and BAS variables are presented in Table 1. Cronbach alpha reliability coefficients for the Mini-K, Reward Interest, Goal-Drive Persistence and Reward reactivity were above .80, while for the SR and Impulsivity were .68 and .69, respectively. Relationships between Mini-K and the BAS scales are examined by structural model presented in Figure 1. The examined model achieved acceptable goodness of fit indices; $\chi^2(213) = 531.12$, $\chi^2/df=2.49$, CFI = .89, RMSEA = .073, SRMR = .068. The SR and Impulsivity did not correlate significantly, while the rest of the BAS scales from RST-PQ scales correlated positively with total score of the Mini-K. Thus, Reward Interest, Goal-Drive Persistence and Reward reactivity reflect slow lifestyle.

In line with Jonason, Koenig and Tost's (2010) suggestion that the general score of Mini-K should be interpreted with caution due to very broad nature of the construct, the CFA revealed that the Mini-K represents the hierarchically organized composite of adaptive strategies. This enabled the analysis on lower and general level. We conducted set correlation analysis (SCA) to examine the relationship of the BAS scales and Mini-K subscales. The SCA is specific form of regression analysis that is able to control intercorrelations among the predictors and among the set of intercorrelated criterion variables (Cohen, Cohen, West, & Aiken, 2003). The two sets of variables were highly correlated (Cohen's set correlation $R^2 = .59$). Insight, planning, and control and Friends social contact and support subscales contribute the most to correlation with Reward Interest, Goal-Drive Persistence and Reward reactivity. The SR show the most distinct pattern. It is negatively correlated with Experience in close relationships, decreases by ageing and it is higher in men. The results of the SCA among male and female participants did not differ (*full information provided in Supplementary materials*).

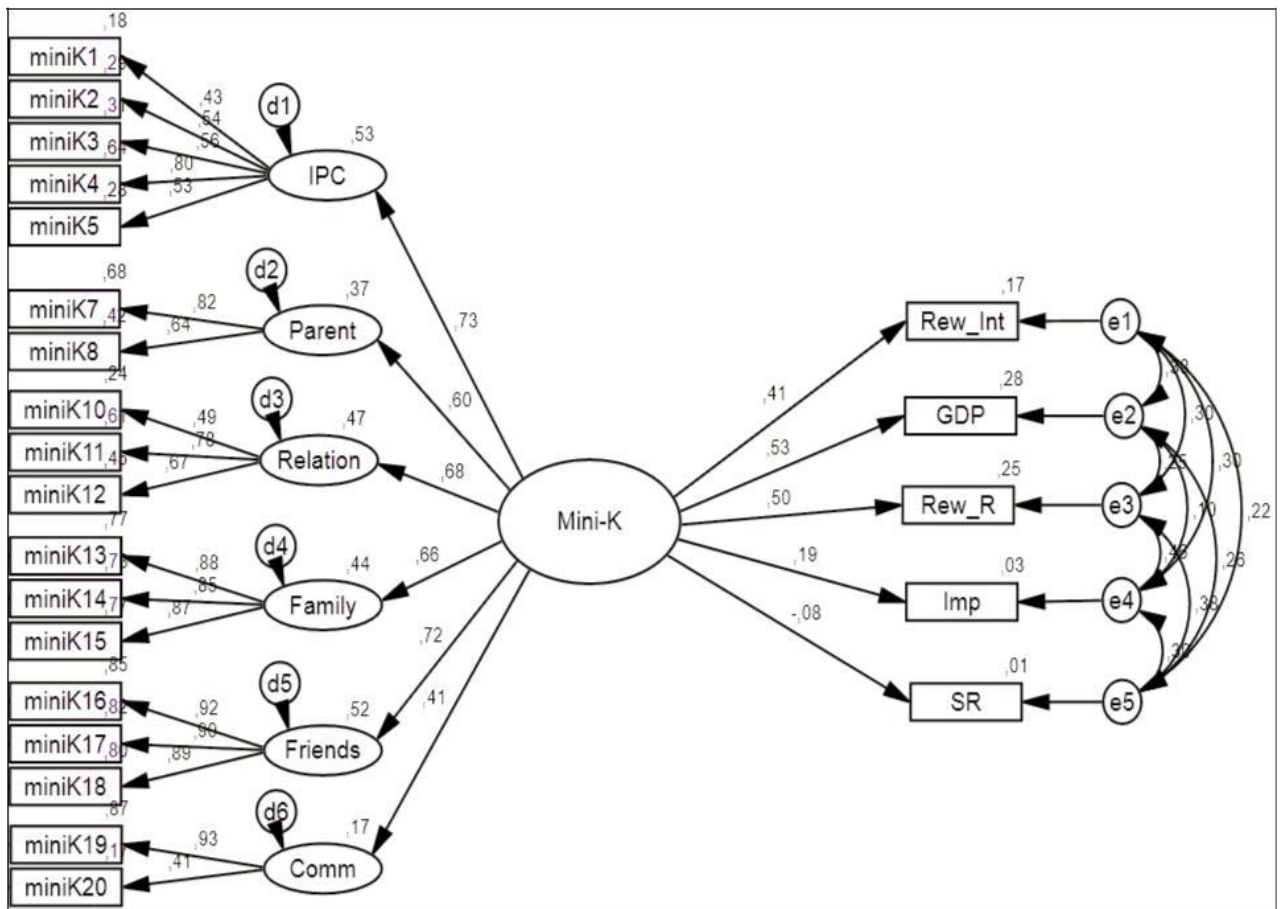

Figure 1. Relationship between general score of the Mini-K and the BAS scales
Note: *IPC* - Insight, planning, and control; *Parent* - Mother/father relationship quality; *Relation* - Experience in close relationships; *Family* - Family social contact and support; *Friends* - Friends social contact and support; *Comm* - Engagement in community; *RewInt*– Reward Interest; *GDP* – Goal-Drive Persistence; *Rew_R* – Reward reactivity; *Imp* – Impulsivity; *SR* – Sensitivity to Reward.

Table 1.

Descriptive statistics and correlational matrix of the BAS scales and the Mini-K

	M	SD	α	2.	3.	4.	5.	6.	7.	8.	9.	10.	11.	12.
1. Mini-K – total score	96.18	17.70	.85	.68**	.59**	.67**	.72**	.71**	.47**	.32**	.44**	.39**	.14**	-.13**
Insight, planning and														
2. control	25.65	5.49	.74	-	.24**	.36**	.28**	.42**	.18**	.44**	.57**	.38**	.13**	.04
Mother/father relationship														
3. quality	10.10	3.41	.69		-	.33**	.42**	.35**	.15**	.10*	.15**	.22**	.10*	-.04
Experience in close														
4. relationships	16.37	4.18	.60			-	.33**	.37**	.20**	.08	.27**	.24**	.06	-.18**
Family contacts and														
5. support	13.42	5.19	.89				-	.46**	.31**	.16**	.20**	.22**	.09	-.14**
Friends social contact and														
6. support	17.16	4.14	.92					-	.24**	.30**	.29**	.37**	.16**	-.09
Engagement in														
7. community	5.48	3.08	.56						-	.19**	.18**	.10*	.11*	.03
Reward Interest														
8. Reward Interest	19.88	4.21	.82							-	.55**	.47**	.34**	.22**
Goal-Drive Persistence														
9. Goal-Drive Persistence	20.42	4.28	.84								-	.49**	.21**	.21**
Reward reactivity														
10. Reward reactivity	28.65	5.34	.82									-	.50**	.35**
Impulsivity														
11. Impulsivity	20.03	4.16	.69										-	.26**
Sensitivity to Reward														
12. Sensitivity to Reward	4.37	2.36	.68											-

*- $p < 0.05$; **- $p < 0.01$

4. Discussion

The main aim of the study was to examine the relationship between the behavioural approach system (BAS) and life-history theory (LHT). Generally, Reward Interest, Goal-Drive Persistence and Reward reactivity were found to be related to the slow, while the SR related to the fast lifestyle. Set correlation analysis (SCA) with the BAS scales and lower level of Mini-K factors showed: (a) Insight, planning and control correlated with Reward Interest, Goal-Drive Persistence and Reward reactivity; (b) Friend social contact and support with Reward Interest and Reward reactivity; and (c) Experience in close relationship correlated negatively with the SR.

In the following discussion, the framework to interpret the BAS components within LHT will follow Penke, Denissen & Miller (2007) framework of levels to study personality throughout evolutionary theory. Here the both BAS scales and Mini-K scales reflect constructs that operate on the endophenotypic level, which assumes that the scores of the scales reflect psychological mechanisms that shape the personality traits on dispositional level.

Table 2.

Set correlation analysis showing partial correlations between the BAS scales and the Mini-K subscales

	Reward Interest	Goal-Drive Persistence	Reward Reactivity	Impulsivity	SR
<i>Gender</i>	-.03	.05	.04	-.05	-.16*
<i>Age</i>	.01	-.09	-.11	-.09	-.27**
Insight, planning, and control	.41**	.53**	.27**	.08	.15
Mother/father relationship quality	-.03	-.03	.05	.03	.00
Experience in close relationships	-.13	.05	.03	-.02	-.16*
Family social contact and support	-.01	.01	.01	-.01	-.11
Friends social contact and support	.17*	.02	.20**	.11	-.08
Engagement in community	.11	.08	.00	.08	.11
<i>R</i>	.49	.59	.47	.22	.39
<i>R2</i>	.24	.34	.22	.05	.15
<i>F(8,448)</i>	17.72**	29.34**	15.48**	2.78	9.90**

4.1. Insight, planning and control

Insight, planning and control highly correlated to Reward Interest, Goal-Drive Persistence and Reward reactivity. According to Figueredo, Cuthbertson, Kauffman, Weil and Gladden (2012), higher levels of executive functions are prerequisite in development of the slow lifestyle strategy, and vice versa for fast lifestyle (Wenner, Bianchi, Figueredo, Rushton, & Jacobs, 2013). They argue that the ability to inhibit impulse to consume immediate gratification (e.g. self-control) is crucial to strive towards more long-term goals. This is the core feature of Goal-Drive Persistence, while planning is one of the core features of Reward Interest, which represents incentive motivation or initiativeness. Hence, it is not surprising that these two BAS scales were the most predicted BAS scales.

Reward reactivity is also related with executive function reflecting slow lifestyle. This was not expected, since the Reward reactivity reflect mainly the emotional BAS component, e.g. the *liking* component of the BAS (Krupić, et al., 2017). To explain this relationship, we examined the correlations between Mini-K items and scores of the BAS scales. Reward reactivity scale correlated mostly with items reflecting insightfulness. Earlier studies related Reward responsiveness from the BIS/BAS Scales (Carver & White, 1994) with problem-solving coping strategies (Hasking, 2007), suggesting the potential role of Reward responsiveness in goal-directed behaviour beyond the rest of the BAS scales which might underlie this association.

In recent study (Krupić, Gračanin, et al., 2016), the SR and Impulsivity were found to correlate with competitiveness, which corresponds to fast lifestyle strategy. However, our data did not reveal that. It would be expected that the SR and Impulsivity reflect lack of impulse control producing deficits in executive functions. However, analysing the correlational matrix between the BAS scales and Mini-K items, the SR and Impulsivity were found to correlate negatively only with item "*I avoid taking risks*". This is the only item that examines the risk-taking tendencies in the Mini-K, and in Croatian translation of the questionnaire it did not fit the model. Thus, the lack of negative correlations between the SR and Impulsivity might reflect the under-representation of items measuring risk-taking and immediate gratification tendencies in the Mini-K.

4.2. Friend social contact and support and experience in close relationship

Fast lifestyle individuals engage in antagonistic rather than mutualistic social strategies (Figueredo & Jacobs, 2010). This study shows that social contact and support (as one aspect of the slow lifestyle) correlates with Reward Interest and Reward reactivity, which is broadly consistent with findings of Krupić, Gračanin, et al. (2016). First, Reward Interest reflects proactivity and initiative, while complex goals and projects may assume many social contacts and cooperativeness. In addition, Reward reactivity manifests in expressing positive reaction following reward, which influences individual's social status and social acceptance (Bono & Ilies, 2006; Chen, Hsu, and Tsai, 2013; Lindsey, 2016).

Maintaining close relationships demands high level of self-regulation, as it assumes occasionally self-sacrificing and putting the others needs in the first place. In contrast, impulsive individuals, particularly psychopaths, may find hard to maintain friendships (Glenn, Kurzban, & Raine, 2011). Fast individuals typically minimize parental investment, and they are more interested in short-term relationships. Our data shows that the SR correlates negatively with experience in romantic relationship, which is congruent with the previous study exploring the evolutionary origin of the BAS (Krupić, Gračanin, et al., 2016).

4.3. Limitations

These findings should be interpreted with caution since they are obtained only by self-report methodology. Also, as there are different instruments of the BAS scales and LHT, the findings from the study should be generalised only to studies that used the same questionnaires. Finally, it would be desirable to replicate the findings by different methodology.

To conclude, our data indicate that Goal-Drive Persistence, Reward Interest and Reward reactivity reflect the BAS components that are prerequisite to plan and achieve long-term goals that characterise slow lifestyle. In particular, the executive functions related to slow lifestyle are the most related with the BAS scales, which may direct future studies further exploring evolutionary origin of multidimensional approach motivation and its relationship with executive functions.

References

- Aluja, A., & Blanch, A. (2011). Neuropsychological behavioral inhibition system (BIS) and behavioral approach system (BAS) assessment: A shortened Sensitivity to Punishment and Sensitivity to Reward Questionnaire version (SPSRQ–20). *Journal of Personality Assessment*, 93(6), 628-636. doi:10.1080/00223891.2011.608760
- Baumeister, R. F. (2016). Toward a general theory of motivation: Problems, challenges, opportunities, and the big picture. *Motivation and Emotion*, 40(1), 1-10. doi: 10.1007/s11031-015-9521-y
- Belsky, J., Steinberg, L., & Draper, P. (1991). Childhood experience, interpersonal development, and reproductive strategy: An evolutionary theory of socialization. *Child development*, 62(4), 647-670. doi: 10.2307/1131166
- Bono, J. E., & Ilies, R. (2006). Charisma, positive emotions and mood contagion. *The Leadership Quarterly*, 17(4), 317-334. doi:10.1016/j.leaqua.2006.04.008
- Buss, D. M. (2008). Human nature and individual differences: Evolution of human personality. In O. P. John, R. W. Robins and L. A. Pervin (Eds.), *Handbook of personality: Theory and research* (3rd ed.) (pp. 29–60). New York: Guilford Press.
- Carver, C. S., & White, T. L. (1994). Behavioral inhibition, behavioral activation, and affective responses to impending reward and punishment: The BIS/BAS Scales. *Journal of Personality and Social Psychology*, 67(2), 319-333. doi:10.1037/0022-3514.67.2.319
- Chen, C. C., Hsu, C. S., & Tsai, P. S. (2013). The process mechanisms linking recruiter positive moods and organizational attraction. *International Journal of Selection and Assessment*, 21(4), 376-387. doi:10.1111/ijsa.12047
- Cohen, J., Cohen, P., West, S. G., & Aiken, L. S. (2003). *Applied multiple regression/correlation analysis for the behavioural sciences* (3rd ed.). London: Erlbaum.
- Corr, P. J. (2008). Reinforcement sensitivity theory (RST): Introduction. In P. J. Corr (Ed), *The reinforcement sensitivity theory and personality* (pp. 1 - 43). Cambridge: Cambridge University Press. doi:10.1017/CBO9780511819384.002
- Corr, P. J. (2013). Approach and avoidance behavior: Multiple systems and their interactions. *Emotion Review*, 5(3), 286-291. doi:10.1177/1754073913477507

- Corr, P. J., DeYoung, C. G., & McNaughton, N. (2013). Motivation and personality: A neuropsychological perspective. *Social and Personality Psychology Compass*, 7(3), 158-175. doi:10.1111/spc3.12016
- Corr, P. J., & Cooper, A. (2016). The Reinforcement Sensitivity Theory of Personality Questionnaire (RST-PQ): Development and validation. *Psychological Assessment*, 28(11), 1427–1440.
- Del Giudice, M. (2014). Middle childhood: An evolutionary-developmental synthesis. *Child Development Perspectives*, 8, 193–200. doi:10.1111/cdep.12084
- Del Giudice, M., Gangestad, S. W., & Kaplan, H. S. (2015). Life history theory and evolutionary psychology. In D. M. Buss (Ed.), *The handbook of evolutionary psychology* (2nd ed.) (pp. 88-114). New York: Wiley.
- Depue, R. A. (2006). Interpersonal behavior and the structure of personality: Neurobehavioral foundation of agentic extraversion and affiliation. In C. Turhan (Ed.), *Biology of Personality and Individual Differences* (pp. 60 – 92). New York: Guilford Press.
- DeYoung, C. G., Quilty, L. C., & Peterson, J. B. (2007). Between facets and domains: 10 aspects of the Big Five. *Journal of Personality and Social Psychology*, 93(5), 880-896. doi:10.1037/0022-3514.93.5.880
- Ellis, B. J. (2004). Timing of pubertal maturation in girls: An integrated life history approach. *Psychological bulletin*, 130(6), 920-958. doi: 10.1037/0033-2909.130.6.920
- Ellis, B. J., Figueredo, A. J., Brumbach, B. H., & Schlomer, G. L. (2009). Effects of harsh versus unpredictable environments on the evolution and development of life history strategies. *Human Nature*, 20(2), 204-268. doi:10.1007/s12110-009-9059-3
- Figueredo, A. J. (2007). *The Arizona Life History Battery*. Retrived from: <http://www.u.arizona.edu/~ajf/alhb.html>
- Figueredo, A. J., Cuthbertson, A. M., Kauffman, I. A., Weil, E., & Gladden, P. R. (2012). The interplay of behavioral dispositions and cognitive abilities: Sociosexual orientation, emotional intelligence, executive functions and life history strategy. *Temas em Psicologia*, 20(1), 87-100.
- Figueredo, A. J., de Baca, T. C., & Woodley, M. A. (2013). The measurement of human life history strategy. *Personality and Individual Differences*, 55(3), 251-255. doi: 10.1016/j.paid.2012.04.033
- Figueredo, A. J., & Jacobs, W.J. (2010). Aggression, risk-taking, and alternative life history strategies: The behavioral ecology of social deviance. In M. Frias-Armenta,

- & V. Corral-Verdugo (Eds.), *Biopsychosocial Perspectives on Interpersonal Violence* (pp. 3-27). Hauppauge, NY: Nova Science Publishers.
- Figueredo, A. J., Vásquez, G., Brumbach, B. H., Schneider, S. M. R., Sefcek, J. A., Tal, I. R., Hill, D., Wenner, C. J., & Jacobs, W. J. (2006). Consilience and life history theory: From genes to brain to reproductive strategy. *Developmental Review, 26*(2), 243 – 275. doi: 10.1016/j.dr.2006.02.002
- Figueredo, A. J., Vásquez, G., Brumbach, B. H., & Schneider, S. M. (2004). The heritability of life history strategy: The k-factor, covitality, and personality. *Social biology, 51*(3-4), 121-143. doi:10.1080/19485565.2004.9989090
- Figueredo, A. J., Vásquez, G., Brumbach, B. H., Sefcek, J. A., Kirsner, B. R., & Jacobs, W. J. (2005). The K-factor: Individual differences in life history strategy. *Personality and Individual Differences, 39*(8), 1349-1360. doi:10.1016/j.paid.2005.06.009
- Figueredo, A. J., Wolf, P. S. A., Olderbak, S. G., Gladden, P. R., Fernandes, H. B. F., Wenner, C., ... & Hohman, Z. J. (2014). The psychometric assessment of human life history strategy: A meta-analytic construct validation. *Evolutionary Behavioral Sciences, 8*(3), 148-185. doi:10.1037/h0099837
- Geary, D. C. (2002). Sexual selection and human life history. *Advances in Child Development and Behavior, 30*, 41–101.
- Glenn, A. L., Kurzban, R., & Raine, A. (2011). Evolutionary theory and psychopathy. *Aggression and violent behavior, 16*(5), 371-380. doi:10.1016/j.avb.2011.03.009
- Gray, J. A., & McNaughton, N. (2000). *The neuropsychology of anxiety: An enquiry into the functions of the septo-hippocampal system (2nd ed)*. New York: Oxford University Press.
- Hagen, E. H., & Hammerstein, P. (2005). Evolutionary biology and the strategic view of ontogeny: Genetic strategies provide robustness and flexibility in the life course. *Research in Human Development, 2*(1-2), 87 – 101. doi:10.1080/15427609.2005.9683346
- Hasking, P. A. (2007). Reinforcement sensitivity, coping, and delinquent behaviour in adolescents. *Journal of Adolescence, 30*(5), 739-749. doi:10.1016/j.adolescence.2006.11.006
- Hu, L. T., & Bentler, P. M. (1999). Cut off criteria for fit indexes in covariance structure analysis: Conventional criteria versus new alternatives. *Structural Equation Modeling: A Multidisciplinary Journal, 6*(1), 1-55. doi:10.1080/10705519909540118

- Jonason, P. K., Koenig, B. L., & Tost, J. (2010). Living a fast life. *Human Nature*, *21*(4), 428-442. doi: 10.1007/s12110-010-9102-4
- Kaplan, H.S., & Gangestad, S.W. (2005). Life history theory and evolutionary psychology. In D. M. Buss (Ed.), *The handbook of evolutionary psychology* (pp. 68–96). New York: Wiley. doi:10.1002/evan.1360020303
- Kenrick, D. T., & Shiota, M. N. (2008). Approach and avoidance. In A. J. Elliot (Ed.), *Handbook of approach and avoidance motivation*, (pp. 273-288). New York: Psychology Press.
- Kruglanski, A. W., Chernikova, M., & Kopetz, C. (2015). Motivation science. In R. Scott, & S. Kosslyn (Eds.), *Emerging trends in the social and behavioral sciences: An Interdisciplinary, Searchable, and Linkable Resource* (pp. 1-16). New York: Wiley.
- Krupić, D., Corr, P. J., Ručević, S., Križanić, V., & Gračanin, A. (2016). Five reinforcement sensitivity theory (RST) of personality questionnaires: Comparison, validity and generalization. *Personality and Individual Differences*, *97*, 19-24. doi:10.1016/j.paid.2016.03.012
- Krupić, D., Gračanin, A. & Corr, P. J. (2016). The evolution of the behavioural approach system (BAS): Cooperative and competitive resource acquisition strategies. *Personality and Individual Differences*, *94*, 223–227. doi:10.1016/j.paid.2016.01.044
- Kuzawa, C. W., & Bragg, J. M. (2012). Plasticity in human life history strategy. *Current Anthropology*, *53*, S369–S382. doi:10.1086/667410
- Lindsey, E. W. (2016). Mutual positive emotion with peers, emotion knowledge, and preschoolers' peer acceptance. *Social Development*, *26*(2), 349-366. doi:10.1111/sode.12201
- MacDonald, K. (1995). Evolution, the five-factor model, and levels of personality. *Journal of Personality*, *63*(3), 525–567. doi:10.1111/j.1467-6494.1995.tb00505.x
- MacDonald, K. B. (2012). Temperament and evolution. In M. Zentner, & R. L. Shiner (Eds.), *Handbook of temperament* (pp. 273– 296). New York: Guilford Press.
- Penke, L., Denissen, J. J., & Miller, G. F. (2007). The evolutionary genetics of personality. *European Journal of Personality*, *21*(5), 549-587. doi:10.1002/per.629

- Quinlan, R. J. (2007). Human parental effort and environmental risk. *Proceedings of the Royal Society of London B: Biological Sciences*, 274(1606), 121-125.
doi:10.1098/rspb.2006.3690
- Réale, D., Garant, D., Humphries, M. M., Bergeron, P., Careau, V., & Montiglio, P. O. (2010). Personality and the emergence of the pace-of-life syndrome concept at the population level. *Philosophical Transactions of the Royal Society B*, 365, 4051–4063. doi:10.1098/rstb.2010.0208
- Sherman, R., Figueredo, A. J., & Funder, D. C. (2013). The behavioral correlates of overall and distinctive life history strategy. *Journal of Personality and Social Psychology*, 105(5), 873–88. doi:10.1037/a0033772
- Sih, A., & Del Giudice, M. (2012). Linking behavioural syndromes and cognition: A behavioural ecology perspective. *Philosophical Transactions of the Royal Society of London B*, 367(1603), 2762-2772. doi:10.1098/rstb.2012.0216
- Simpson, J. A., Griskevicius, V., & Kim, J. S. (2011). Evolution, life history theory, and personality. In: L. M. Horowitz, and S. Strack (Eds.), *Handbook of interpersonal psychology: Theory, research, assessment, and therapeutic interventions* (pp. 75-89). Hoboken: John Wiley & Sons Inc.
- Wenner, C. J., Bianchi, J., Figueredo, A. J., Rushton, J. P., & Jacobs, W. J. (2013). Life history theory and social deviance: The mediating role of executive function. *Intelligence*, 41(2), 102-113. doi:10.1016/j.intell.2012.11.004
- Wolf, M., van Doorn, G. S., Leimar, O., & Weissing, F. J. (2007). Life-history trade-offs favour the evolution of animal personalities. *Nature*, 447(7144), 581–585.
doi:10.1038/nature05835